

Instruction Manual

Model 3116-64T42 Translator

February 2025, Rev. 0

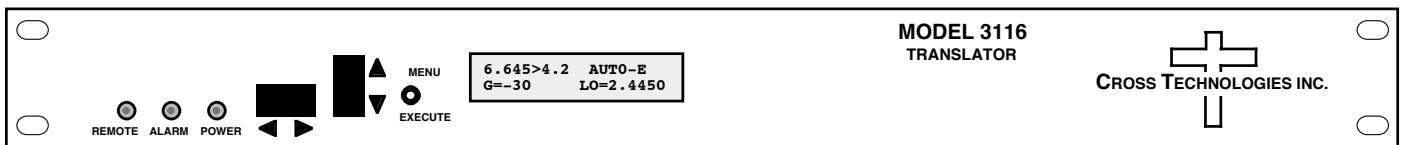

Data, drawings, and other material contained herein are proprietary to Cross Technologies, Inc., but may be reproduced or duplicated without the prior permission of Cross Technologies, Inc. for purposes of operating the equipment.

When ordering parts from Cross Technologies, Inc., be sure to include the equipment model number, equipment serial number, and a description of the part.



6170 Shiloh Road
Alpharetta, Georgia 30005

(770) 886-8005
FAX (770) 886-7964
Toll Free 888-900-5588

WEB www.crosstechnologies.com
E-MAIL info@crosstechnologies.com

INSTRUCTION MANUAL
MODEL 3116-64T42 Translator

<u>TABLE OF CONTENTS</u>	<u>PAGE</u>
Warranty	2
1.0 General	3
1.1 Equipment Description	3
1.2 Technical Characteristics	4
2.0 Installation	8
2.1 Mechanical	8
2.2 Rear Inputs and Outputs	9
2.3 Front Panel Indicators	10
2.4 Operation	11
2.5 Environmental Use Information	15

WARRANTY - The following warranty applies to all Cross Technologies, Inc. products.

All Cross Technologies, Inc. products are warranted against defective materials and workmanship for a period of one year after shipment to customer. Cross Technologies, Inc.'s obligation under this warranty is limited to repairing or, at Cross Technologies, Inc.'s option, replacing parts, subassemblies, or entire assemblies. Cross Technologies, Inc. shall not be liable for any special, indirect, or consequential damages. This warranty does not cover parts or equipment which have been subject to misuse, negligence, or accident by the customer during use. All shipping costs for warranty repairs will be prepaid by the customer. There are not other warranties, express or implied, except as stated herein.



6170 Shiloh Road
Alpharetta, Georgia 30005

(770) 886-8005
FAX (770) 886-7964
Toll Free 888-900-5588

WEB www.crosstechnologies.com
E-MAIL info@crosstechnologies.com

MODEL 3116-64T42 Translator

1.0 General

1.1 Equipment Description

The 3116-64T42 Translator converts 5.845-6.425 GHz to 3.62-4.20 GHz with a 2.225 GHz local oscillator. Front panel LEDs provide indication of Remote operation, PLL Alarm, and DC Power. The RF to RF gain is -20 to -50 dB, adjustable in 0.5 ± 0.5 dB steps. Connectors are N-type female for RF out, RF in and BNC female for external 10 MHz in and 10 MHz out. In AUTO, the 10 MHz reference stays in external if the external level is +3 dBm, ± 3 dB. Gain and internal 10 MHz frequency are controlled by the front panel switches or the M&C connector (Ethernet optional). It is powered by a 100-240 $\pm 10\%$ VAC power supply and is in a 1.75" X 19" X 14" rack mount chassis.

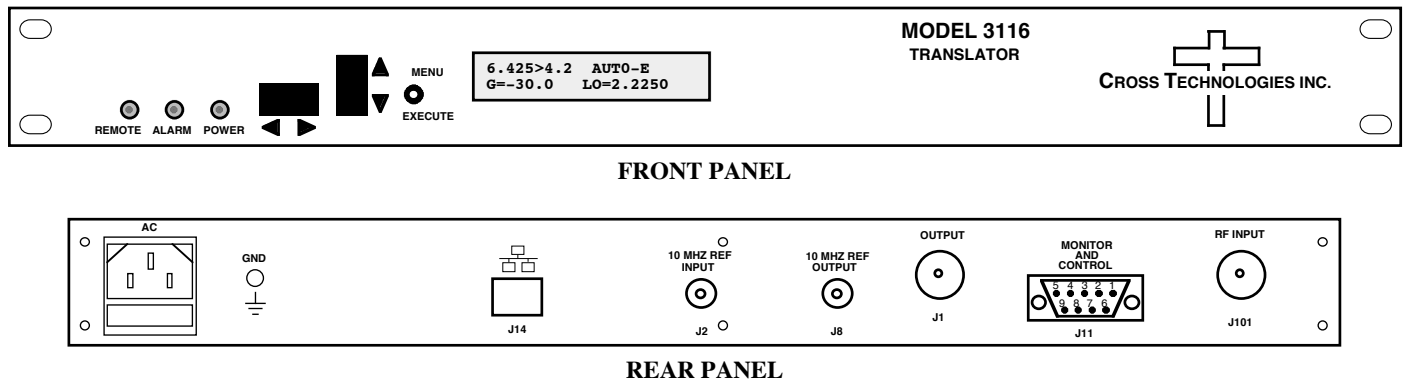

FIGURE 1.1 Front and Rear Panels

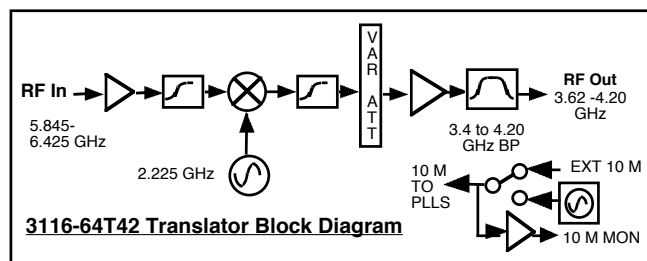

FIGURE 1.2 Block Diagram

1.2 Technical Characteristics

TABLE 1.0 3116-64T42 Translator Specifications**					
Input Characteristics					
Impedance/Return Loss	50Ω /12 dB, 14 dB typical				
Frequency (GHz)	5.845 to 6.425 GHz				
Input Level Range	-30 to -10 dBm				
Input 1dB Compression	0 dBm, Gmax				
Output Characteristics					
Impedance/Return Loss	50Ω / 12 dB, 14 dB typical				
Frequency (GHz)	3.62 to 4.20 GHz				
Output Level Range	-60 to -30 dBm				
Output 1 dB Compression	-20 dBm, Gmax				
Channel Characteristics					
Gain, Maximum	-20 ±3 dB, at Fc				
Gain Range	-20 to -50 dB; 0.5 ±0.5 dB steps				
In to Out Isolation, Minimum	> 40 dBC, > 50 typical				
Spurious, Inband	> 40 dBC				
Spurious, Out of Band	> 20 dBC, Fc ± 1 GHz, > 40 dBC, Fc ±2 GHz				
Spurious LO	> 20 dBC at the output; < -40 LO out the input;				
2 tone @ -35 dBm out each	> 50 dBC, Gain = -20				
Frequency Response	± 1.5 dB, 3.62 - 4.20 GHz out; ± 0.5 dB, 40 MHz BW				
Frequency Sense	Non-Inverting				
LO Characteristics					
LO Frequency	2.225 GHz				
Frequency Accuracy	± 0.01 ppm maximum over temp internal reference; external reference input				
10 MHz In/Out Level	+3 dBm, ±3 dB				
Phase Noise @ Frequency	100	1k	10k	100k	1M
dBC/Hz	-70	-80	-85	-100	-110
Controls, Indicators					
Gain, 10M Frequency	Gain & internal 10 MHz frequency, Front Panel Switches or M&C connector (Ethernet Optional).				
PLL Alarm	Red LED; External Contact Closure				
Power	Green LED				
Remote	RS232C, 9600 baud (Ethernet Optional)				
Other					
RF In/RF Out Connectors	N-type (female) 50Ω				
10 MHz Connectors	BNC (female), 75Ω; Works with 50Ω				
Monitor/Control Connector	RS232C, DB9, Female; Optional Ethernet, RJ45, Female				
Size	19 inch, 1RU Standard Chassis 1.75" high x 14.0" deep				
Power	100-240 ±10% VAC, 47- 63 Hz, 30 watts maximum				
**+10°C to +40°C Operating; -30°C to +60°C Non-Operating; 95% relative humidity, non-condensing; Specifications subject to change without notice. © Cross Technologies, Inc. 2017					

Continued on page 5...

Continued from page 4...

Available Options	
-W8	Ethernet; with Web Browser
-W18	Ethernet; with Web Browser & SNMP
-W28	Ethernet; with Telnet
-W828	Ethernet; with Web Browser, SNMP, and Telnet
Connectors/Impedance	
-NN	50Ω N-type (RF)
**+10°C to +40°C Operating; -30°C to +60°C Non-Operating; 95% relative humidity, non-condensing; Specifications subject to change without notice. © Cross Technologies, Inc. 2017	

1.3 Monitor & Control Interface

The following tables summarize the commands and status queries applicable to the 3116-64T42 Translator.

* **PLEASE NOTE:** The two character {aa} prefix, shown in the table below, is present ONLY when RS485 is selected.

Table 2.0 Model 3116-64T42 M&C Commands

Table 2.0: Model 3116-64T42 M&C Commands		
Command	Syntax	Description
Set Gain	{aaCGxxxx}	where:
		xxxx = 4 characters
		Range: -200 to -500 in 0.5 ±0.5 dB steps (e.g., -220 = -22.0 dB)
Set Mute	{aaCMx}	where:
		x = 1 to mute the output
		x = 0 to unmute the output
Set External Reference	{aaCEx}	where:
		x = 0 to select internal reference
		x = 1 to select external reference
		x = 2 for auto-select
Set Reference Offset	{aaCOxxxxx}	where:
		-2000 ≤ xxxxx ≤ +2000

continued on page 7...

Table 2.0 Model 3116-64T42 M&C Commands (continued)

Table 2.0: Model 3116-64T42 M&C Commands (continued)		
Command	Syntax	Description
Gain	{aaSG}	Returns {aaSGxxxx} where:
		xxxx = 4 characters
		Range: (-200 to -500 in 0.5 ±0.5 dB steps)
10 MHz reference	{aaSE}	Returns {aaSEx} where:
		x = 0 if Internal 10 MHz reference is selected
		x = 1 if External 10 MHz reference is selected
		x = 2 if in auto-select mode
Unit Status	{aaSA}	Returns {aaSAx} where:
		x = 0 if no summary alarm, x = 1 if summary alarm
Reference Offset	{aaSO}	Returns {aaSOxxxxx} where:
		xxxxx is a signed number representing the ref. offset value
Model and firmware revision	{aaSV}	Returns {aaSVxxxxxxxxyyyy} where:
		xxxxxxxx = unit model number
		yyyy = unit firmware rev.
10 MHz reference status	{aaSB}	Returns {aaSBx} where:
		x = 0 if the reference is on internal
		x = 1 if the reference is on external

2.0 Installation

2.1 Mechanical - The 3116-64T42 Multi-Band Block Translator consists of a controller board and RF plate assembly. A switching ± 12 , $+24$, $+5$ VDC power supply provides power for the assemblies. The 3116-64T42 can be secured to a rack using the 4 holes on the front panel. Figure 2.0 shows how the 3116-64T42 is assembled.

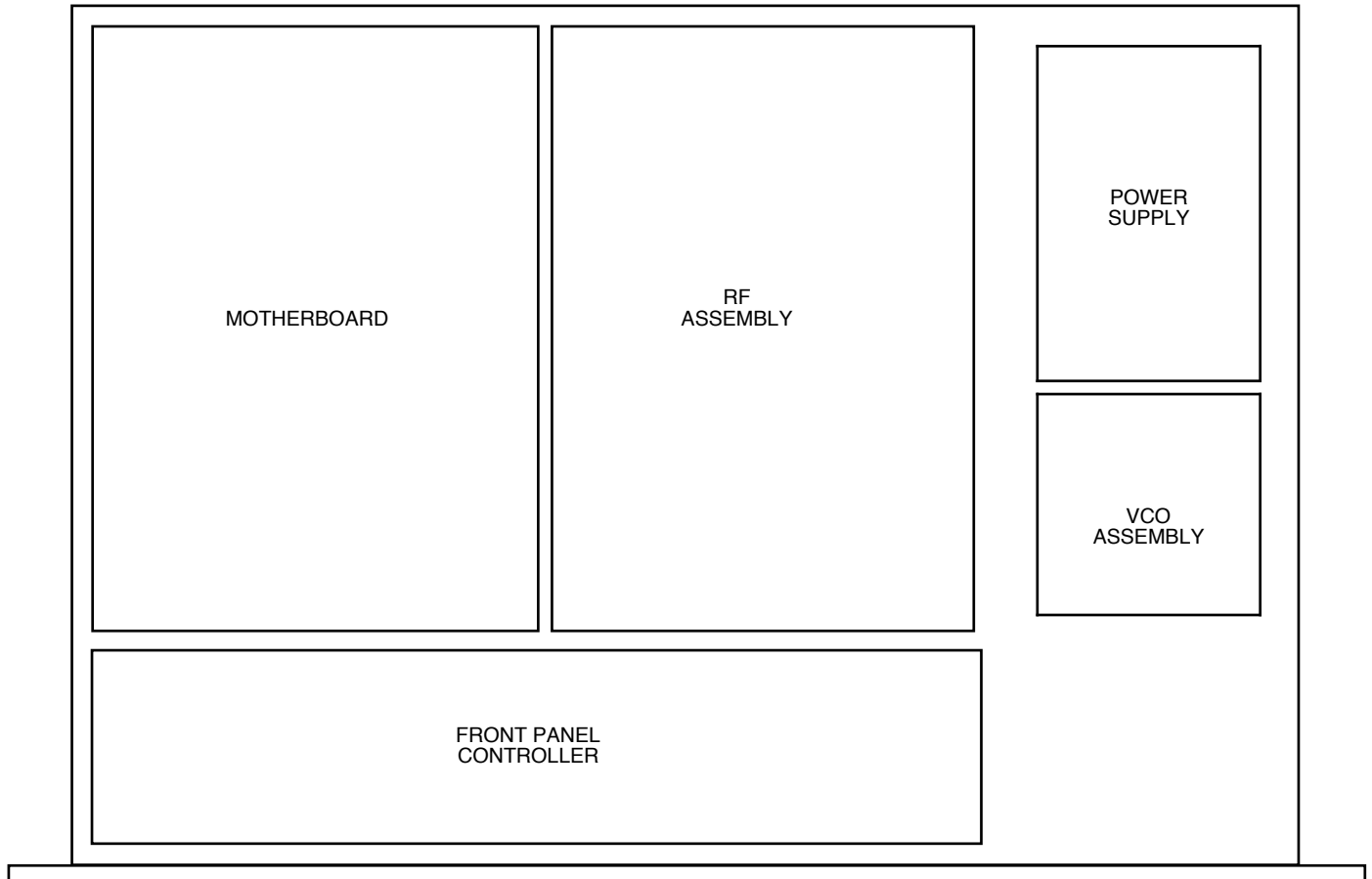

FIGURE 2.0 3116-64T42 Mechanical Assembly

2.2 Rear Panel Input / Output Signals - Figure 2.2 shows the input and output connectors on the rear panel.

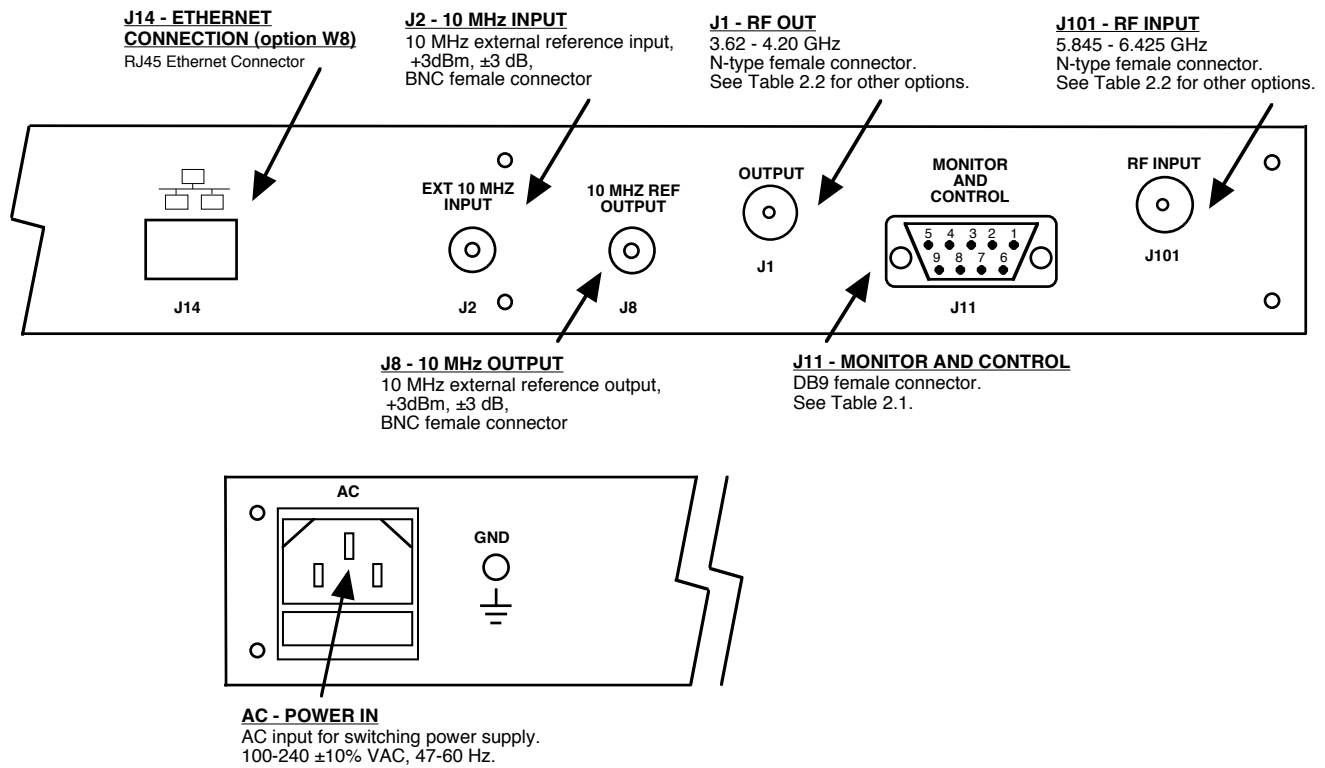

FIGURE 2.2 3116-64T42 Rear Panel Inputs and Outputs

TABLE 2.1 J11 Pinouts*	
Pin	Function
1	Rx-
2	Rx+ (RS-232C)
3	Tx+ (RS-232C)
4	Tx-
5	GND
6	Alarm Relay: Common
7	Alarm Relay: Normally Open
8	Not Used
9	Alarm Relay: Normally Closed

*Interface: DB-9 Female
 Protocol: RS485, RS422, or RS232C (selectable),
 9600 baud rate, no parity, 8 data bits, 1 start bit, 1 stop bit

2.3 Front Panel Controls and Indicators -

Figure 2.3 shows the front panel controls and indicators.

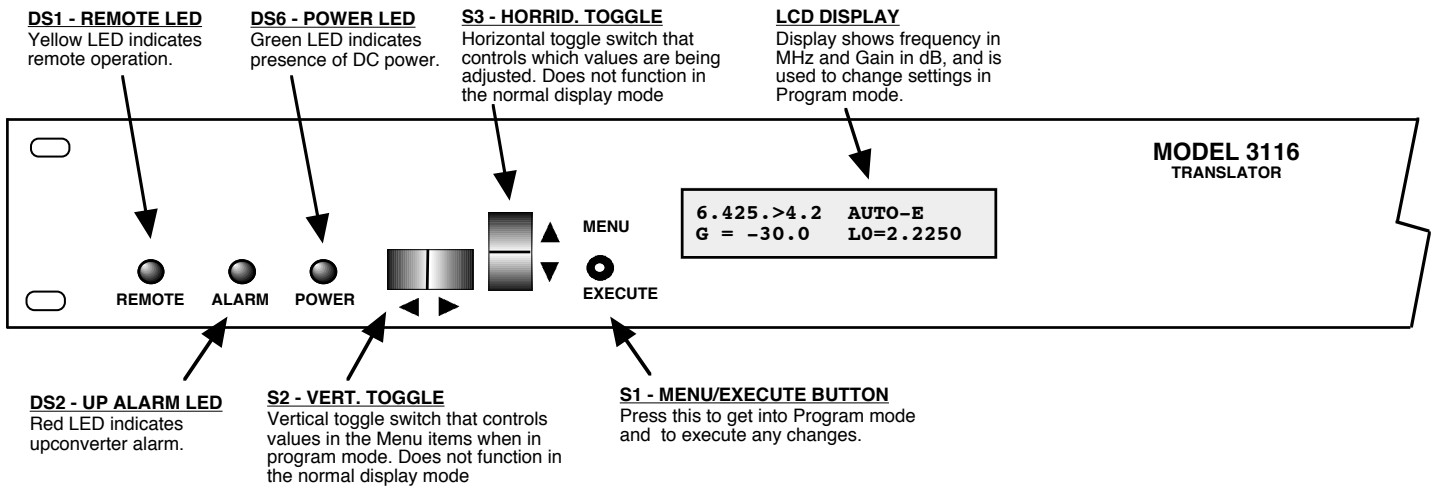

FIGURE 2.3 3116-64T42 Front Panel Controls and Indicators

2.4 Installation/Operation

Installing and Operating the 3116-64T42 Translator:

1. Connect a -30 dBm to -10 dBm signal to RF-BAND INPUT (J2) Figure 2.2.
2. Connect the RF OUTPUT (J1), to the external equipment.
3. Connect 100-240 \pm 10% VAC, 47 - 63 Hz to AC connector to the front panel.
4. Be sure DS6 (green, DC Power) is on and DS2 (red, Alarm) is off (Figure 2.3).
5. Set the gain so that the output level is always within the range of -20 to -50 dBm (See Table 2.0).
6. Select either INT (for internal 10 MHz ref), or EXT (for external 10 MHz, +3 to +3 dBm reference that is inserted at J3).
7. AC Fuse - The fuse is a 1A/250V 1.25" x .25" (slow blow) and is inserted in the fuse F1 position.

NOTE: If a fuse continues to open, the power supply is most likely defective.

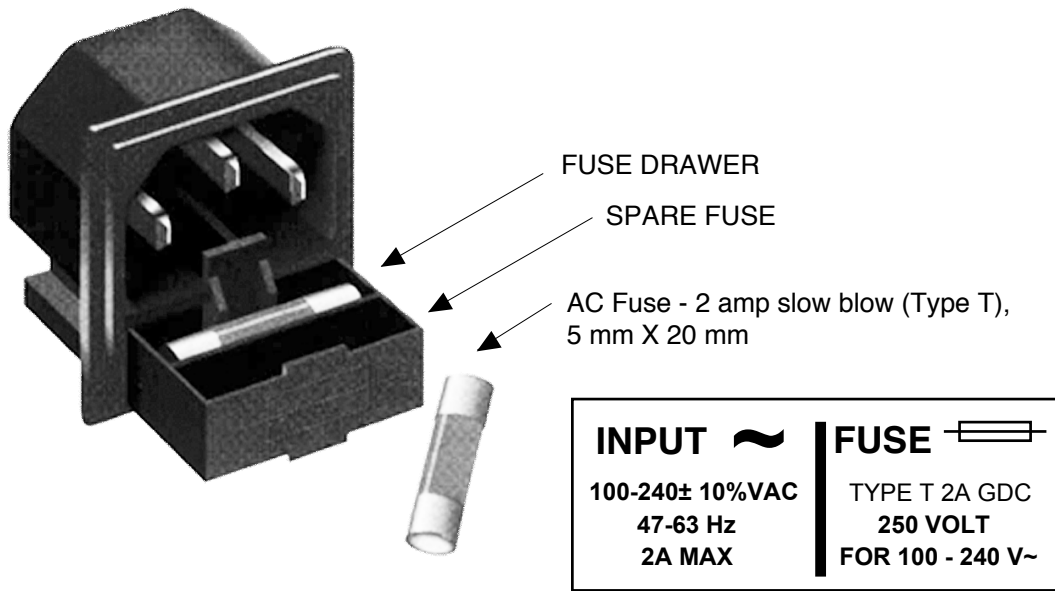

FIGURE 2.4 Fuse Location and Spare Fuse

2.5 Menu Settings

2.5.1 Functions - This section describes operation of the front panel controls. There are three operator switches, the LCD display and alarm indicator LEDs. All functions for the equipment are controlled by these components. The functions are (see Figure 2.3):

Power Up

Normal Display

- Menu 1** Gain in dB (-20 to -50 dB in 1±1 dB steps)
- Menu 2** Mute TX Signal
- Menu 3** Select 10 MHz Reference (Internal, External, Auto)
- Menu 4** Set Reference Frequency Offset
- Menu 5** Set Remote on/off
- Menu 6** Set Secondary Communications Interface
- Save Menu** When “R” is selected in any of the above menus or when operator reaches the end.

Alarm indications appear on the LEDs (See figure 2.3).

All program changes must start with the operation of the Menu/Execute switch and must also end with the operation of the Menu/Execute switch verified by the “Save Settings?” Menu. If this sequence is not followed, none of the changes will take effect. If programming is initiated and no operator action takes place for approximately 12 seconds, (before the final press of the Menu/Execute switch), the display will revert to its previous status and you will need to start over.

2.6 Power On Settings

NOTE: The last status of a unit is retained even when power is removed.

When power is restored, the unit will return to its previous settings.

When power is first applied, the LCD display goes through three steps.

1. The LCD goes black to show all segments are functioning.
2. The software version will be displayed.



REV 1.00

3. The present band, gain, 10 MHz reference and output frequency range are shown.

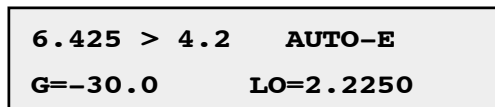

6.425 > 4.2 AUTO-E
G=-30.0 LO=2.2250

The unit is now operational and ready for any changes the operator may desire.

2.6.1 Control Switches

1. Menu/Execute - Any change to the programming of the unit must be initiated by pressing the Menu/Execute switch and completed by pressing the Menu/Execute switch.
2. Horizontal Switch - This switch is mounted so its movement is horizontal and moves the cursor left or right.
3. Vertical Switch - This switch is mounted so its movement is vertical and has two functions:
 - A. During frequency, gain changes, the vertical movement will raise or lower the number in the direction of the arrows.
 - B. For other functions such as Mute on/off, the vertical switch will alternately turn the function on or off regardless of the direction operated.

2.6.2 Gain Changes

When you get to this menu note that the gain changes will be made as you make them but if you do not wish to save the changes you have made, scroll to “R” and push the menu/Execute switch and select “NO” in the

“SAVE SETTINGS?” window or **do not press the Menu/Execute switch**; simply do nothing for approximately 30 seconds and the system will return to the normal operating mode.

NOTE: CHANGES TAKE PLACE ON LEVEL AND GAIN IMMEDIATELY BUT DO NOT GET SAVED UNTIL YOU GO TO THE SAVE MENU AND INDICATE YOU WANT TO SAVE THE CHANGES.

Press the Up/Down switch to change the level in 0.5 dB steps and then push the Menu/Execute switch to get to the Gain setting:

GAIN = -20

Press the Up/Down switch to change the gain in 1 or 10 dB steps:

GAIN = -30.0

By using the horizontal rocker switch the cursor can be moved left or right. Pressing the Up/Down switch down will toggle the display digit selected until you have the desired gain.

When the display indicates the value desired you can push the Menu/Execute switch to the next item OR you can scroll to “R”, push the Menu/Execute switch to get to:

SAVE SETTINGS? Y N

Selecting **Y** will save the new settings. Selecting **N** will revert to the previous settings. Pushing the Menu/Execute switch then takes you to:

2.6.3 Alarm Indications

An alarm condition will occur if the local oscillator phase lock loop (PLL) comes out of lock. The Mute LED will light if you select to mute the Tx Signal and the Remote LED will light when you select the Remote mode.

ON POWER UP

3116-64T42
4.00

NORMAL DISPLAY

6.425 > 4.2 AUTO-E
G= -30.0 LO=2.4450

PUSH BUTTON

PUSHING MENU/EXECUTE SEQUENCE

G = -20.0

R

SCROLL <>

SCROLL ⤴

PUSH BUTTON

MUTE OFF

R

SCROLL <>

SCROLL ⤴

PUSH BUTTON

REF MODE = INT

R

SCROLL <>

SCROLL ⤴

PUSH BUTTON

REF OS = +0000

R

SCROLL <>

SCROLL ⤴

PUSH BUTTON

REMOTE = ON

R

SCROLL <>

SCROLL ⤴

PUSH BUTTON

COMM INTERFACE
RS232

R

SCROLL <>

SCROLL ⤴

PUSH BUTTON

SAVE SETTINGS? Y N

SCROLL <>

PUSH BUTTON

FIGURE 2.5 Menu Display and Sequence

3.0 Environmental Use Information

- A. **Rack-Mounting** - To mount this equipment in a rack, please refer to the installation instructions located in the user manual furnished by the manufacturer of your equipment rack.
- B. **Mechanical Loading** - Mounting of equipment in a rack should be such that a hazardous condition does not exist due to uneven weight distribution.
- C. **Elevated Operating Ambient Temperature** - If installed in a closed or multiunit rack assembly, the operating ambient temperature of the rack may be greater than room ambient temperature. Therefore, consideration should be given to Tmra (Maximum Recommended Ambient Temperature).
- D. **Reduced Air Flow** - Installation of the equipment in a rack should be such that the amount of air flow required for safe operation of the equipment is not compromised. Additional space between units may be required.
- E. **Circuit Overloading** - Consideration should be given to the connection of the equipment to the supply circuit and the effect that overloading of circuits could have on over current protection and supply wiring. Appropriate consideration of equipment name plate rating should be used when addressing this concern.
- F. **Reliable Earthing** - Reliable earthing of rack-mounted equipment should be maintained. Particular attention should be given to supply connections other than direct connection to the Branch (use of power strips).
- G. **Top Cover** - There are no serviceable parts inside the product so, the Top Cover should not be removed. If the Top Cover is removed the ground strap and associated screw **MUST BE REINSTALLED** prior to Top Cover screw replacement. **FAILURE TO DO** this may cause **INGRESS** and/or **EGRESS** emission problems.



6170 Shiloh Road
Alpharetta, Georgia 30005

(770) 886-8005
FAX (770) 886-7964
Toll Free 888-900-5588

WEB: www.crosstechnologies.com
E-MAIL: info@crosstechnologies.com

Printed in USA