

Instruction Manual

Model 2116-14T17 Block Translator

October 2015, Rev. B

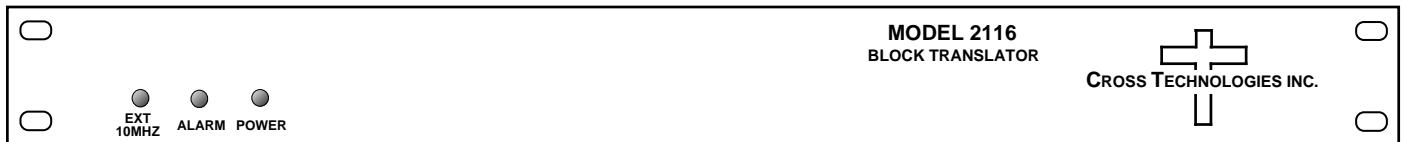

Data, drawings, and other material contained herein are proprietary to Cross Technologies, Inc., but may be reproduced or duplicated without the prior permission of Cross Technologies, Inc. for purposes of operating the equipment.

When ordering parts from Cross Technologies, Inc., be sure to include the equipment model number, equipment serial number, and a description of the part.



6170 Shiloh Road
Alpharetta, Georgia 30005

(770) 886-8005
FAX (770) 886-7964
Toll Free 888-900-5588

WEB www.crosstechnologies.com
E-MAIL info@crosstechnologies.com

INSTRUCTION MANUAL

MODEL 2116-14T17 Block Translator

<u>TABLE OF CONTENTS</u>	<u>PAGE</u>
Warranty	2
1.0 General	3
1.1 Equipment Description	3
1.2 Technical Characteristics	4
1.3 Environmental Use Information	5
2.0 Installation	6
2.1 Mechanical	6
2.2 Rear Inputs and Outputs	7
2.3 Front Panel Indicators	7
2.4 Operation	8

WARRANTY - The following warranty applies to all Cross Technologies, Inc. products.

All Cross Technologies, Inc. products are warranted against defective materials and workmanship for a period of one year after shipment to customer. Cross Technologies, Inc.'s obligation under this warranty is limited to repairing or, at Cross Technologies, Inc.'s option, replacing parts, subassemblies, or entire assemblies. Cross Technologies, Inc. shall not be liable for any special, indirect, or consequential damages. This warranty does not cover parts or equipment which have been subject to misuse, negligence, or accident by the customer during use. All shipping costs for warranty repairs will be prepaid by the customer. There are not other warranties, express or implied, except as stated herein.



6170 Shiloh Road
Alpharetta, Georgia 30005

(770) 886-8005
FAX (770) 886-7964
Toll Free 888-900-5588

WEB www.crosstechnologies.com
E-MAIL info@crosstechnologies.com

MODEL 2116-14T17 Block Translator

1.0 General

1.1 Equipment Description

The 2116-14T17 Block Translator converts 14.0 - 14.5 GHz to 11.2 - 11.7 GHz with a local oscillator at 2.8 GHz. Front panel LEDs provide indication of DC Power, External 10 MHz, and PLL Alarm. The gain is -30 dB to Output #1 and -50 to Output #2. Connectors are SMA female for RF and BNC female for the external reference input and reference output. A three-way switch controls which 10 MHz reference is being used. In the INT position, the internal reference is used, in the EXT position, the external reference is used, and in the AUTO position, the internal reference is used unless a 3 dBm \pm 3 dB, 10 MHz reference signal is connected to the external reference input. The 2116 is powered by a 100-240 \pm 10% VAC power supply, and mounted in a 1 3/4" X 19" X 14" rack mount chassis.

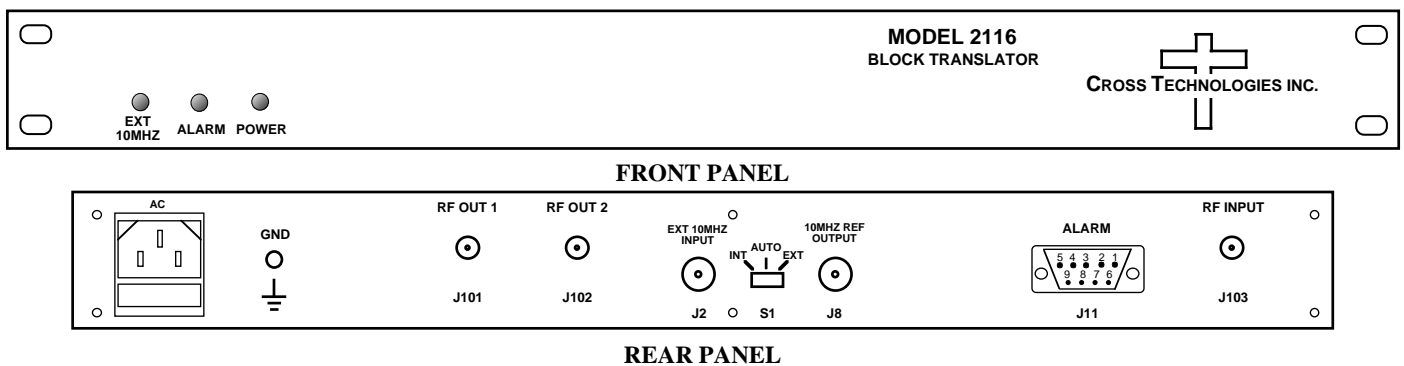

FIGURE 1.1 Front and Rear Panels

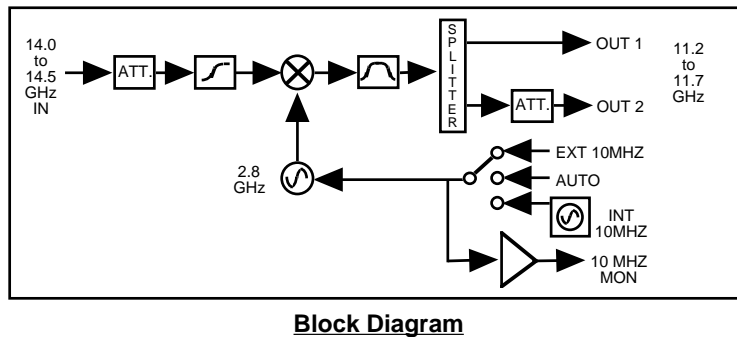

FIGURE 1.2 Block Diagram

1.2 Technical Characteristics

TABLE 1.0 2116-14T17 Block Translator Specifications*

Input Characteristics

Impedance/Return Loss	50 Ω /15 dB, typ., 14dB min. (See TABLE 2.2 for connector options)
Frequency	14.0 to 14.5 GHz
Noise Figure, max.	20 dB, max gain
Input Level	-30 to 0 dBm
Input 1dB Compression	+10 dBm

Output Characteristics

Impedance/Return Loss	50 Ω /15 dB, typ., 14dB min. (See TABLE 2.2 for connector options)
Frequency	11.2 to 11.7 GHz
Level Range (Output #1)	-60 to -30 dBm
Level Range (Output #2)	-80 to -50 dBm

Channel Characteristics

Gain (Output #1)	-30 dB \pm 2 dB
Gain (Output #2)	-50 dB \pm 2 dB
Input/Output Isolation	60 dB, min.
Intermodulation	<-50 dBC for two carriers each at -10 dBm
Spurious	< -45 dBC
Frequency Response	\pm 1.5 dB, 11.7-12.2 GHz out; \pm 0.5 dB, 40 MHz BW
Frequency Sense	Non-inverting

LO Characteristics

LO Frequency	2.3 GHz
Frequency Accuracy	\pm 0.01 ppm max over temp internal reference
10 MHz In/Out Level	+3 dBm \pm 3 dB

Phase Noise @ Freq	10Hz	1kHz	10kHz	100kHz	1MHz
dBc/Hz	-70	-80	-90	-100	-110

Controls, Indicators

Power	Green LED
PLL Alarm	Red LED, External contact closure
Ext 10 MHz	Yellow LED, Indicates Ext 10 MHz ref is selected (rear panel switch)
10 MHz Reference	3-way Switch (selects INTERNAL, EXTERNAL, or AUTO mode)

Other

RF Connectors	SMA (female) (see TABLE 2.2 for other options)
10 MHz Connectors	BNC (female) 50 Ω /75 Ω
Alarm Connector	DB9 (female) - NO or NC contact closure on Alarm
Size	19 inch, 1RU standard chassis 1.75"high X 14.0" deep
Power	100-240 \pm 10 VAC, 47-63 Hz, 45 watts max

Options

Connector Options	See TABLE 2.2
-------------------	---------------

*+10°C to +40°C; Specifications subject to change without notice.

1.3 Environmental Use Information

- A. **Rack-Mounting** - To mount this equipment in a rack, please refer to the installation instructions located in the user manual furnished by the manufacturer of your equipment rack.
- B. **Mechanical loading** - Mounting of equipment in a rack should be such that a hazardous condition does not exist due to uneven weight distribution.
- C. **Elevated operating ambient temperature** - If installed in a closed or multi-unit rack assembly, the operating ambient temperature of the rack may be greater than room ambient temperature. Therefore, consideration should be given to Tmra.
- D. **Reduced air flow** - Installation of the equipment in a rack should be such that the amount of air flow required for safe operation of the equipment is not compromised. Additional space between units may be required.
- E. **Circuit Overloading** - Consideration should be given to the connection of the equipment to the supply circuit and the effect that overloading of circuits could have on over current protection and supply wiring. Appropriate consideration of equipment name plate rating should be used, when addressing this concern.
- F. **Reliable Earthing** - Reliable earthing of rack-mounted equipment should be maintained. Particular attention should be given to supply connections other than direct connection to the Branch (use of power strips).
- G. **Top Cover** - There are no serviceable parts inside the product so, the Top Cover should not be removed. If the Top Cover is removed the ground strap and associated screw **MUST BE REINSTALLED** prior to Top Cover screw replacement. **FAILURE TO DO** this may cause **INGRESS** and/or **EGRESS** emission problems.

2.0 Installation

2.1 Mechanical

The 2116-14T17 consists of one RF PCB housed in a 1 RU (1 3/4 inch high) by 14 inch deep chassis. A switching, ± 12 , +24, +5 VDC power supply provides power for the assemblies. The 2116-14T17 can be secured to a rack using the 4 holes on the front panel. Figure 2.0 shows how the 2116-14T17 is assembled.

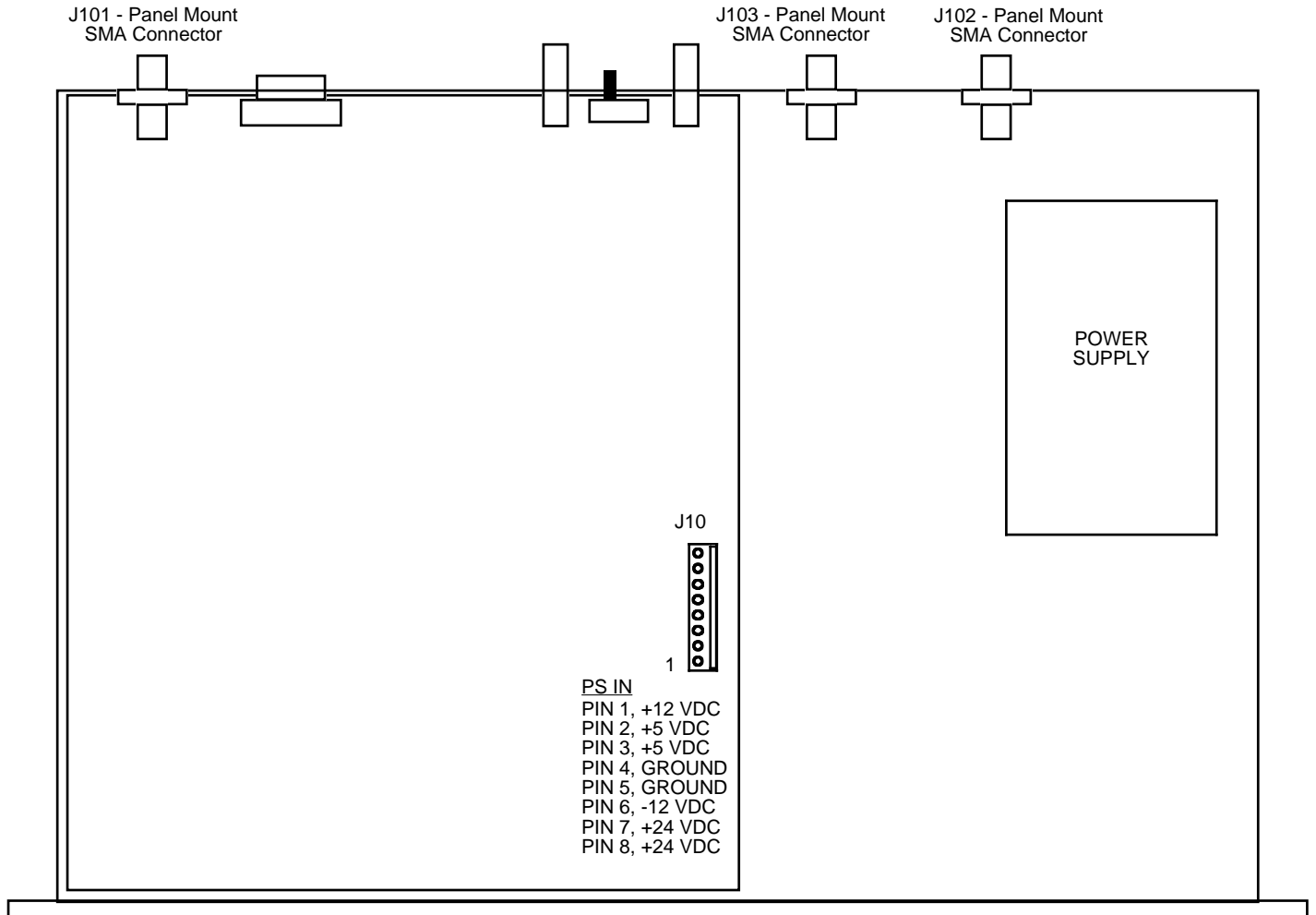

FIGURE 2.0 2116-14T17 Mechanical Assembly

2.2 Rear Panel Input/Output Signals

Figure 2.1 shows the input and output connectors on the rear panel.

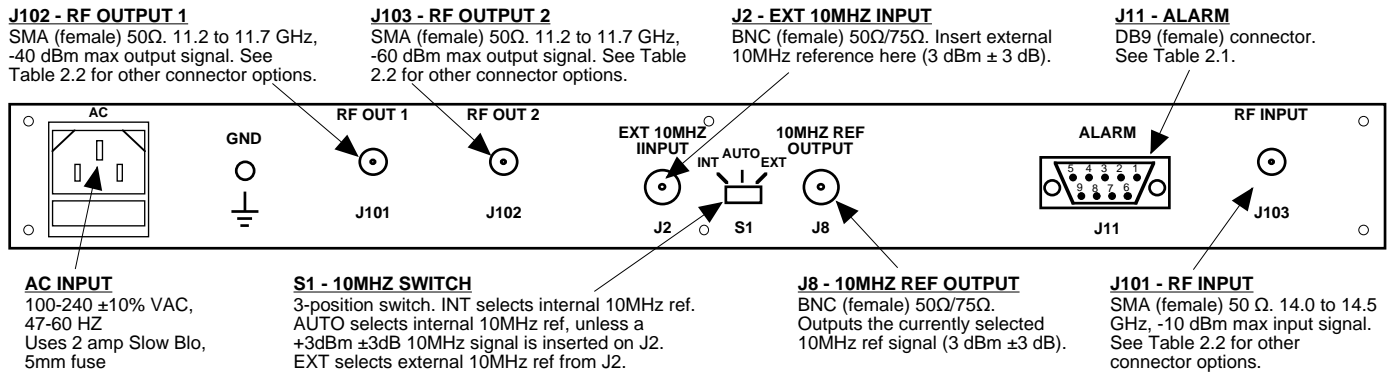

FIGURE 2.1 2116-14T17 Rear Panel I/O's

Pin	Function
1	Not Used
2	Not Used
3	Not Used
4	Not Used
5	GND
6	Alarm Relay: Common
7	Alarm Relay: Normally Open
8	Not Used
9	Alarm Relay: Normally Closed

Option	L-Band	RF
STD	SMA, 50Ω	SMA, 50Ω
SS	Type N, 50Ω	Type N, 50Ω

2.3 Front Panel Indicators

Figure 2.2 shows the front panel indicators.

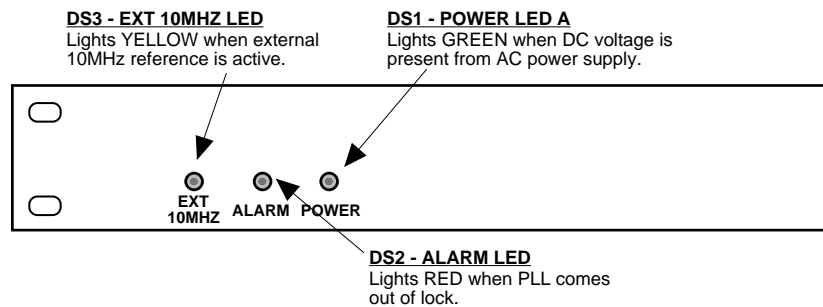

FIGURE 2.2 2116-14T17 Front Panel Controls and Indicators

2.4 Installation / Operation

2.4.1 Installing and Operating the 2116-14T17 Block Translator

1. Connect a -30 dBm to 0 dBm signal to RF INPUT (J101) (Figure 2.1).
2. Connect RF OUT 1 and RF OUT 2 (J102 and J103) to the external equipment.
3. Connect a 100-240 \pm 10% VAC, 47 - 63 Hz to AC connector on the back panel.
4. Be sure DS1 (green, DC Power) is on and DS2 (red, Alarm) is off (Figure 2.2).
5. Select either INT (for internal 10MHz ref), AUTO (for internal 10MHz ref UNLESS an external 10MHz, 3 dBm signal is connected to J2), or EXT (for external 10MHz, 3 dBm ref that is inserted at J2) using the rear panel 3-way switch, S1 (Figure 2.1).
6. If EXT is selected or AUTO is selected and there is a 10MHz, 3 dBm signal at J2, check that DS3 (yellow, Ext 10MHZ) is on (Figure 2.2).
7. Check that a 10MHz, 3 dBm \pm 3 dB signal is present at the 10MHZ REF OUTPUT (J8) (Figure 2.1).
8. **AC Fuse** - The fuse is a 5 mm X 20 mm, 2 amp slow blow (Type T) and is inserted in the far slot in the drawer below the AC input as shown in Figure 2.3. There is a spare fuse in the near slot. If a fuse continues to open, the power supply is most likely defective.

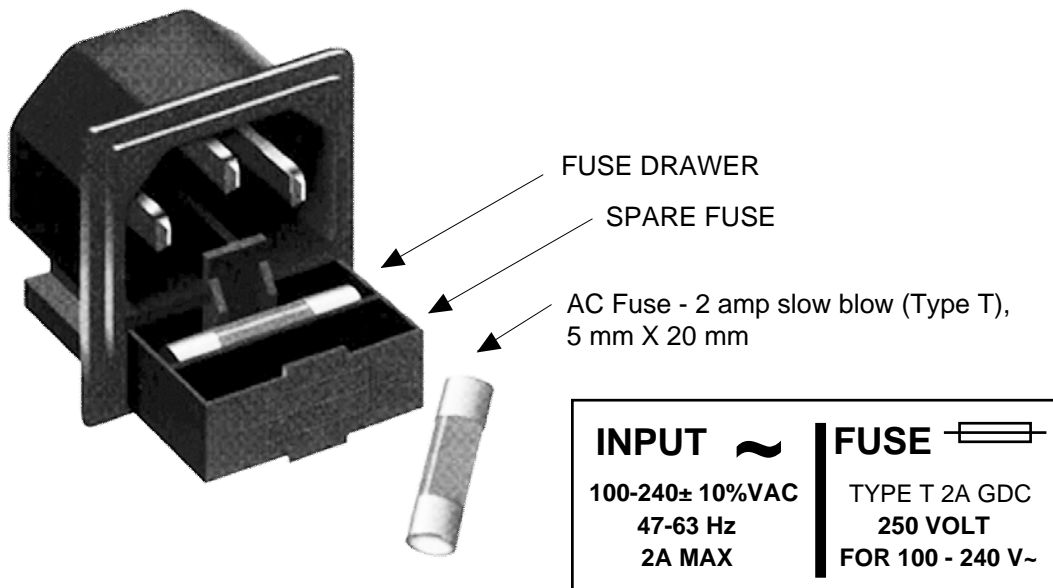

FIGURE 2.3 Fuse Location and Spare Fuse



6170 Shiloh Road
Alpharetta, Georgia 30005

(770) 886-8005
FAX (770) 886-7964
Toll Free 888-900-5588

WEB www.crosstechnologies.com
E-MAIL info@crosstechnologies.com

Printed in USA