

Instruction Manual

Model 2017-2016 Up/Downconverter

September 2012, Rev. 0

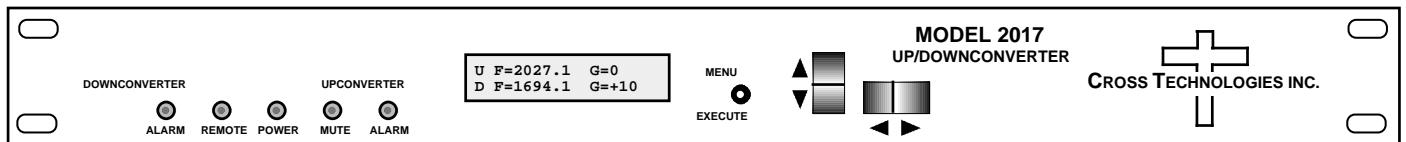

Data, drawings, and other material contained herein are proprietary to Cross Technologies, Inc., but may be reproduced or duplicated without the prior permission of Cross Technologies, Inc. for purposes of operating the equipment. Printed in USA.

When ordering parts from Cross Technologies, Inc., be sure to include the equipment model number, equipment serial number, and a description of the part.



6170 Shiloh Road
Alpharetta, Georgia 30005

(770) 886-8005
FAX (770) 886-7964
Toll Free 888-900-5588

WEB www.crosstechnologies.com
E-MAIL info@crosstechnologies.com

INSTRUCTION MANUAL

MODEL 2017-2016 Up/Downconverter

<u>TABLE OF CONTENTS</u>	<u>PAGE</u>
Warranty	2
1.0 General	3
1.1 Equipment Description	3
1.2 Technical Characteristics	4
1.3 Monitor & Control Interface	5
2.0 Installation	9
2.1 Mechanical	9
2.2 Rear I/O's	10
2.3 Front Panel Controls, Indicators	11
2.4 Operation	12
2.5 Menu Settings	14
3.0 Environmental Use Information	17

WARRANTY - The following warranty applies to all Cross Technologies, Inc. products.

All Cross Technologies, Inc. products are warranted against defective materials and workmanship for a period of one year after shipment to customer. Cross Technologies, Inc.'s obligation under this warranty is limited to repairing or, at Cross Technologies, Inc.'s option, replacing parts, subassemblies, or entire assemblies. Cross Technologies, Inc. shall not be liable for any special, indirect, or consequential damages. This warranty does not cover parts or equipment which have been subject to misuse, negligence, or accident by the customer during use. All shipping costs for warranty repairs will be prepaid by the customer. There are not other warranties, express or implied, except as stated herein.



6170 Shiloh Road
Alpharetta, Georgia 30005

WEB www.crosstechnologies.com
E-MAIL info@crosstechnologies.com

MODEL 2017-2016 Up/Downconverter

1.0 General

1.1 Equipment Description

The 2017-2016 Up/Downconverter converts 70 MHz to 2027.1 MHz (Up) and 1694.1 MHz to 70 MHz (Down) with low group delay and flat frequency response. An integrated Loopback translator is included. Multi-function push button switches select Loopback, the reference mode and remote interface parameters. Front panel LEDs provide indication of DC power (green), PLL alarm for up and downconverters (red), remote operation (yellow), and Upconverter mute (yellow). Gain is fixed at 0 dB for the upconverter, +10 dB for the downconverter and -10dB for Loopback. Remote operation allows selection of all user front panel settings with the exception of remote interface. Frequency and gain appear on the LCD display except when Loopback is indicated. All connectors are 50Ω BNC female. The unit is powered by a 100-240 ± 10% VAC power supply and housed in a 1.75" X 19" X 16" 1RU chassis.

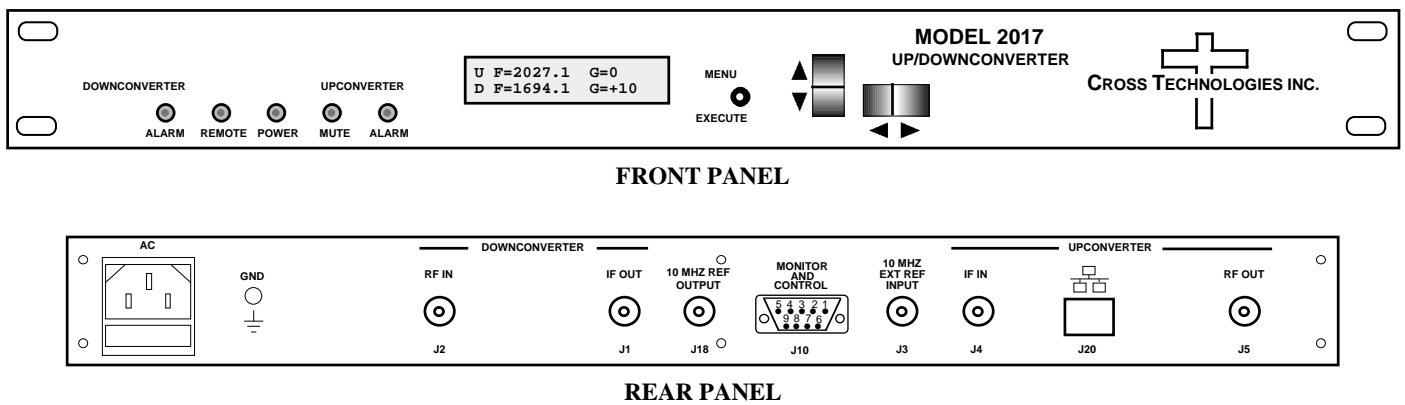

Figure 1.1 Model 2017-2016 Front and Rear Panels

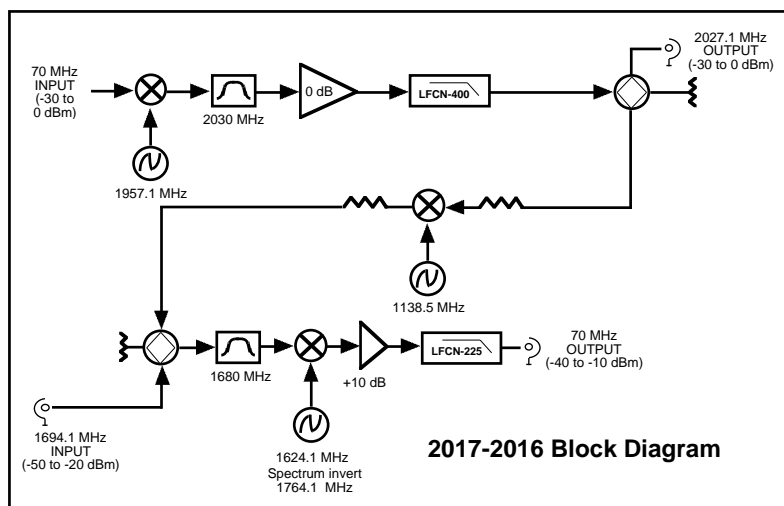

Figure 1.2 Model 2017-2016 Up/Downconverter Block Diagram

1.2 Technical Characteristics

TABLE 1.0 2017-2016 Up/Downconverter Specifications*

UPCONVERTER		DOWNCONVERTER			
Input Characteristics (IF)		Input Characteristics (RF)			
Impedance/Return Loss	50Ω / 14 dB	Impedance/Return Loss	50Ω / 14 dB		
Frequency	70 ± 10 MHz	Frequency	1694.1 MHz		
Input Level	0 to -30 dBm	Noise Figure (maximum)	15 dBm (max. gain)		
Output Characteristics (RF)		Input Level	-50 to -20 dBm		
Impedance/Return Loss	50Ω / 14 dB	Input 1 dB compression	-10 dBm		
Frequency	2027.1 MHz	Output Characteristics (IF)			
Output Level	0 to -30 dBm	Impedance/Return Loss	50Ω / 14 dB		
Output 1 dB compression	+10 dBm	Frequency	70 ± 10 MHz		
Channel Characteristics		Output Level Range	-40 dBm to -10 dBm		
Gain Range	0 dB, Fixed	Output 1 dB compression	0 dBm		
Frequency Sense	Non-inverting	Channel Characteristics			
		Gain Range (fixed)	+10 dB		
		Image Rejection	> 50 dB, min.		
		Frequency Sense	Selectable		
UPCONVERTER AND DOWNCONVERTER					
Channel Characteristics					
Frequency Response	±0.5 dB, 20 MHz BW (±1.0 dB Loopback)				
Spurious Response	<-50 dBC				
Group Delay (max.)	0.015 ns / MHz ² parabolic; 0.05 ns/MHz linear; 1 ns ripple				
Loopback Gain	-10 dB				
Synthesizer Characteristics					
Frequency Accuracy	± 1 ppm				
Frequency Step	Fixed				
Phase Noise @ Frequency	100 MHz	1kHz	10kHz	100kHz	1MHz
dBC/Hz	-70	-70	-80	-90	-100
10 MHz In/Out Level	+3 dBm ± 3 dB (Option E)				
Controls, Indicators					
Frequency/Gain Indication	Direct readout LCD; no control				
Power; Alarm; Remote	Green LED; Red LED; Yellow LED				
Remote	RS232C, 9600 baud (Options RS485/Ethernet, Q / W8, W18)				

Technical Characteristics continued on next page...

Technical Characteristics continued from page 4...

TABLE 1.0 2017-2016 Up/Downconverter Specifications* continued...

Other	
RF In Connectors	BNC Female; 50Ω
IF Connectors	BNC Female; 50Ω
10 MHz Connectors	BNC Female; 50Ω (Option E)
Alarm/Remote Connector	DB9 - NO or NC contact closure on alarm
Size	19 inch, 1RU Standard Chassis, 1.75" High x 16.0" Deep
Power	100-24 ±10% VAC, 47-63 Hz, 45 watts max.
Available Options	
E -	External 10 MHz Reference
H -	High Stability (±0.01ppm) Internal Reference
M&C Remote Interfaces:	
Q -	RS485
W8 -	Ethernet with Web Browser
W18 -	Ethernet with Web Browser & SNMP
W28 -	Ethernet with TCP, IP
W77 -	FP Monitors IF/RF (BNC/SMA)
Connectors/Impedance	See Table 2.2
*10°C to 40°C; Specifications subject to change without notice.	
Cross Technologies, Inc. 2012	

1.3 Monitor and Control Interface

A) Remote serial interface

Protocol: RS-232C, 9600 baud rate, no parity, 8 data bits, 1 start bit, and 1 stop bit.
(RS-232C, **RS-422** and **RS-485 - Option -Q**)

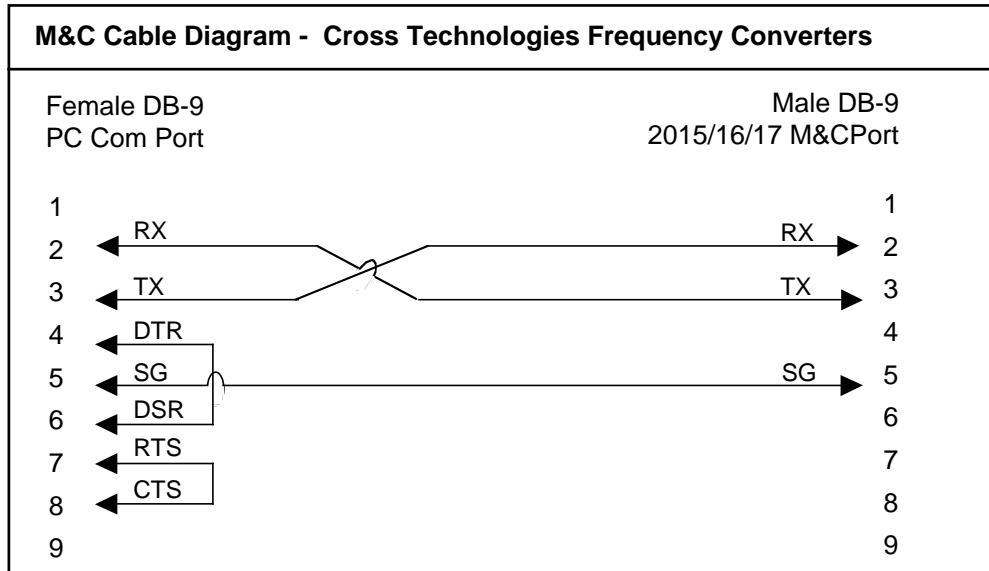

Connector: Rear panel, DB-9 female

J10 Pinouts (RS-232C/422/485)	
Pin	Function
1	Rx-
2	Rx+ (RS-232C)
3	Tx+ (RS-232C)
4	Tx-
5	GND
6	Alarm Relay: Common
7	Alarm Relay: Normally Open
8	Not Used
9	Alarm Relay: Normally Closed

B) Status Requests

Table 1.1 lists the status requests for the 2017-2016 and briefly describes them.

* PLEASE NOTE: The two character {aa}(00-31) prefix, in the table below, should be used ONLY when RS-485, (OPTION-Q), is selected.

Table 1.1 2017-2016 Status Requests		
Command	Syntax*	Description
Status	{aaS1}	Returns {aaS1bcdefg} where:
		b= Downconverter Spectrum Invert status;
		0 = not inverted,1=inverted
		c= Downconverter Alarm status;
		0 = not alarmed,1=alarmed
		d= Upconverter Alarm status;
		0 = not alarmed,1=alarmed
		e= Loopback Alarm status;
		0 = not alarmed,1=alarmed
		f= Summary Alarm status;
		0 = not alarmed,1=alarmed
		g= Upconverter Mute status;
		1 = not muted (carrier on),
		0 = muted (carrier off)
Get 10 MHz Reference Status (Option E)	{aaS2}	Returns {aaS2x} where:
		x = 0 if Internal 10 MHz Reference is selected,
		x = 1 if External 10 MHz Reference is selected
Get IP address (Option W8, W18, W28)	{aaSi}	Returns {aaSixxx.xxx.xxx.xxx} where:
		xxx.xxx.xxx.xxx = IP address
Get subnet mask (Option W8, W18, W28)	{aaSs}	returns {aaSsxxx.xxx.xxx.xxx} where:
		xxx.xxx.xxx.xxx = subnet mask
Get product/model info	{aaSV}	Returns {aaSV2017-2016y..yverZZZZ} where:
		2017-2016 = product model
		y..y = list of options, if any
		"ver" = separates model & options from firmware version

C) Commands

Table 1.2 lists the commands for the 2017-2016 and briefly describes them. After a command is sent the 2017-2016 sends a return “>” indicating the command has been received and executed.

General Command Format - The general command format is {aaCND...}, where:

- { = start byte
- aa = address (RS-485 only **option -Q**)
- C = 1 character, either C (command) or S (status)
- N = 1 character command or status request
- D = 1 character or more of data (depends on command)
- } = stop byte

* PLEASE NOTE: The two character {aa}(00-31) prefix, in the table below, should be used ONLY when RS-485, (OPTION-Q), is selected.

Table 1.2 2017-2016 Commands		
Command	Syntax*	Description
Set Downconverter Spectrum Invert	{aaC7x}	x=1 to enable Spectrum Invert; 0 to disable Spectrum Invert
Set External Reference Mode (Option E)	{aaCEx}	x=1 to operate the unit from an external 10 MHz reference x= 0 to operate the unit from the built in internal 10 MHz reference
Set Upconverter Mute	{aaCAx}	Upconverter Upconverter
Set IF (70 MHz) loopback mode	{aaCLx}	x= 1 to enable loopback (the 70 MHz IF input is looped back to the 70 MHz output) x= 0 to disable loopback
Set remote off	{aaCRO}	subsequent remote commands are ignored until remote it turned back on.

2.0 Installation

2.1 Mechanical

The 2017-2016 consists of one RF/Controller PCB housed in a 1 RU (1 3/4 inch high) by 16 inch deep chassis. A switching, ± 12 , +5, +24 VDC power supply provides power for the assemblies. The 2017-2016 can be secured to a rack using the 4 holes on the front panel. Figure 2.0 shows how the 2017-2016 is assembled.

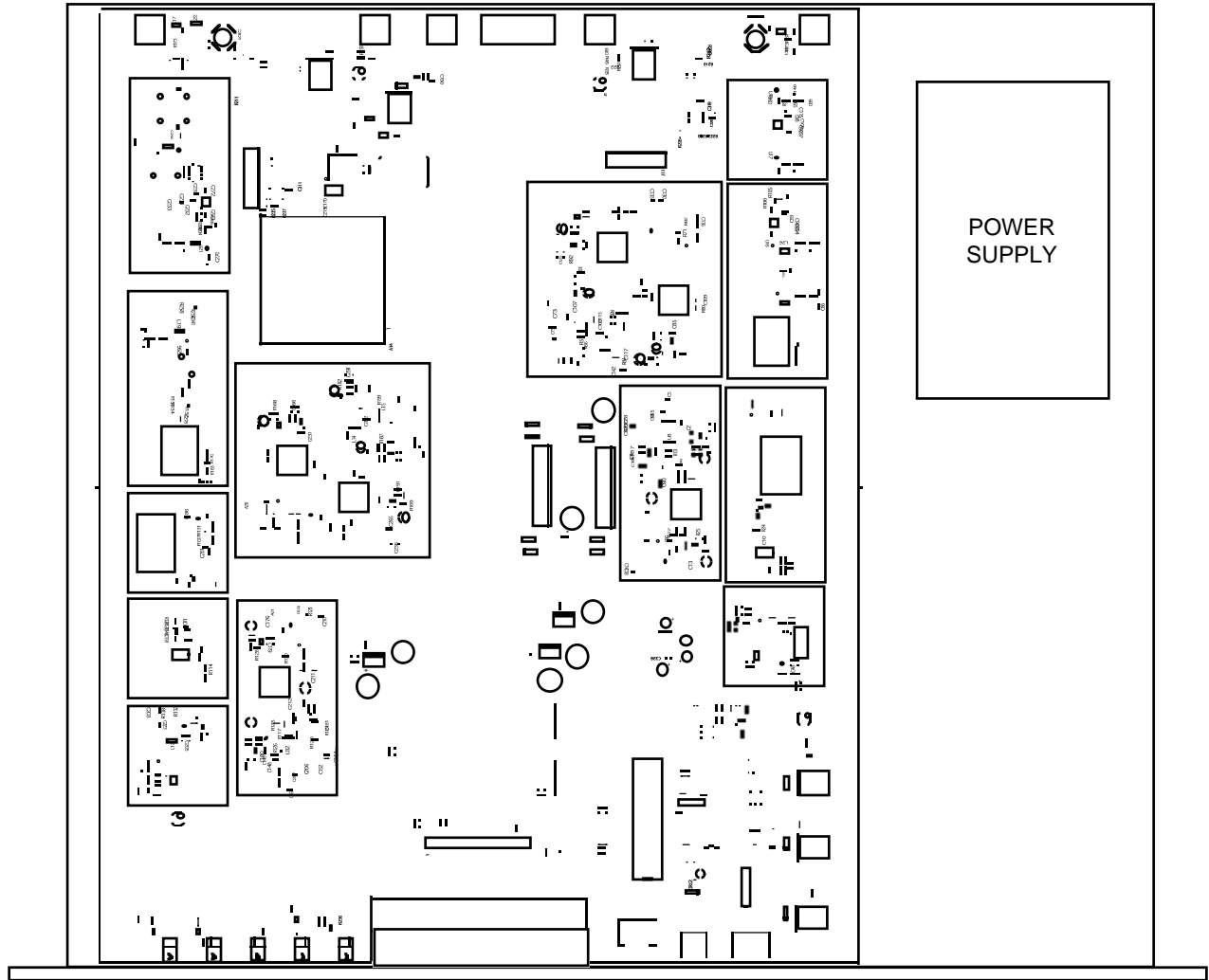

Figure 2.0 Model 2017-2016 Mechanical Assembly

2.2 Rear Panel Input/Output Signals and Control -

Figure 2.1 shows the input and output connectors on the rear panel.

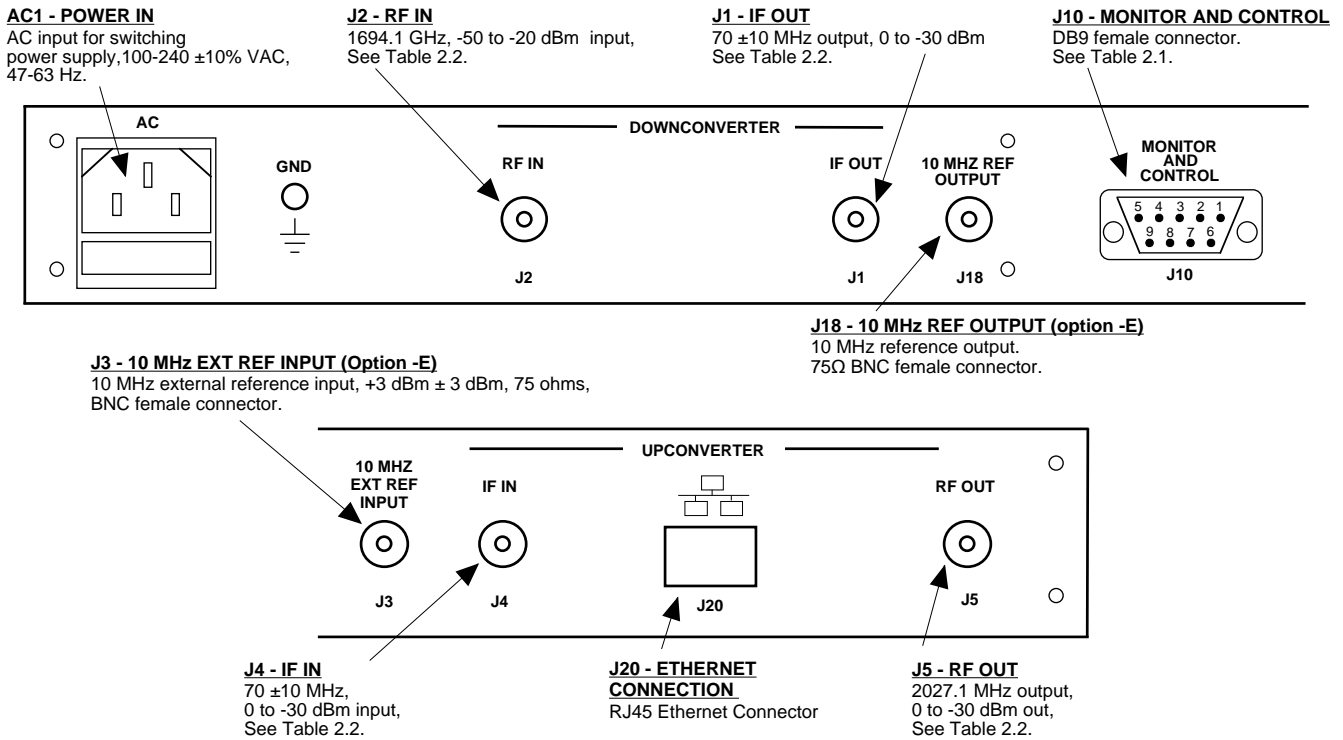

Figure 2.1 Model 2017-2016 Rear Panel I/O's

TABLE 2.1 J10 Pinouts (RS-232C/422/485*)	
Pin	Function
1	Rx-
2	Rx+ (RS-232C)
3	Tx+ (RS-232C)
4	Tx-
5	GND
6	Alarm Relay: Common
7	Alarm Relay: Normally Open
8	Not Used
9	Alarm Relay: Normally Closed

*Remote Serial Interface

Interface: DB-9 Male

Protocol: RS-232C (RS-232C/422/485 **option -Q**), 9600 baud rate, no parity, 8 data bits, 1 start bit, 1 stop bit.

TABLE 2.2 IF/RF Connector Options		
Option	IF	RF
-M	BNC, 50 Ω	Type N, 50 Ω

2.3 Front Panel Controls and Indicators - The following are the front panel controls and indicators.

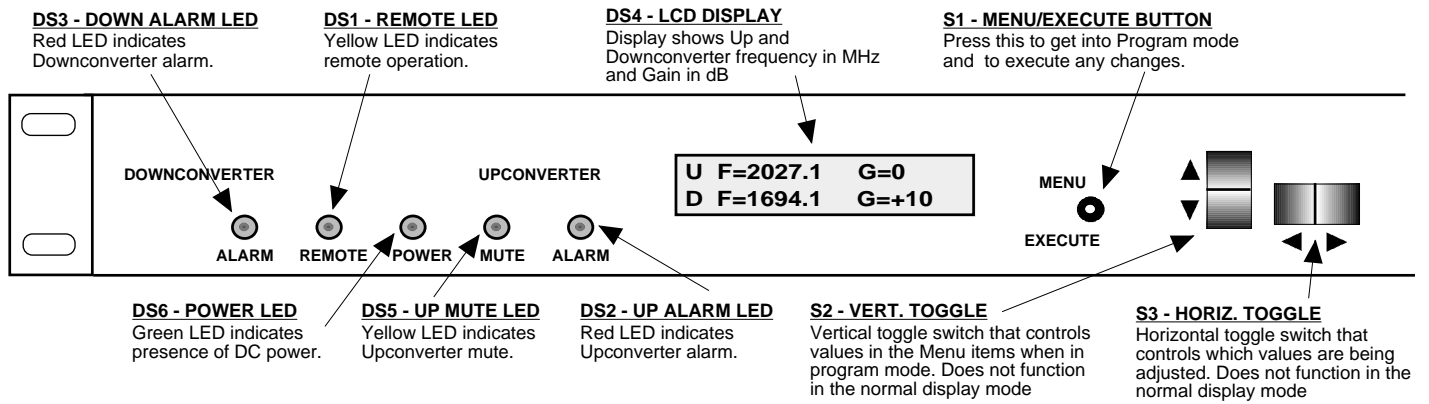

Figure 2.2 Model 2017-2016 Front Panel Controls and Indicators

2.4 Installation / Operation

2.4.1 Installing and Operating the 2017-2016, Upconverter Section

- 1.) Connect a 0 dBm to -30 dBm signal to IF In, J4 (Figure 2.1).
- 2.) Connect the RF OUT, J5, to the external equipment.
- 3.) Connect 100-240 \pm 10% VAC, 47 - 63 Hz, 45 watts max., to AC on the back panel.

2.4.2 Installing and Operating the 2017-2016, Downconverter Section

- 1.) Connect a -50 dBm to -20 dBm signal to RF In, J2 (Figure 2.1).
- 2.) Connect the IF OUT, J1, to the external equipment.
- 3.) Connect 100-240 \pm 10% VAC, 47 - 63 Hz, 45 watts max., to AC on the back panel.
- 4.) Be sure DS6 (green, DC Power) is on and DS2 & DS3 (red, Alarm) are off (Figure 2.2).
- 5.) **AC Fuse** - The fuse is a 5 mm X 20 mm, 2 amp slow blow (Type T) and is inserted in the far slot in the drawer below the AC input as shown in Figure 2.3. There is a spare fuse in the near slot.
If a fuse continues to open, the power supply is most likely defective.

2.4.3 External 10 MHz Reference Operation

The External Reference Option is required if the unit is to synch to a 10 MHz reference from an *external* source. The unit will still have an internal 10 MHz reference as a 'back-up' should the external reference be removed or fail. Described below are the two (2), 10 MHz External Reference Options, Option E & E1.

Option E

Internal Reference Mode

When the internal reference mode is selected, the unit's internal 10 MHz reference will become the 'primary' source and the unit's synthesizers will lock to this internal 10 MHz reference. The unit will ignore any external 10 MHz signal present on the external reference input (J3 in figure 2.1). The unit will also buffer the internal 10 MHz signal and provide it on the Reference Out connector (J18 in figure 2.1) at +3 dBm, +/- 3 dB.

External Reference Mode

When the external reference mode is selected, the external 10 MHz reference (received on J3) will become the 'primary' source and the unit's synthesizers will lock to this external 10 MHz reference. The unit *must* have a 10 MHz signal connected to the external reference input (J3) on the rear panel. The external 10 MHz signal must be +3 dBm, +/- 3 dB. The unit will also buffer the external 10 MHz signal and provide it on the Reference Out connector (J18) at +3 dBm, +/- 3 dB.

NOTE: There is no "auto-detect" capability in Option E. [See Option E1 below if this capability is required.] If the External Reference Mode is selected and the external reference fails or is removed, the unit will ALARM, but it will NOT automatically switch to the internal reference. The user will be required to manually select Internal Reference Mode (via the front panel LCD or Remote M&C) for the *internal* 10 MHz reference to become the 'primary' source for the unit.

Once the external 10 MHz reference is restored (on J13), the user must again manually (via the front panel LCD or Remote M&C) reselect External Reference Mode for the *external* 10 MHz reference to become the 'primary' source.

L-band units with Option E also have the ability to 'insert' the (internal or external) 10 MHz signal that has been buffered (as described above) on the center pin of the L-band (RF) connector(s).

Option E1

Units with option E1 operate as described above but also have an Auto mode. When in auto mode the unit will detect and select the external 10 MHz signal if it is present and at least +3 dBm. If the external 10 MHz signal falls below 1 dBm (+/- 1 dB) the unit will automatically switch to the internal 10 MHz reference. The reference out connector (J18) provides a buffered rendition of the selected 10 MHz signal at +3 dBm, +/- 3 dB.

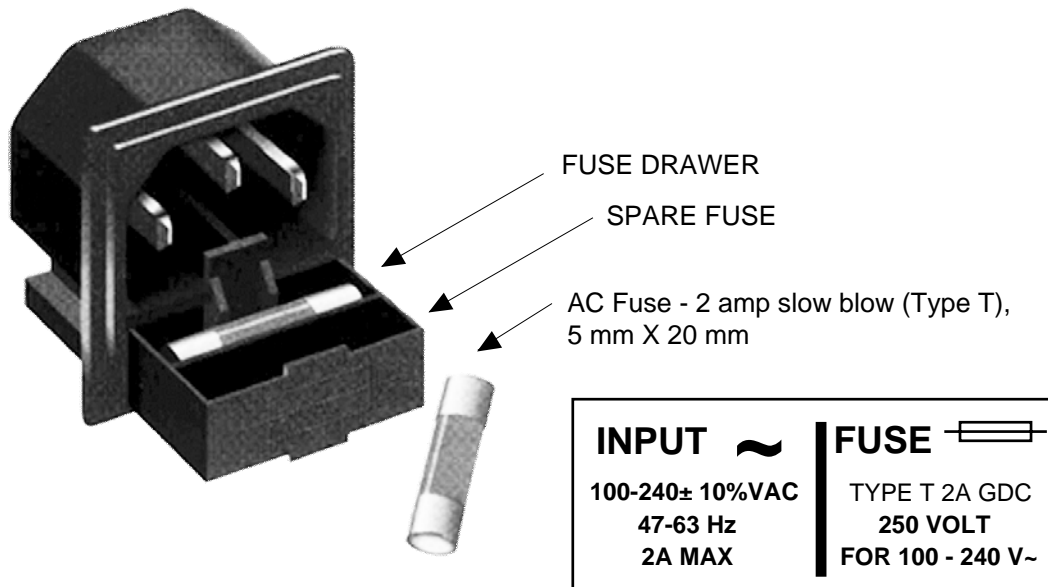

Figure 2.3 Fuse Location and Spare Fuse

2.5 Menu Settings

2.5.1 Functions - This section describes operation of the front panel controls. There are three operator switches, the LCD display and alarm indicator LEDs. All functions for the equipment are controlled by these components. The functions are (see Figure 2.2):

Power Up

Normal Display

Menu 1	Set Loopback
Menu 2	Set Downconverter Spectrum Sense
Menu 3	Up Mute
Menu 4	Set Unit to Remote Operation
Menu 5	Set Remote Interface
Menu 6	Set RS-485 address (Option -Q)
Menu 7	Select External 10 MHz Reference (Option -E) (Option -E1)
Menu 8	View PCB Temperature (Option -T)

Save Menu When go to end

Alarm indications appear on the LEDs (see figure 2.2).

All program changes must start with the operation of the Menu/Execute switch and must also end with the operation of the Menu/Execute switch verified by the "Save Settings?" Menu. If this sequence is not followed, none of the changes will take effect. If programming is initiated and no operator action takes place for approximately 30 seconds (before the final press of the Menu/Execute switch) the display will revert to its previous status and you will need to start over.

2.5.2 Power-On Settings

NOTE: THE LAST STATUS OF A UNIT IS RETAINED EVEN WHEN POWER IS REMOVED. WHEN POWER IS RESTORED, THE UNIT WILL RETURN TO IT'S PREVIOUS SETTINGS.

When power is first applied, the LCD display goes through three steps.

1. The LCD goes black to show all segments are functioning.
2. The model number with options software version will be displayed.

2017-2016E1W8X 4.00

3. The present frequency and gain of the up and Downconverter is shown.

U F=2027.1 G=0
D F=1694.1 G=+10

The unit is now operational and ready for any changes the operator may desire.

2.5.3 Control Switches

1. Menu/Execute - Any change to the programming of the unit must be initiated by pressing the Menu/Execute switch and completed by pressing the Menu/Execute switch.
2. Horizontal Switch - This switch is mounted so its movement is horizontal and moves the cursor left or right.
3. Vertical Switch - This switch is mounted so its movement is vertical and has two functions:
 - a. During frequency , gain, input level changes, the vertical movement will raise or lower the number in the direction of the arrows.
 - b. For other functions such Mute on/off, the vertical switch will alternately turn the function on or off regardless of the direction operated.

2.5.4 Alarm Indications

An alarm condition will occur if any local oscillator phase lock loop (PLL) comes out of lock.

Power Up	ON POWER UP 2017-0415E1W8X 4.00		
Normal Display	NORMAL DISPLAY U F = 2027.1 G = 0 D F = 1694.1 G = +10		PUSH BUTTON
Menu 1 Set Loopback	PUSHING MENU/EXECUTE SEQUENCE LOOPBACK <u>ON</u>	SCROLL <> SCROLL ↻	PUSH BUTTON
Menu 2 Set Downconverter Spectrum Sense	DNSPECTRUM <u>NON</u> R	SCROLL <> SCROLL ↻	PUSH BUTTON
Menu 3 Up Mute	UP MUTE <u>OFF</u> R	SCROLL <> SCROLL ↻	PUSH BUTTON
Menu 4 Set Unit to Remote Operation	REMOTE <u>OFF</u> R	SCROLL <> SCROLL ↻	PUSH BUTTON
Menu 5 Set Remote Interface	INTERFACE <u>RS232</u> R	SCROLL <> SCROLL ↻	PUSH BUTTON
Menu 6 Set RS-485 Address (Option -Q)	ADDRESS = <u>00</u> R	SCROLL <> SCROLL ↻	PUSH BUTTON
Menu 7 Select External 10 MHz Reference (Option -E)	REF MODE <u>INT</u> R	SCROLL <> SCROLL ↻	PUSH BUTTON
Save Settings? At the end or when "R" is selected from any of the above menus.	SAVE SETTINGS? <u>Y</u> N	SCROLL <>	PUSH BUTTON

Figure 2.4 Menu Display and Sequence

3.0 Environmental Use Information

- A. **Rack-Mounting** - To mount this equipment in a rack, please refer to the installation instructions located in the user manual furnished by the manufacturer of your equipment rack.
- B. **Mechanical loading** - Mounting of equipment in a rack should be such that a hazardous condition does not exist due to uneven weight distribution.
- C. **Elevated operating ambient temperature** - If installed in a closed or multi-unit rack assembly, the operating ambient temperature of the rack may be greater than room ambient temperature. Therefore, consideration should be given to Tmra.
- D. **Reduced air flow** - Installation of the equipment in a rack should be such that the amount of air flow required for safe operation of the equipment is not compromised. Additional space between units may be required.
- E. **Circuit Overloading** - Consideration should be given to the connection of the equipment to the supply circuit and the effect that overloading of circuits could have on over current protection and supply wiring. Appropriate consideration of equipment name plate rating should be used, when addressing this concern.
- F. **Reliable Earthing** - Reliable earthing of rack-mounted equipment should be maintained. Particular attention should be given to supply connections other than direct connection to the Branch (use of power strips).
- G. **Top Cover** - There are no serviceable parts inside the product so, the Top Cover should not be removed. If the Top Cover is removed the ground strap and associated screw **MUST BE REINSTALLED** prior to Top Cover screw replacement. **FAILURE TO DO** this may cause **INGRESS** and/or **EGRESS** emission problems.



6170 Shiloh Road
Alpharetta, Georgia 30005

(770) 886-8005
FAX (770) 886-7964
Toll Free 888-900-5588

WEB www.crosstechnologies.com
E-MAIL info@crosstechnologies.com

Printed in USA