

Instruction Manual

Model 2016-275 Downconverter

October 2011, Rev. B

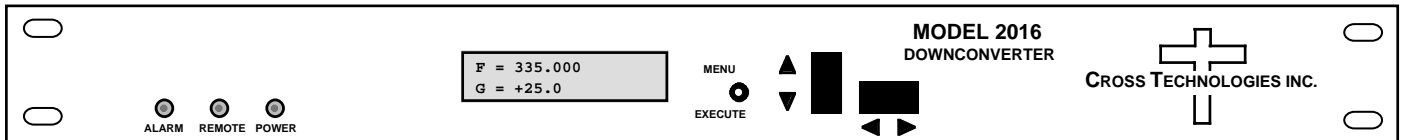

Data, drawings, and other material contained herein are proprietary to Cross Technologies, Inc., but may be reproduced or duplicated without the prior permission of Cross Technologies, Inc. for purposes of operating the equipment.

When ordering parts from Cross Technologies, Inc., be sure to include the equipment model number, equipment serial number, and a description of the part.



6170 Shiloh Road
Alpharetta, Georgia 30005

(770) 886-8005
FAX (770) 886-7964
Toll Free 888-900-5588

WEB www.crosstechnologies.com
E-MAIL info@crosstechnologies.com

INSTRUCTION MANUAL

MODEL 2016-275 Downconverter

<u>TABLE OF CONTENTS</u>	<u>PAGE</u>
Warranty	2
1.0 General	3
1.1 Equipment Description	3
1.2 Technical Characteristics	4
1.3 Monitor & Control Interface	5
1.4 Environmental Information	8
2.0 Installation	9
2.1 Mechanical	9
2.2 Rear Panel Inputs & Outputs	10
2.3 Front Panel Controls & Indicators	10
2.4 Operation	11
2.5 Menu Settings	12

WARRANTY - The following warranty applies to all Cross Technologies, Inc. products.

All Cross Technologies, Inc. products are warranted against defective materials and workmanship for a period of one year after shipment to customer. Cross Technologies, Inc.'s obligation under this warranty is limited to repairing or, at Cross Technologies, Inc.'s option, replacing parts, subassemblies, or entire assemblies. Cross Technologies, Inc. shall not be liable for any special, indirect, or consequential damages. This warranty does not cover parts or equipment which have been subject to misuse, negligence, or accident by the customer during use. All shipping costs for warranty repairs will be prepaid by the customer. There are not other warranties, express or implied, except as stated herein.



6170 Shiloh Road
Alpharetta, Georgia 30005

(770) 886-8005
FAX (770) 886-7964
Toll Free 888-900-5588
WEB www.crosstechnologies.com
E-MAIL info@crosstechnologies.com

MODEL 2016-275 L-Band Downconverter

1.0 General

1.1 Equipment Description

The 2016-275 L-band Downconverter converts 250 - 750 MHz to 70 ± 18 MHz in 1 kHz, 10 kHz, 100 kHz, or 125 kHz steps (user selectable) with low group delay and flat frequency response. Synthesized local oscillators (LO) provide very low phase noise and ± 0.01 ppm stability frequency selection. Multi-function push button switches select the RF frequency, gain, and other parameters. Front panel LEDs provide indication of DC power (green), PLL alarm (red), and remote operation (yellow). Gain is adjustable manually over a 0 to +50 dB range as adjusted by the front panel multi-function push-button switches. Remote operation allows selection of frequency and gain. Parameter selection and frequency and gain settings appear on the LCD display. Connectors are BNC female for IF output and the optional external reference input and output, and Type F female for the RF input. The 10 MHz option also includes a 10 MHz output connector, which contains either the internal or external 10 MHz reference signal. The unit is powered by a 100-240 $\pm 10\%$ VAC power supply, and housed in a 1 3/4" X 19" X 16" rack mount chassis.

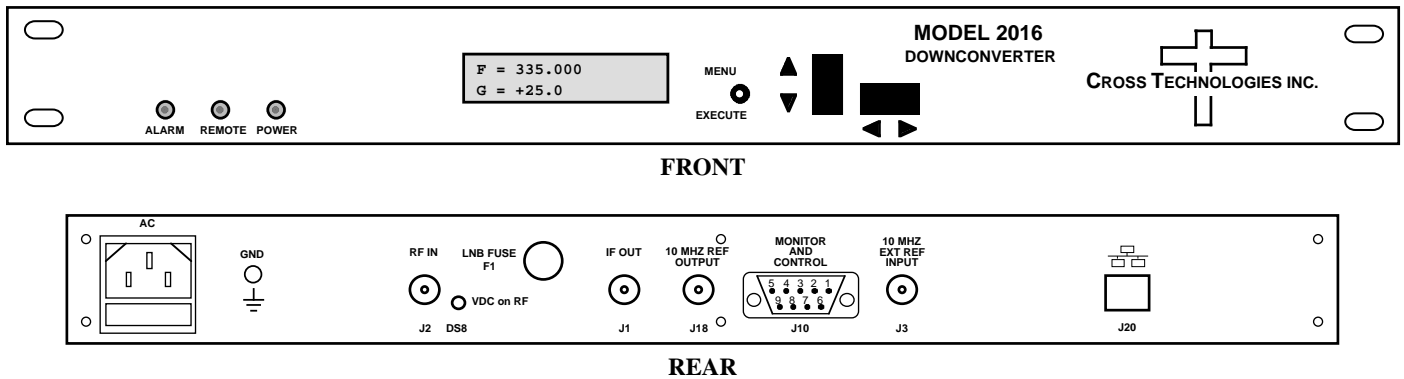

FIGURE 1.1 Front and Rear Panels

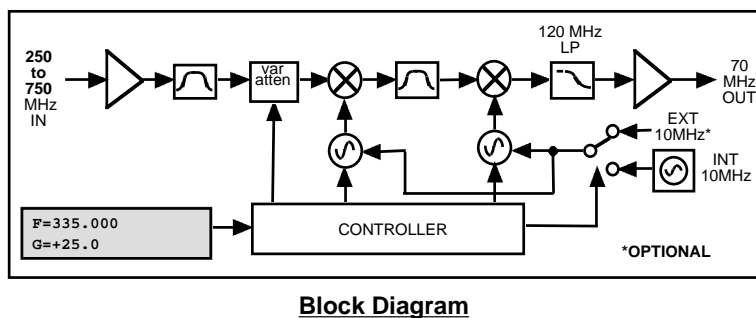

FIGURE 1.2 Block Diagram

1.2 Technical Characteristics

TABLE 1.0 2016-275 Downconverter Specifications*

Input Characteristics

Impedance/Return Loss	75Ω /12 dB
Frequency	250 to 750 MHz
Noise Figure, max.	15 dB (max. gain)
Input Level Range	-70 to -20 dBm
Input 1dB compression	-15 dBm

Output Characteristics

Impedance	75 Ω (see TABLE 2.2 for connector options)
Return Loss	18 dB
Frequency	70 ± 18 MHz
Output Level/Max linear	-20 dBm / -10 dBm
1dB compression	-5 dBm

Channel Characteristics

Gain range (adjustable)	0.0 to +50.0 dB
Image Rejection	> 50 dB, min.
Frequency Response	±1.5 dB, 250 to 750 MHz ; ± 0.5 dB, 36 MHz BW
Spurious Response	< -50 dBc, in band
Group Delay, max.	0.01 ns/MHz ² parabolic; 0.03 ns/MHz linear; 1 ns ripple
Frequency Sense	Inverting or Non-inverting, selectable

Synthesizer Characteristics

Frequency Accuracy	±0.01 ppm internal reference
Frequency Step	1kHz, 10kHz, 100kHz, or 125 kHz (user selectable)
10 MHz level (In & Out)	3 dBm ± 3 dB (option E)

Phase Noise @ Freq	100 Hz	1kHz	10kHz	100kHz	1MHz
dBC/Hz	-75	-85	-90	-110	-120

Controls, Indicators

Freq/Gain Selection	Direct readout LCD; manual or remote selection
Power; Alarm; Remote	Green LED; Red LED; Yellow LED
Remote	RS232C, 9600 baud (Options: RS485, Ethernet)

Other

RF, IF Connectors	Type F (female), BNC (female)
10MHz Connectors	BNC (female), 50Ω/75Ω (option E)
Alarm/Remote Connector	DB9 (female) - NO or NC contact closure on Alarm
Size	19 inch, 1RU standard chassis 1.75" high X 16.0" deep
Power	100-240 ± 10% VAC, 47-63 Hz, 45 W max.

Options

-E	External 10 MHz Reference Input and Output
-L	LNB voltage, +24VDC, 0.4 amps, Optional M&C: (RS-232 Std.)
-Q	RS-485 Remote Interface
-T	Temperature Sensor
-W8	Ethernet; with Web Browser
-W18	Ethernet; with SNMP
-W28	Ethernet; TCP/IP addressable
Connector Options	See TABLE 2.2

*+10°C to +40°C; Specifications subject to change without notice

1.3 Monitor and Control Interface

A) Remote serial interface

Protocol - RS-485, RS-422 or RS-232C (selectable), 9600 baud rate, no parity, 8 data bits, 1 start bit, 1 stop bit.

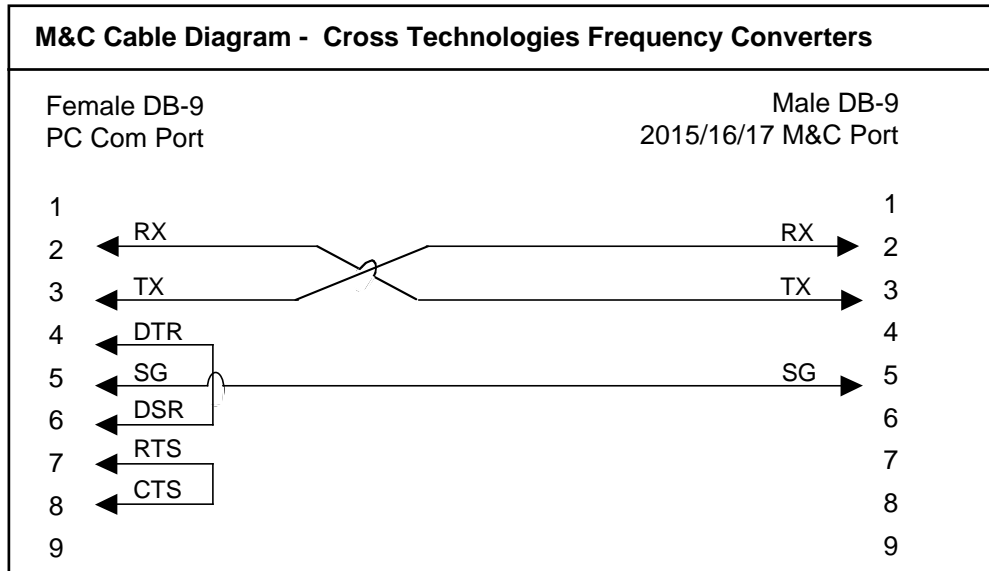

Connector: Rear panel, DB-9 female

Pinouts (RS-485/422/232C)

Pin	Description
1	Rx-
2	Rx+ (RS-232C)
3	Tx+ (RS-232C)
4	Tx-
5	Ground
6	Alarm Relay - Common
7	Alarm Relay - Normally Open
8	Not Used
9	Alarm Relay - Normally Closed

B) Status Requests

Table 1.1 lists the status requests for the 2016-275 and briefly describes them.

* PLEASE NOTE: The two character {aa}(00-31) prefix, in the table below, should be used ONLY when RS-485, (OPTION-Q), is selected.

TABLE 1.1 2016-275 Status Requests		
Command	Syntax*	Description
Command Status	{aaS1}	Returns {S1bbbbbbccIA} where:
		• bbbbbbb = Rx frequency (in kHz)
		• cc = Rx gain
		• I = 1 - spectrum invert enabled
		• A = summary alarm; 1=alarmed, 0=normal
10MHz Ref Status (option E ONLY)	{aaS2}	Returns {S2ER} where:
		• E = 1 - external 10 MHz switched in

C) Commands

Table 1.2 lists the commands for the 2016-275 and briefly describes them. After a command is sent the 2016-275 sends a return “>” indicating the command has been received and executed.

General Command Format - The general command format is {aaCND...}, where:

- { = start byte
- aa = Address (**RS-485 only**)
- C = 1 character, either C (command) or S (status)
- N = 1 character command of status request
- D = 1 character or more of data (depends on command)
- } = stop byte

* PLEASE NOTE: The two character {aa}(00-31) prefix, in the table below, should be used ONLY when RS-485, (OPTION-Q), is selected.

Table 1.2 2016-275 Commands		
Command	Syntax*	Description
Set Receiver Frequency	{aaC2xxxxxxx}	where: <ul style="list-style-type: none"> • xxxxxxx = 7 characters • Range: 0250000 to 750000 kHz, in 1kHz steps min.
Set Receiver Gain	{aaC4xx}	where: <ul style="list-style-type: none"> • xx = 2 characters • Range: 00 to 50 (0 dB to +50 dB, in 1 dB steps)
Enable Spectrum Invert	{aaC7x}	where x =: <ul style="list-style-type: none"> • 0 to disable spectrum invert • 1 to enable spectrum invert
Enable External 10MHz IN (option E ONLY)	{aaCEx}	where x =: <ul style="list-style-type: none"> • 0 to disable External 10MHz ref signal • 1 to enable External 10MHz ref signal
Enable Remote	#	Just # sign
Disable Remote	{aaCRO}	{CR and zero}

1.4 Environmental Information

- A. Rack-Mounting** - To mount this equipment in a rack, please refer to the installation instructions located in the user manual furnished by the manufacturer of your equipment rack.
- B. Mechanical Loading** - Mounting of equipment in a rack should be such that a hazardous condition does not exist due to uneven weight distribution.
- C. Elevated Operating Ambient Temperature** - If installed in a closed or multi-unit rack assembly, the operating ambient temperature of the rack may be greater than room ambient temperature. Therefore, consideration should be given to Tmra.
- D. Reduced Air Flow** - Installation of the equipment in a rack should be such that the amount of air flow required for safe operation of the equipment is not compromised. Additional space between units may be required.
- E. Circuit Overloading** - Consideration should be given to the connection of the equipment to the supply circuit and the effect that overloading of circuits could have on over current protection and supply wiring. Appropriate consideration of equipment name plate rating should be used when addressing this concern.
- F. Reliable Earthing** - Reliable earthing of rack-mounted equipment should be maintained. Particular attention should be given to supply connections other than direct connection to the Branch (use of power strips).
- G. Top Cover** - There are no serviceable parts inside the product so, the Top Cover should not be removed. If the Top Cover is removed the ground strap and associated screw **MUST BE REINSTALLED** prior to Top Cover screw replacement. **FAILURE TO DO** this may cause **INGRESS** and/or **EGRESS** emission problems.

2.0 Installation

2.1 Mechanical

The 2016-275 consists of one RF/Controller PCB housed in a 1 RU (1 3/4 inch high) by 16 inch deep chassis. A switching, ± 12 , +24, +5 VDC power supply provides power for the assemblies. The 2016-275 can be secured to a rack using the 4 holes on the front panel. Figure 2.1 shows how the 2016-275 is assembled.

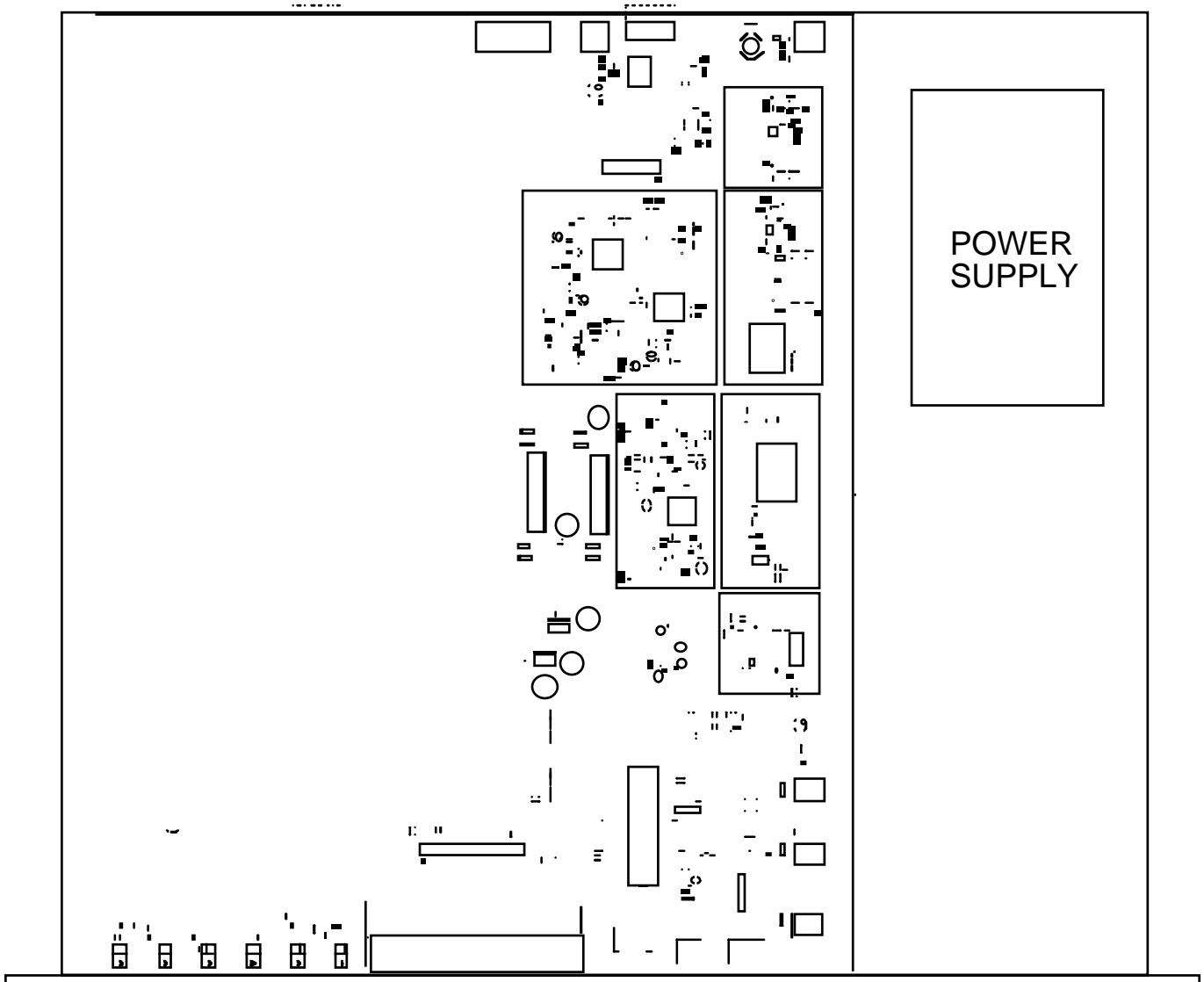

FIGURE 2.1 Mechanical Assembly

2.2 Rear Panel Input/Output Signals

Figure 2.2 shows the input and output connectors on the rear panel.

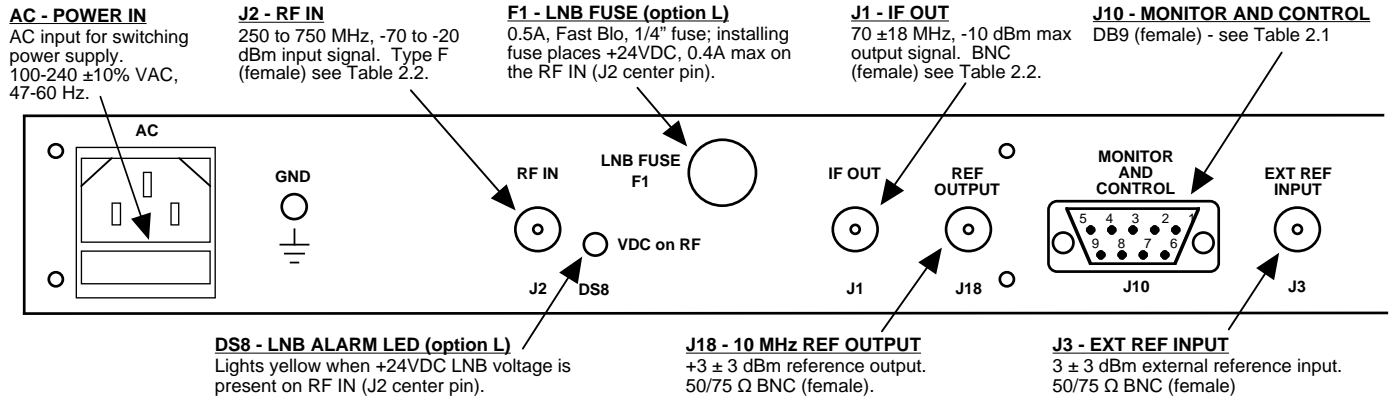

FIGURE 2.2 2016-275 Rear Panel I/Os

Pin	Function
1	Rx-
2	Rx+ (RS-232C)
3	Tx+ (RS-232C)
4	Tx-
5	GND
6	Alarm Relay: Common
7	Alarm Relay: Normally Closed
8	Not Used
9	Alarm Relay: Normally Open

Option	IF	RF
STD	BNC, 75Ω	Type F, 50Ω
B	BNC, 75Ω	BNC, 75Ω
C	BNC, 75Ω	BNC, 50Ω
D	BNC, 50Ω	BNC, 50Ω
M	BNC, 50Ω	Type N, 50Ω
N	BNC, 75Ω	Type N, 50Ω
NN	Type N, 50Ω	Type N, 50Ω

*Remote Serial Interface

Interface: DB-9 Female

Protocol: RS-232C, 9600 baud rate, no parity, 8 data bits, 1 start bit, 1 stop bit

2.3 Front Panel Controls and Indicators

Figure 2.3 shows the front panel controls and indicators.

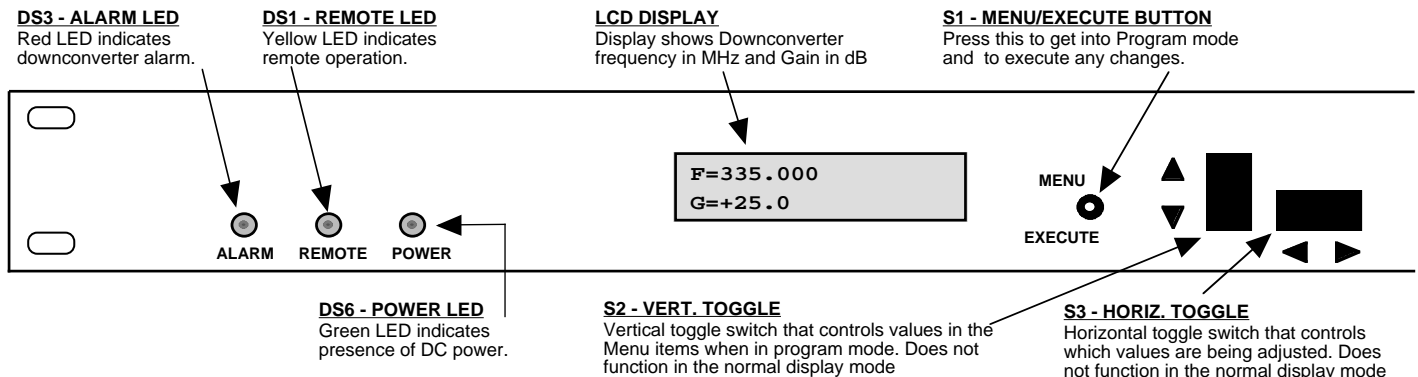

FIGURE 2.3 2016-275 Front Panel Controls and Indicators

2.4 Operation

2.4.1 Installing and Operating the 2016-275 Downconverter

1. Connect a -70 dBm to -20 dBm signal to RF IN, J2 (Figure 2.2)
2. Connect the IF OUT, J1, to the external equipment
3. Connect 100-240 \pm 10% VAC, 47 - 63 Hz to AC on the back panel (Figure 2.2).
4. Set the input frequency (See Section 2.5 Menu Settings).
5. Set the gain for 0 to +50 dB (See Section 2.5 Menu Settings).
6. Be sure DS6 (green, DC Power) is on and DS3 (red, Alarm) is off (Figure 2.3).
7. Option L ONLY - To insert LNB +24 VDC on the RF center pin install 0.5A fast blo fuse (included) in F1 and check that DS8 lights yellow (Figure 2.2)
8. AC Fuse - The fuse is a 5 mm X 20 mm, 2 amp slow blow (Type T) and is inserted in the far slot in the drawer below the AC input as shown in Figure 2.4. There is a spare fuse in the near slot. If a fuse continues to open, the power supply is most likely defective.

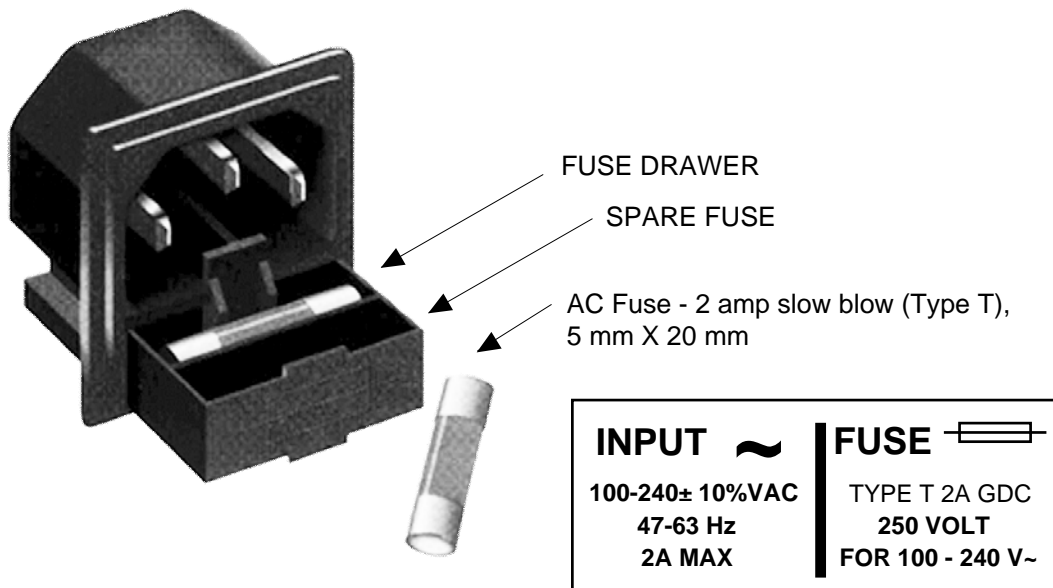

FIGURE 2.4 Fuse Location and Spare Fuse

2.5 Menu Settings

2.5.1 Functions

This section describes operation of the front panel controls. There are three operator switches, the LCD display and alarm indicator LEDs. All functions for the equipment are controlled by these components. The functions are (see Figure 2.5):

Power Up

Normal Display

Menu 1 Frequency in MHz

Menu 2 Gain (0 to +50)

Menu 3 Set Unit to Remote Operation

Menu 4 Select Non-inverting or Inverting Spectrum

Menu 5 Select Frequency Step Size (1kHz, 10kHz, 100kHz, or 125kHz)

Menu 6 Select External 10 MHz Ref (option E)

Menu 7 Set Remote mode (option Q)

Menu 8 Set RS-485 address (option Q)

Save Menu When “R” is selected in any above menu or at the end of the menu options

Alarm indications appear on the LEDs (see figure 2.3).

All program changes must start with the operation of the Menu/Execute switch and must also end with the operation of the Menu/Execute switch verified by the “Save Settings?” Menu. If this sequence is not followed, none of the changes will take effect. If programming is initiated and no operator action takes place for approximately 30 seconds (before the final press of the Menu/Execute switch) the display will revert to its previous status and you will need to start over.

2.5.2 Power On Settings

NOTE: THE LAST STATUS OF A UNIT IS RETAINED EVEN WHEN POWER IS REMOVED. WHEN POWER IS RESTORED, THE UNIT WILL RETURN TO ITS PREVIOUS SETTINGS.

When power is first applied, the LCD display goes through three steps.

1. The LCD goes black to show all segments are functioning.
2. The software version will be displayed.



REV 1.00

3. The present frequency and gain of the downconverter is shown.

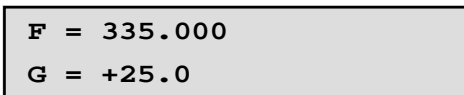

F = 335.000
G = +25.0

The unit is now operational and ready for any changes the operator may desire.

2.5.3 Control Switches

1. Menu/Execute - Any change to the programming of the unit must be initiated by pressing the Menu/Execute switch and completed by pressing the Menu/Execute switch.
2. Horizontal Switch - This switch is mounted so its movement is horizontal and moves the cursor left or right.
3. Vertical Switch - This switch is mounted so its movement is vertical and has two functions:
 - a. During frequency, gain changes, the vertical movement will raise or lower the number in the direction of the arrows.
 - b. For other functions such Mute on/off, the vertical switch will alternately turn the function on or off regardless of the direction operated.

2.5.4 Frequency Changes

At any time during the modification process, if you have made a mistake and do not wish to save the changes you have made, **do not press the Menu/Execute switch**; simply do nothing for approximately 30 seconds, and the system will return to the normal operating mode or scroll to “**R**” and push the menu/Execute switch and select “**NO**” in the “**SAVE SETTINGS?**” window.

To change the FREQUENCY:

Operate the Menu/Execute switch until you get to the menu item you want to change see Figure 2.5 for the sequence of menu options. The following display is for changing the downconverter frequency:

```
F = 335.000
G = +25.0
```

Pressing the Up/Down switch down will toggle the display to:

```
F = 435.000
G = +25.0
```

By using the horizontal rocker switch the cursor can be moved left or right .

```
F = 435.000
G = +25.0
```

NOTE: CHANGES DO NOT TAKE PLACE ON FREQUENCY UNTIL YOU GO TO THE SAVE MENU AND INDICATE YOU WANT TO SAVE THE CHANGES.

When the display indicates the value desired you can push the Menu/Execute switch to get to the next item:

```
G = +25           R
```

OR you can scroll to “R”, push the Menu/Execute switch to get to:

```
SAVE SETTINGS?   Y N
```

Selecting **Y** will save the new settings. Selecting **N** will revert to the previous settings.

Pushing the Menu/Execute switch then takes you to this:

```
F = 335.000
G = +25.0
```

Figure 2.5 gives the menu items and how to make changes.

2.5.5 Gain Changes

When you get to this menu note that the gain changes will be made as you make them but if you do not wish to save the changes you have made, scroll to “**R**” and push the Menu/Execute switch and select “**NO**” in the “**SAVE SETTINGS?**” window or **do not press the Menu/Execute switch**; simply do nothing for approximately 30 seconds, and the system will return to the normal operating mode.

To change the GAIN:

Push the Menu/Execute switch to get to the gain setting (See Figure 2.5 for the sequence of menu options):

```
G = +25           R
```

Pressing the Up/Down switch will change the gain in 1 or 10 dB steps depending on the cursor location:

```
G = +35           R
```

By using the horizontal rocker switch the cursor can be moved left or right. Pressing the Up/Down switch will toggle the display digit selected until you have the desired gain.

```
G = +35           R
```

NOTE: THE GAIN WILL BE CHANGED AS YOU ADJUST THE NUMBERS. HOWEVER, THE VALUE WILL NOT BE STORED UNTIL YOU INDICATE YES IN THE SAVE SETTINGS WINDOW.

When the display indicates the value desired you can push the Menu/Execute switch to get to the next item:

```
REMOTE  OFF       R
```

OR you can scroll to “**R**” and push the Menu/Execute switch to get to:

```
SAVE SETTINGS?   Y N
```

Selecting **Y** will save the new settings. Selecting **N** will revert to the previous settings. Pushing the Menu/Execute switch then takes you to this:

```
F = 335.000
G = +25.0
```

Figure 2.5 gives the menu items and how to make changes.

2.5.5 Alarm Indications

An alarm condition will occur if any local oscillator phase lock loop (PLL) comes out of lock. The Mute LED will light if you select Mute and the Remote LED will light when you select the Remote mode.

Power Up	ON POWER UP REV 1.00		
Normal Display	NORMAL DISPLAY F = 335.000 G = +25.0		PUSH BUTTON
Menu 1 Frequency	PUSHING MENU/EXECUTE SEQUENCE F = <u>4</u> 35.000 R	SCROLL <> SCROLL ⤴	PUSH BUTTON
Menu 2 Gain (0 to +50)	G = + <u>2</u> 5 R	SCROLL <> SCROLL ⤴	PUSH BUTTON
Menu 3 Select Non-Inverting or Inverting Spectrum	REMOTE <u>O</u> FF R	SCROLL <> SCROLL ⤴	PUSH BUTTON
Menu 4 Set Unit to Remote Operation	DNSPECTRUM <u>N</u> ON R	SCROLL <> SCROLL ⤴	PUSH BUTTON
Menu 5 Select Frequency Step Size	STEP = <u>1</u> KHZ R	SCROLL <> SCROLL ⤴	PUSH BUTTON
Menu 6 Select External 10 MHz Reference (option E)	EXT REF <u>O</u> FF R	SCROLL <> SCROLL ⤴	PUSH BUTTON
Menu 7 Set Remote Mode (option Q)	RS 485 <u>O</u> FF R	SCROLL <> SCROLL ⤴	PUSH BUTTON
Menu 8 Set RS-485 Address (option Q)	ADDRESS = <u>0</u> 0 R	SCROLL <> SCROLL ⤴	PUSH BUTTON
Save? When "R" is selected or at the end of the menu options	SAVE SETTINGS? <u>Y</u> N	SCROLL <>	PUSH BUTTON

FIGURE 2.5 Menu Display and Sequence



6170 Shiloh Road
Alpharetta, Georgia 30005

(770) 886-8005
FAX (770) 886-7964
Toll Free 888-900-5588

WEB www.crosstechnologies.com
E-MAIL info@crosstechnologies.com

Printed in USA