

# Instruction Manual

# Model 2016-1351 Downconverter

August 2010, Rev. A

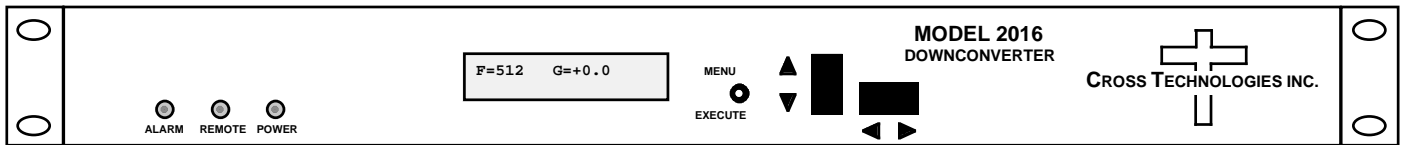

Data, drawings, and other material contained herein are proprietary to Cross Technologies, Inc., but may be reproduced or duplicated without the prior permission of Cross Technologies, Inc. for purposes of operating the equipment.

When ordering parts from Cross Technologies, Inc., be sure to include the equipment model number, equipment serial number, and a description of the part.



6170 Shiloh Road  
Alpharetta, Georgia 30005

Phone (770) 886-8005

FAX (770) 886-7964

Toll Free 888-900-5588

WEB [www.crosstechnologies.com](http://www.crosstechnologies.com)

E-MAIL [info@crosstechnologies.com](mailto:info@crosstechnologies.com)

# MODEL 2016-1351 Downconverter

<b><u>TABLE OF CONTENTS</u></b>	<b><u>PAGE</u></b>
<b>Warranty</b>	<b>2</b>
<b>1.0 General</b>	<b>3</b>
1.1 Equipment Description	<b>3</b>
1.2 Technical Characteristics	<b>4</b>
1.3 Monitor & Control Interface	<b>5</b>
<b>2.0 Installation</b>	<b>8</b>
2.1 Mechanical	<b>8</b>
2.2 Rear I/O's	<b>9</b>
2.3 Front Panel Controls, Indicators	<b>10</b>
2.4 Operation	<b>11</b>
2.5 Menu Settings	<b>12</b>
<b>4.0 Environmental Use Information</b>	<b>20</b>

**WARRANTY** - The following warranty applies to all Cross Technologies, Inc. products.

All Cross Technologies, Inc. products are warranted against defective materials and workmanship for a period of one year after shipment to customer. Cross Technologies, Inc.'s obligation under this warranty is limited to repairing or, at Cross Technologies, Inc.'s option, replacing parts, subassemblies, or entire assemblies. Cross Technologies, Inc. shall not be liable for any special, indirect, or consequential damages. This warranty does not cover parts or equipment which have been subject to misuse, negligence, or accident by the customer during use. All shipping costs for warranty repairs will be prepaid by the customer. There are not other warranties, express or implied, except as stated herein.

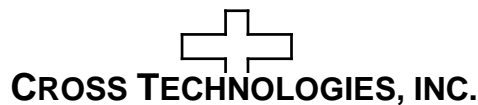

6170 Shiloh Road  
Alpharetta, Georgia 30005

(770) 886-8005  
FAX (770) 886-7964  
Toll Free 888-900-5588

WEB [www.crosstechnologies.com](http://www.crosstechnologies.com)  
E-MAIL [info@crosstechnologies.com](mailto:info@crosstechnologies.com)

# MODEL 2016-1351 Downconverter

## 1.0 General

### 1.1 Equipment Description

The 2016-1351 Downconverter converts 130 to 512 MHz to  $70 \pm 10$  MHz in 1 MHz steps with low group delay and flat frequency response. Synthesized local oscillators (LO) provide frequency selection. Multi-function push button switches select the input frequency, gain, and other parameters. Front panel LEDs provide indication of DC power, PLL alarm or Remote operation. Gain is adjustable manually (MGC) over a 0 to 10 dB range. The frequency and gain are remotely selectable. Parameter selection and frequency and gain settings appear on the LCD display. Connectors are BNC female for the RF, IF and optional external 10 MHz reference input and output (option -E). Other connector options are available. The 2016-1351 is powered by a 100-240  $\pm 10\%$  VAC power supply, and is contained in a 1 3/4" X 19" X 16" rack mount chassis.

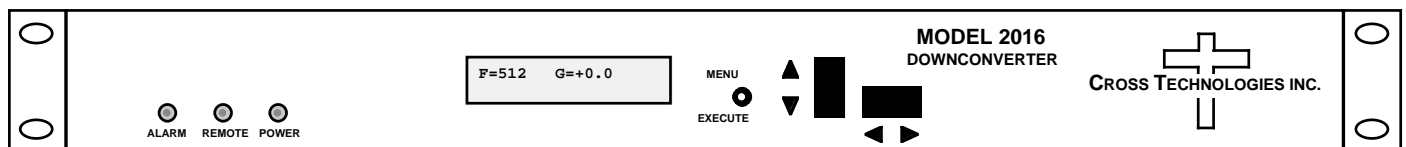

FRONT PANEL

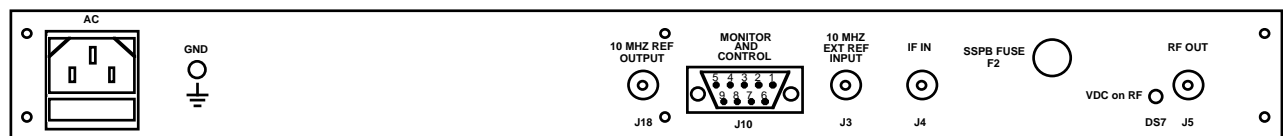

REAR PANEL

**FIGURE 1.1 Model 2016-1351 Front and Rear Panels**

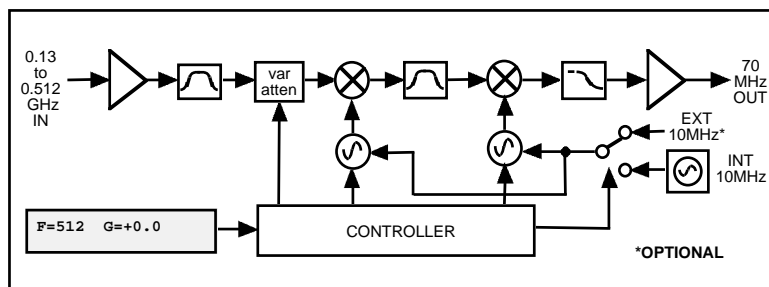

Block Diagram

**FIGURE 1.2 Model 2016-1351 Downconverter Block Diagram**

## 1.2 Technical Characteristics

**TABLE 1.0 2016-1351 Downconverter Specifications\***

### Input Characteristics (RF)

Impedance/Return Loss	50Ω /12 dB
Frequency	130 to 512 MHz
Noise Figure, max.	15 dB (max gain)
Input Level Range	-30 to -20 dBm
Input 1dB compression	-10 dBm

### Output Characteristics(IF)

Impedance/Return Loss	50Ω/18 dB
Frequency	70 ± 10 MHz
Output level Range	-30 to -20dBm
Output 1 dB compression	-10 dBmm

### Channel Characteristics

Gain range (adjustable)	0.0 to +10.0 dB, 1dB steps
Image Rejection	> 50 dB, min.
Frequency Response	±1.5 dB, 130 to 512 MHz ; ± 1.0 dB, 20 MHz BW
Spurious Response	< -50 dBc, in band
Group Delay, max	0.1 ns/MHz <sup>2</sup> parabolic; 0.15 ns/MHz linear; 1 ns ripple
Frequency Sense	Non-inverting

### Synthesizer Characteristics

Frequency Accuracy	± 1.0 ppm max. over temp (± 0.01 ppm option -H) internal reference
Frequency Step	1.0 MHz minimum
External 10 MHz level	+3 dBm, ± 3 dB, 50/75 ohms ( <b>option -E</b> )

Phase Noise @ Freq	100 Hz	1kHz	10kHz	100kHz	1MHz
dBC/Hz	-70	-70	-80	-90	-105

### Controls, Indicators

Freq/Gain Selection	Direct readout LCD; manual or remote selection
Power; Alarm; Remote	Green LED; Red LED; Yellow LED
Remote	RS232C, 9600 baud (RS422/485/opt.-Q, Ethernet/option-W8; -W18)

### Other

RF, IF Connectors	BNC, 50Ω (female), BNC,50Ω (female)
10MHz Connectors	BNC (female), 50Ω/75Ω (option E)
Alarm/Remote Connector	DB9 (female) - NO or NC contact closure on Alarm
Size	19 inch, 1RU standard chassis 1.75”high X 16.0” deep
Power	100-240 ±10% VAC, 47-63 Hz, 45 watts max

### Options

-E	External 10 MHz ref input & output
-H	High Stability (± 0.01 ppm) internal reference
-Q	RS-422/RS-485 Remote capability
-W8	Ethernet; with Web Browser
-W18	Ethernet; with Web Browser & SNMP
-W28	Ethernet; <i>Telenet</i>
-X	125 kHz step size
Connector Options	See TABLE 2.2

\*+10°C to +40°C; Specifications subject to change without notice

### 1.3 Monitor and Control Interface

#### A) Remote serial interface

**Protocol:** RS-232C, 9600 baud rate, no parity, 8 data bits, 1 start bit, and 1 stop bit.  
(RS-232C, RS-422, or RS-485 - **option -Q**)

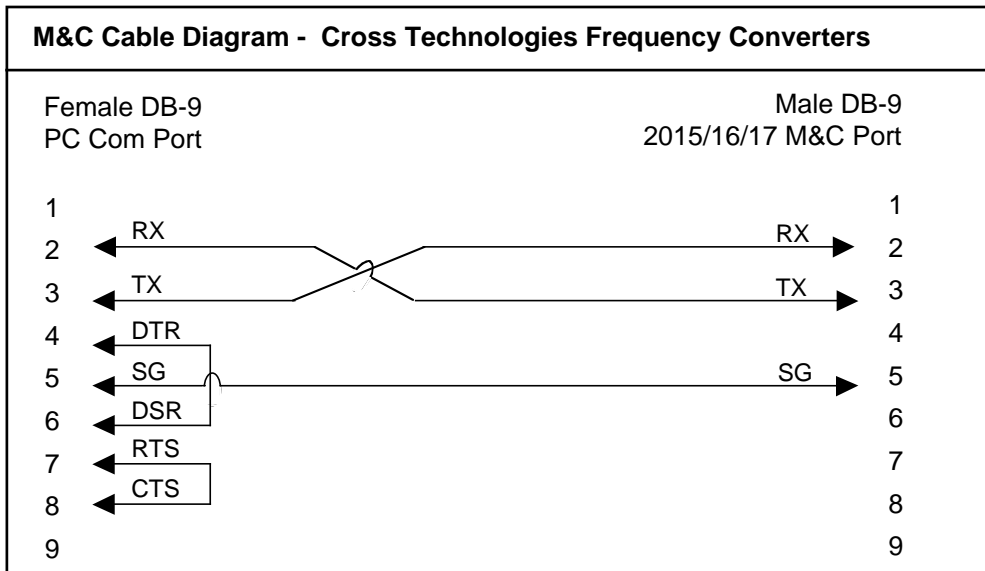

**Connector:** Rear panel, DB-9 male

J10 Pinouts (RS-232C/422/485)	
Pin	Function
1	Rx-
2	Rx+ (RS-232C)
3	Tx+ (RS-232C)
4	Tx-
5	GND
6	Alarm Relay: Common
7	Alarm Relay: Normally Open
8	Not Used
9	Alarm Relay: Normally Closed

**B) Status Requests** Table 1.1 lists the status requests for the 2016-1351 and briefly describes them.

\* PLEASE NOTE: The two character {aa}(00-31) prefix, in the table below, should be used ONLY when RS-485, (OPTION-Q), is selected.

<b>TABLE 1.1 2016-1351 Status Requests</b>		
<b>Command</b>	<b>Syntax *</b>	<b>Description</b>
Command Status	{aaS1}	Returns {aaS1bbbbccddAM} where:
		• bbbb = Rx frequency
		• cc = Rx gain
		• A = 0 - summary alarm
10MHZ Reference Status	{aaS2}	Returns {aaS2E} where:
<b>(option -E only)</b>		• E = Ext 10MHz Status (1 = on, 0 = off)

**C) Commands** Table 1.2 lists the commands for the 2016-1351 and briefly describes them. After a command is sent the 2016-1351 sends a return “>” indicating the command has been received and executed.

**General Command Format** - The general command format is {aaCND...}, where:

- { = start byte
- aa = address (**RS-485 only option -Q**)
- C = 1 character, either C (command) or S (status)
- N = 1 character command or status request
- D = 1 character or more of data (depends on command)
- } = stop byte

\* PLEASE NOTE: The two character {aa}(00-31) prefix, in the table below, should be used ONLY when RS-485, (OPTION-Q), is selected.

<b>Table 1.2 2016-1351 Commands</b>		
<b>Command</b>	<b>Syntax*</b>	<b>Description</b>
Set Receiver Frequency	{aaC2xxx}	where: <ul style="list-style-type: none"> <li>• xxx = 3 characters</li> <li>• Range: 130 to 512 MHz</li> </ul>
Set Receiver Gain	{aaC4xx}	where: <ul style="list-style-type: none"> <li>• xx = 2 characters (0 to 10dB)</li> <li>• Range: 0 to +10 dB</li> </ul>
Enable External 10MHz (option -E only)	{aaCEx}	where x = <ul style="list-style-type: none"> <li>• 0 to disable External 10MHz ref signal</li> <li>• 1 to enable External 10MHz ref signal</li> </ul>
Enable Remote	#	Just # sign
Disable Remote	{aaCRO}	{CR and zero}

## 2.0 Installation

**2.1 Mechanical** - The 2016-1351 consists of one RF/Controller PCB housed in a 1 RU (1.75 inch high by 16 inch deep) chassis. A switching,  $\pm 12$ ,  $+24$ ,  $+5$  VDC power supply provides power for the assemblies. The 2016-1351 can be secured to a rack using the 4 holes on the front panel. Figure 2.0 shows how the 2016-1351 is assembled.

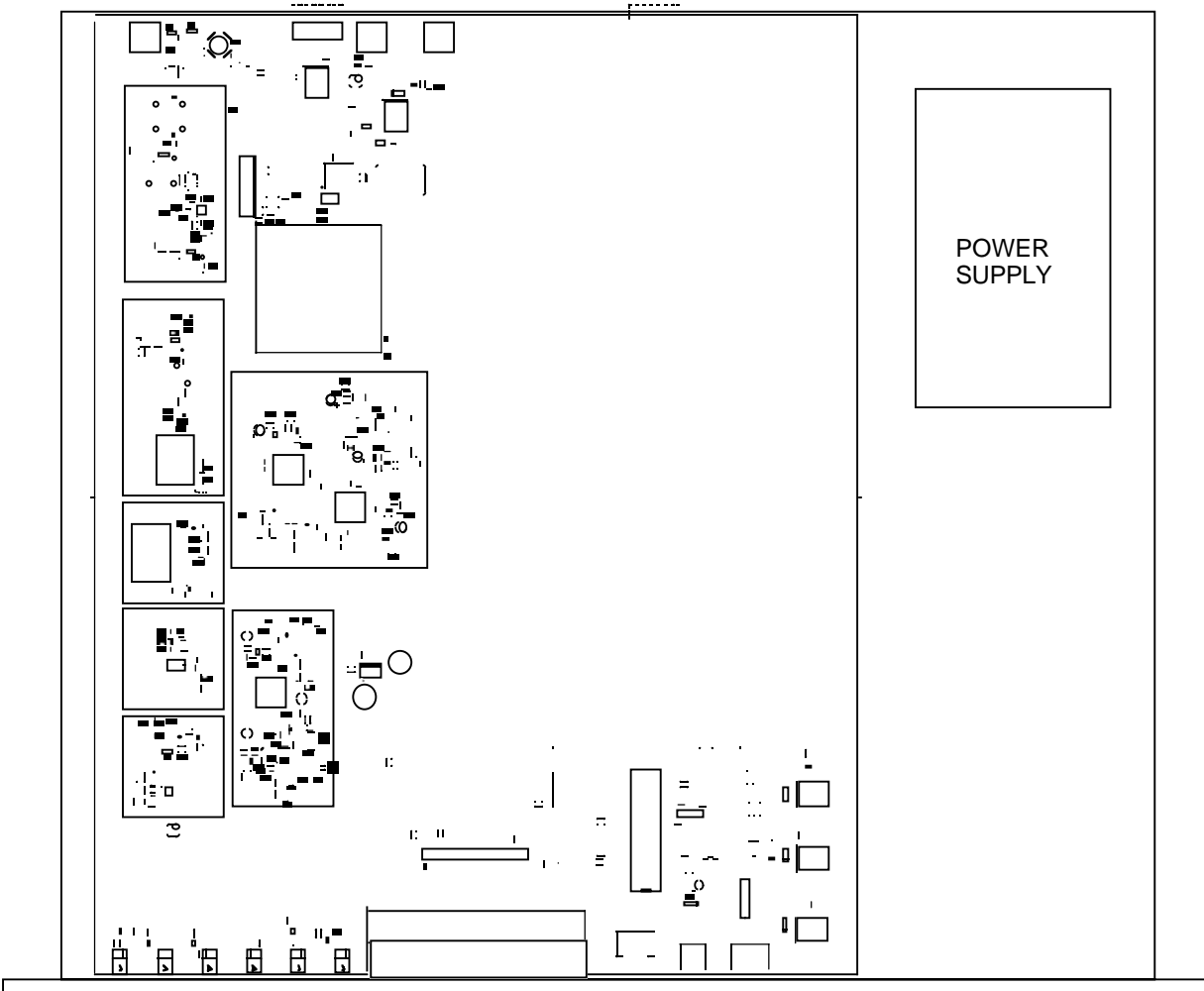

**FIGURE 2.0 2016-1351 Mechanical Assembly**



## 2.2 Rear Panel Input/Output Signals - Figure 2.1 shows the input and output connectors on the rear panel.

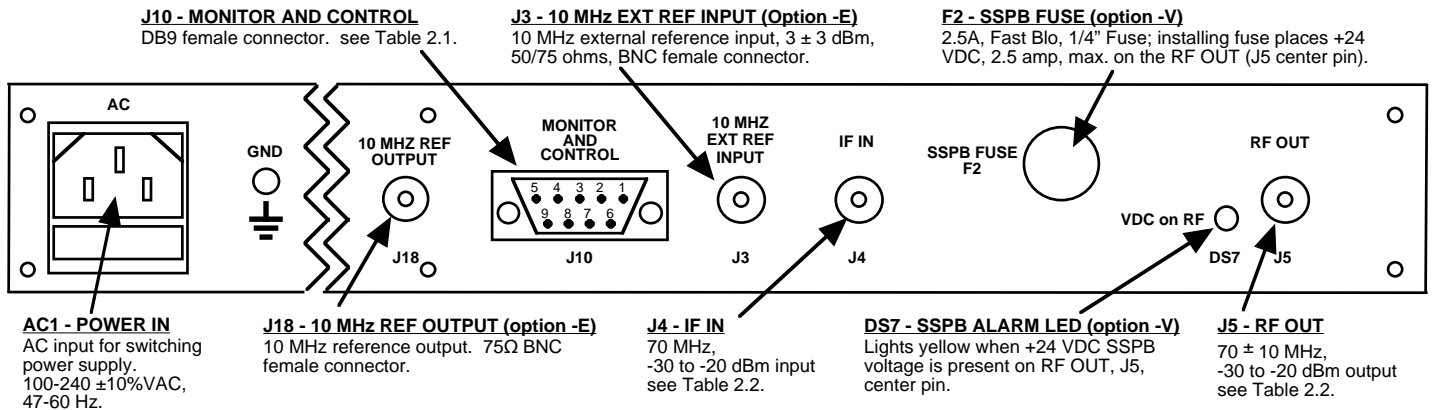

**FIGURE 2.1 2016-1351 Rear Panel I/O's**

Pin	Function
1	Rx-
2	Rx+ (RS-232C)
3	Tx+ (RS-232C)
4	Tx-
5	GND
6	Alarm Relay: Common
7	Alarm Relay: Normally Open
8	Not Used
9	Alarm Relay: Normally Closed

### \*Remote Serial Interface

Interface: DB-9 Male

Protocol: RS-232C (RS-232C/422/485 **option -Q**), 9600 baud rate, no parity, 8 data bits, 1 start bit, 1 stop bit.

Option	IF	RF
STD	BNC, 75Ω	Type F, 75Ω
-B	BNC, 75Ω	BNC, 75Ω
-C	BNC, 75Ω	BNC, 50Ω
-K	BNC, 50Ω	BNC, 75Ω
-M	BNC, 50Ω	Type N, 50Ω
-N	BNC, 75Ω	Type N, 50Ω
-S	BNC, 50Ω	SMA, 50Ω
-SS	SMA, 50Ω	SMA, 50Ω
-W26	RF/IF Connectors on the front panel	

**2.3 Front Panel Controls and Indicators** - The following are the front panel controls and indicators.

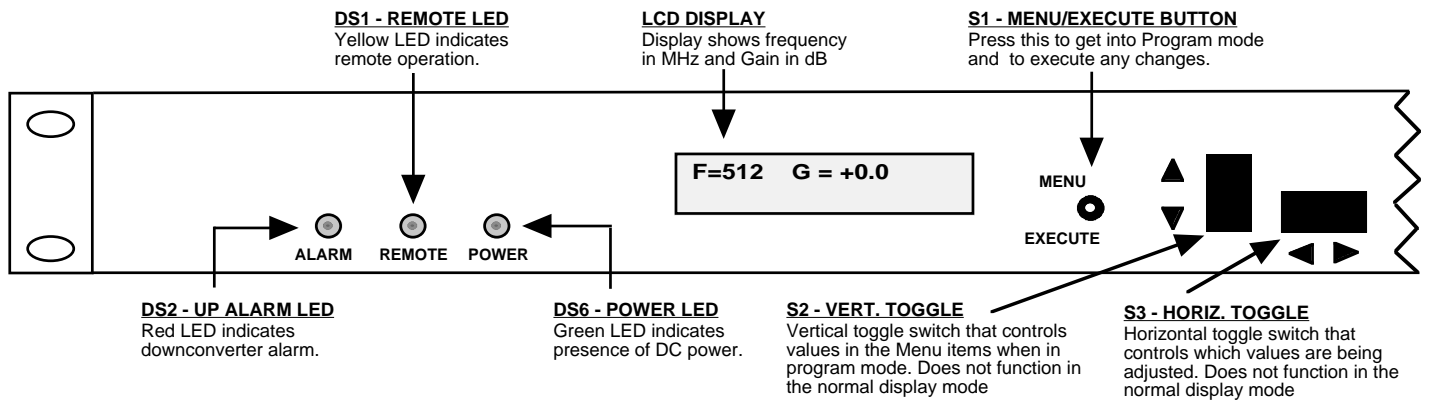
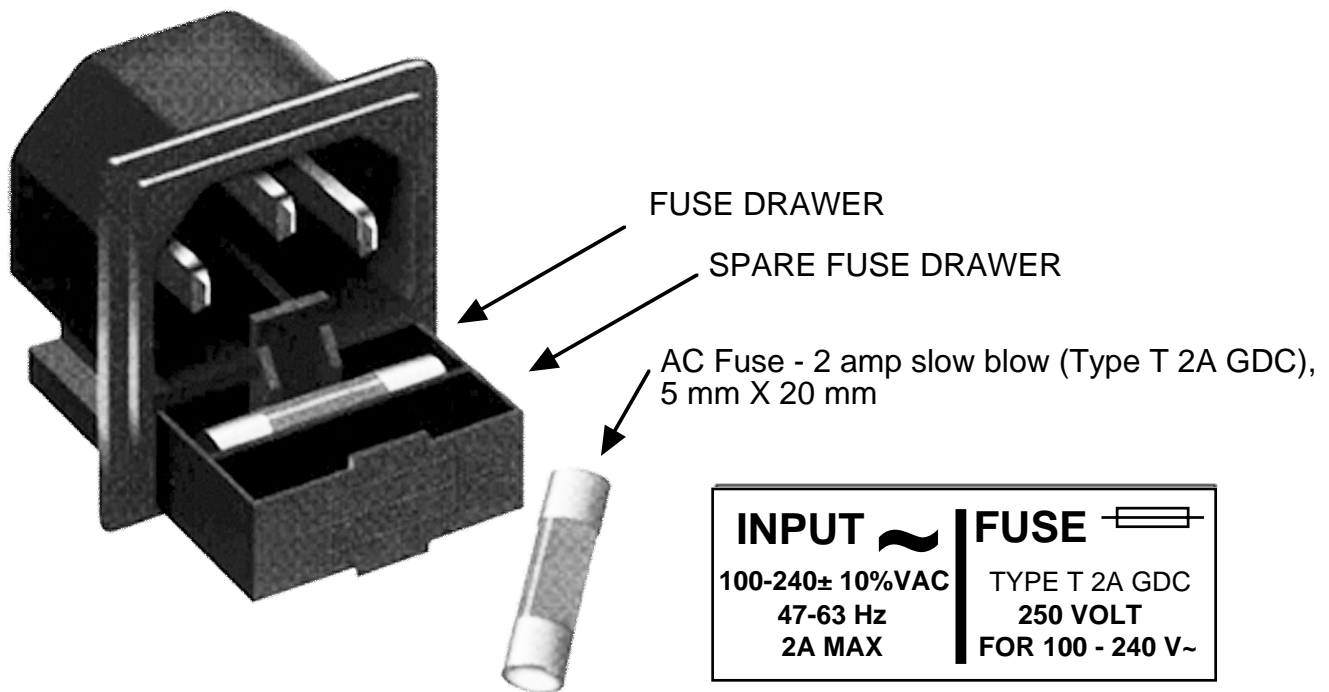

**FIGURE 2.2** 2016-1351 Front Panel Controls and Indicators

## 2.4 Installation / Operation

### 2.4.1 Installing and Operating the 2016-1351, Downconverter Section

1. Connect a -30 to -20 dBm signal to IF In, J4 (Figure 2.1).
2. Connect the RF OUT, J5, to the external equipment.
3. Connect 100-240  $\pm$ 10% VAC, 47 - 63 Hz to AC1 on the back panel.
4. Set the desired output frequency (See Section 2.5 Menu Settings).
5. Set the input level (See Section 2.5 Menu Settings).
6. Set the gain for 0.0 to +10 dB. Make sure the output stays within -30 to -20 dBm with the gain selected and the input level provided. The firmware will prevent setting gain and input level outside this range. (See Section 2.5 Menu Settings).
7. Be sure DS6 (green, DC Power) is on and DS2 (red, Alarm) is off (Figure 2.2).
8. Option -V only - To insert SSPB +24 VDC on the RF center pin install 2.5A fast blo fuse in F2 and check that DS7 lights yellow (Figure 2.1).
9. **AC Fuse** - The fuse is a 5 mm X 20 mm, 2 amp slow blow (Type T) and is inserted in the far slot in the drawer below the AC input as shown in Figure 2.3. There is a spare fuse in the near slot. If a fuse continues to open, the power supply is most likely defective.



**FIGURE 2.3 Fuse Location and Spare Fuse**

## 2.5 Menu Settings

**2.5.1 Functions** - This section describes operation of the front panel controls. There are three operator switches, the LCD display and alarm indicator LEDs. All functions for the equipment are controlled by these components. The functions are (see Figure 2.4):

### Power Up

### Normal Display

- Menu 1**      Frequency in MHz
- Menu 2**      Gain (0.0 to +10.0 dB, 1dB steps (0.1dB steps, option -Z))
- Menu 3**      Set Unit to Remote Operation
- Menu 4**      Select External 10 MHz Ref (option -E)
- Menu 5**      Set Remote mode (option -Q) (option W8, W18)
- Menu 6**      Set RS-485 address (option -Q)
- Menu 7**      View PCB Temperature (option -T)

**Save Menu** When go to end

Alarm indications appear on the LEDs (see figure 2.2).

All program changes must start with the operation of the Menu/Execute switch and must also end with the operation of the Menu/Execute switch verified by the “Save Settings?” Menu. If this sequence is not followed, none of the changes will take effect. If programming is initiated and no operator action takes place for approximately 12 seconds (before the final press of the Menu/Execute switch) the display will revert to its previous status and you will need to start over.

## 2.5.2. Power On Settings

**NOTE: THE LAST STATUS OF A UNIT IS RETAINED EVEN WHEN POWER IS REMOVED. WHEN POWER IS RESTORED, THE UNIT WILL RETURN TO IT'S PREVIOUS SETTINGS.**

When power is first applied, the LCD display goes through three steps.

1. The LCD goes black to show all segments are functioning.
2. The software version will be displayed.



REV 1.00

3. The present frequency and gain of the Downconverter is shown.

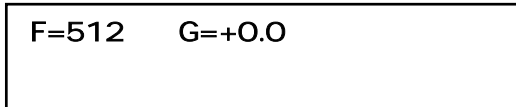

F=512 G=+0.0

The unit is now operational and ready for any changes the operator may desire.

## 2.5.3 Control Switches

1. Menu/Execute - Any change to the programming of the unit must be initiated by pressing the Menu/Execute switch and completed by pressing the Menu/Execute switch.
2. Horizontal Switch - This switch is mounted so its movement is horizontal and moves the cursor left or right.
3. Vertical Switch - This switch is mounted so its movement is vertical and has two functions:
  - a. For other functions such Mute on/off, the vertical switch will alternately turn the function on or off regardless of the direction operated.
  - b. During frequency, gain changes, the vertical movement will raise or lower the number in the direction of the arrows.

## 2.5.4 Frequency Changes

At any time during the modification process, if you have made a mistake and do not wish to save the changes you have made, **do not press the Menu/Execute switch**; simply do nothing for approximately 12 seconds, and the system will return to the normal operating mode or scroll to “**R**” and push the Menu/Execute switch and select “**NO**” in the “**SAVE SETTINGS?**” window.

To change the FREQUENCY:

Operate the Menu/Execute switch until you get to the menu item you want to change see Figure 2.4 for the sequence of menu options. The following display is for changing the Downconverter frequency:

F = <u>3</u> 12	R
-----------------	---

Pressing the Up/Down switch down will toggle the display to:

F = <u>4</u> 12	R
-----------------	---

By using the horizontal rocker switch the cursor can be moved left or right.

F = 4 <u>1</u> 2	R
------------------	---

**NOTE: CHANGES DO NOT TAKE PLACE ON FREQUENCY UNTIL YOU GO TO THE SAVE MENU AND INDICATE YOU WANT TO SAVE THE CHANGES. THE CARRIER IS MUTED WHEN FREQUENCY IS CHANGED.**

When the display indicates the value desired you can push the Menu/Execute switch to the next item:

UP INLVL = - <u>1</u> 0	R
-------------------------	---

OR you can scroll to “R”, push the Menu/Execute switch to get to:

S A V E S E T T I N G S ? <u>Y</u> N
--------------------------------------

Selecting **Y** will save the new settings. Selecting **N** will revert to the previous settings.

Pushing the Menu/Execute switch then takes you to the :

F=512    G=+0.0
-----------------

Figure 2.4 gives the menu items and how to make changes.



## 2.5.5 Alarm Indications

An alarm condition will occur if any local oscillator phase lock loop (PLL) comes out of lock. The Mute LED will light if you select Mute and the Remote LED will light when you select the Remote mode.

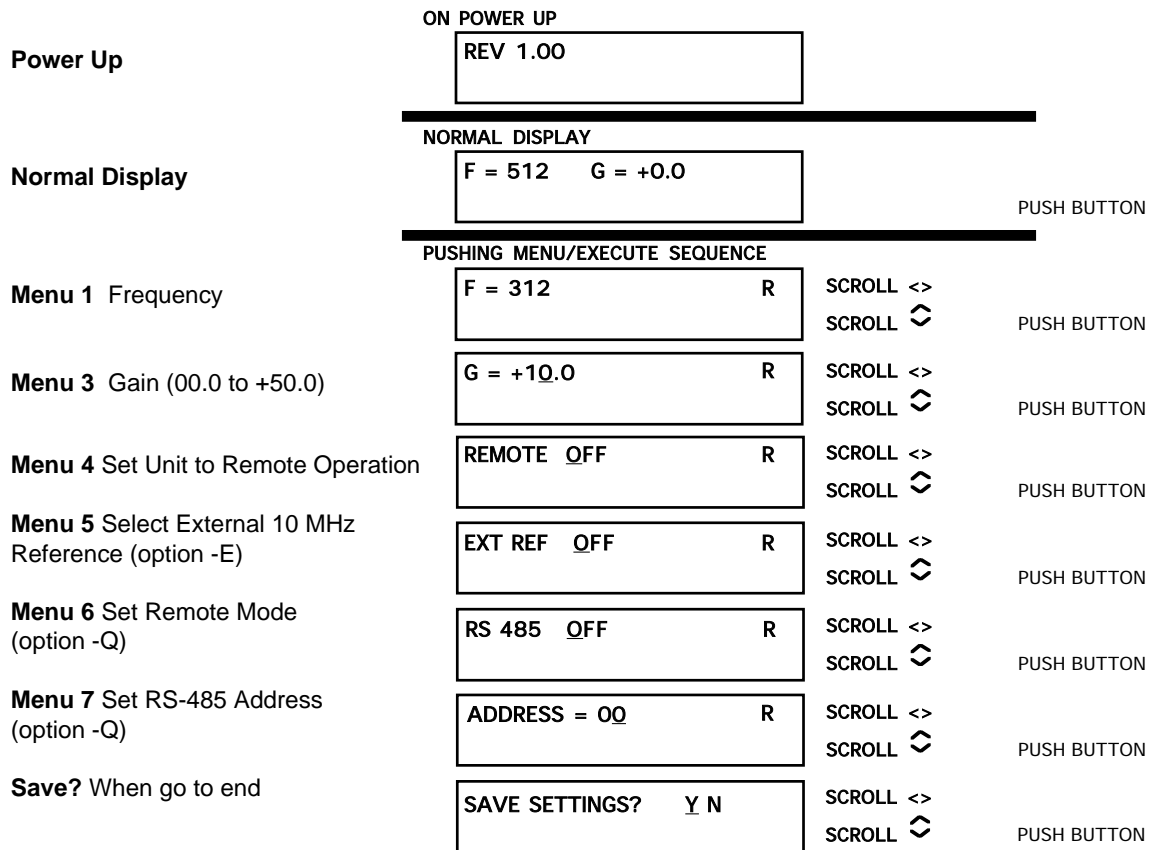

**FIGURE 2.4 Menu Display and Sequences**



#### 4.0 Environmental Use Information

- A. **Rack-Mounting** - To mount this equipment in a rack, please refer to the installation instructions located in the user manual furnished by the manufacturer of your equipment rack.
- B. **Mechanical Loading** - Mounting of equipment in a rack should be such that a hazardous condition does not exist due to uneven weight distribution.
- C. **Elevated Operating Ambient Temperature** - If installed in a closed or multi-unit rack assembly, the operating ambient temperature of the rack may be greater than room ambient temperature. Therefore, consideration should be given to  $T_{mra}$ .
- D. **Reduced Air Flow** - Installation of the equipment in a rack should be such that the amount of air flow required for safe operation of the equipment is not compromised. Additional space between unit may be required.
- E. **Circuit Overloading** - Consideration should be given to the connection of the equipment to the supply circuit and the effect that overloading of circuits could have on over current protection and supply wiring. Appropriate consideration of equipment name plate rating should be used when addressing this concern.
- F. **Reliable Earthing** - Reliable earthing of rack-mounted equipment should be maintained. Particular attention should be given to supply connections other than direct connection to the Branch (use of power strips).
- G. **Top Cover** - There are no serviceable parts inside the product so, the Top Cover should not be removed. If the Top Cover is removed the ground strap and associated screw **MUST BE REINSTALLED** prior to Top Cover screw replacement. **FAILURE TO DO** this may cause **INGRESS** and/or **EGRESS** emission problems.



6170 Shiloh Road  
Alpharetta, Georgia 30005

Phone (770) 886-8005

FAX (770) 886-7964

Toll Free 888-900-5588

WEB [www.crosstechnologies.com](http://www.crosstechnologies.com)

E-MAIL [info@crosstechnologies.com](mailto:info@crosstechnologies.com)

Printed in USA