

Instruction Manual

Model 1584-29 RF Splitter

May 2009 Rev B

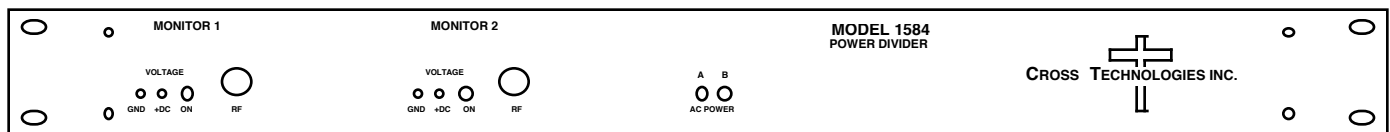

Data, drawings, and other material contained herein are proprietary to Cross Technologies, Inc., but may be reproduced or duplicated without the prior permission of Cross Technologies, Inc. for purposes of operating the equipment.

When ordering parts from Cross Technologies, Inc., be sure to include the equipment model number, equipment serial number, and a description of the part.



6170 Shiloh Road
Alpharetta, Georgia 30005

(770) 886-8005
FAX (770) 886-7964
Toll Free 888-900-5588

WEB www.crosstechnologies.com
E-MAIL info@crosstechnologies.com

INSTRUCTION MANUAL
MODEL 1584-29 RF Splitter

<u>TABLE OF CONTENTS</u>	<u>PAGE</u>
Warranty	2
1.0 General	3
1.1 Equipment Description	3
1.2 Technical Characteristics	4
1.3 Environmental Use Information	5
2.0 Installation	6
2.1 Mechanical	6
2.2 Rear Panel Input/Output Connectors	7
2.3 Front Panel Monitors and Indicators	7
2.4 Operation	8

WARRANTY - The following warranty applies to all Cross Technologies, Inc. products.

All Cross Technologies, Inc. products are warranted against defective materials and workmanship for a period of one year after shipment to customer. Cross Technologies, Inc.'s obligation under this warranty is limited to repairing or, at Cross Technologies, Inc.'s option, replacing parts, subassemblies, or entire assemblies. Cross Technologies, Inc. shall not be liable for any special, indirect, or consequential damages. This warranty does not cover parts or equipment which have been subject to misuse, negligence, or accident by the customer during use. All shipping costs for warranty repairs will be prepaid by the customer. There are not other warranties, express or implied, except as stated herein.



6170 Shiloh Road
Alpharetta, Georgia 30005

(770) 886-8005
FAX (770) 886-7964
Toll Free 888-900-5588

WEB www.crosstechnologies.com
E-MAIL info@crosstechnologies.com

MODEL 1584-29 RF Splitter

1.0 General

1.1 Equipment Description - The Model 1584-29 is two, nine way, 0.95 - 2 GHz, 0 dB gain splitters in a 1 Rack Unit chassis with redundant 100-240 \pm 10% VAC power supplies. Each splitter provides fused DC power insertion on the input connector center pin, surge protection, and excellent RF characteristics. Each splitter has a monitor connector on the front panel and eight outputs on the back panel. Two individual 90-260 VAC input power supplies provide a diode OR'd +22 VDC voltage for internal amplifiers and for DC to power external amplifiers (often Low Noise Block converters or LNBS) through DC power inserters. Each LNB power line is separately fused. A surge suppressor on each splitter input protects against high voltage transients. All splitter outputs are AC coupled so no DC appears on their center conductors. On the front panel, green LEDs indicate presence of +22 VDC at each LNB power supply output and DC voltage test points allow monitoring this voltage with a voltmeter. Presence of power from the +24 VDC power supplies is shown by the AC Power A and B green LEDs.

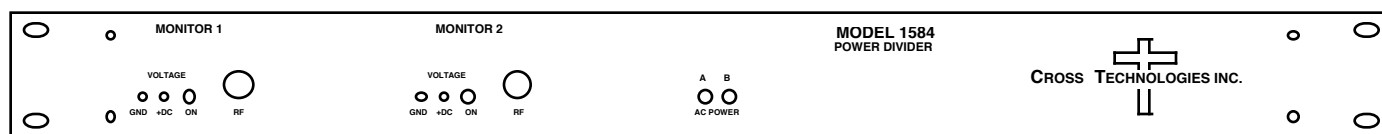

FRONT PANEL

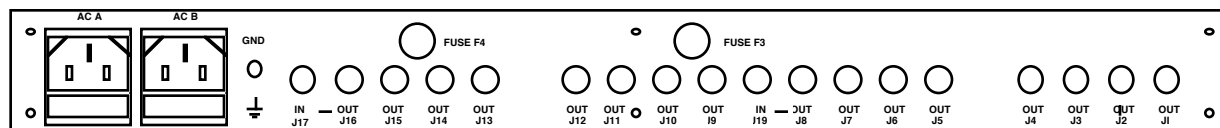

REAR PANEL

FIGURE 1.1 MODEL 1584-29 FRONT AND REAR PANELS

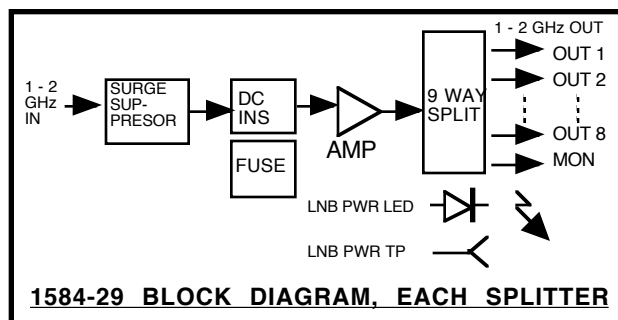

FIGURE 1.2 MODEL 1584-29 RF SPLITTER BLOCK DIAGRAM

1.2 Technical Characteristics

TABLE 1.0 1584-29 RF SPLITTER SPECIFICATIONS

<u>Characteristics</u>	<u>Specifications*</u>
Input Characteristics	
Input Impedance/RL	75 Ω /10dB, min, 0.95-2.05 GHz; 14dB, typ, 0.95-1.75 GHz
Input Level	-20 dBm total maximum
Output Characteristics	
Impedance/RL	75 Ω /10dB, min, 0.95-2.05 GHz; 14 dB, typ, 0.95-1.75 GHz
In-Band Characteristics	
Gain	+0 dB \pm 1.0 dB
Frequency Response	\pm 1.0 dB, 0.95 - 1.75 GHz; \pm 0.5 dB, any 20 MHz incr. +1, -3 dB, 1.75 - 2 GHz; \pm 0.7 dB, any 20 MHz incr
Port to Port Isolation	> 18 dB, min., 20 dB typ.
Coupler to Coupler Isol.	> 35 dB, min., 40 dB typ
Indicators	
Power	Green LED indicates DC voltage prior to diode OR and to amplifiers
Other	
LNB DC voltage	22 \pm 2 VDC
Output Amplifier current	300 ma, max., each
Surge Suppressor	SiDACTOR
RF connectors	Type F , female
Fuses - AC	5mm, 2 amp, fast blo
Fuses - LNB Voltage	1/4 “, 1 amp, fast blo
AC Power	Redundant power supplies, 100-240 \pm 10% VAC, 50 -60 Hz, 30 watts max
Mechanical	19 inch standard chassis 1.75”high X 12” deep

*+10 to +40 degrees C; 2000 meters max elevation; 80% max humidity; Pollution Degree 2; Specifications subject to change without notice.

1.3 Environmental Use Information

- A. **Rack-Mounting** - To mount this equipment in a rack, please refer to the installation instructions located in the user manual furnished by the manufacturer of your equipment rack.
- B. **Mechanical Loading** - Mounting of equipment in a rack should be such that a hazardous condition does not exist due to uneven weight distribution.
- C. **Elevated Operating Ambient Temperature** - If installed in a closed or multi-unit rack assembly, the operating ambient temperature of the rack may be greater than room ambient temperature. Therefore, consideration should be given to Tmra.
- D. **Reduced Air Flow** - Installation of the equipment in a rack should be such that the amount of air flow required for safe operation of the equipment is not compromised. Additional space between unit may be required.
- E. **Circuit Overloading** - Consideration should be given to the connection of the equipment to the supply circuit and the effect that overloading of circuits could have on over current protection and supply wiring. Appropriate consideration of equipment name plate rating should be used, when addressing this concern.
- F. **Reliable Earthing** - Reliable earthing of rack-mounted equipment should be maintained. Particular attention should be given to supply connections other than direct connection to the Branch (use of power strips).
- G. **Top Cover** - There are no serviceable parts inside the product so, the Top Cover should not be removed. If the Top Cover is removed the ground strap and associated screw **MUST BE REINSTALLED** prior to Top Cover screw replacement. **FAILURE TO DO** this may cause **INGRESS** and/or **EGRESS** emission problems.

2.0 Installation

2.1 Mechanical - The 1584-29 consists of one RF printed circuit board (PCB) housed in a 1 RU (1 3/4 inch high) by 12 inch deep chassis. Redundant, switching, +24 VDC power supplies with the DC output diode OR'd provide redundant power for the internal and external amplifiers and LEDs. Connectors are type F, female for the RF connections. The 1584-29 can be secured to a rack using the 4 holes on the front panel. Figure 2.1 shows how the 1584-29 is assembled. J27 and J25 connect DC Power to the fuses as shown and J30 and J29 connect the DC voltage from the power supplies to the PCB as shown.

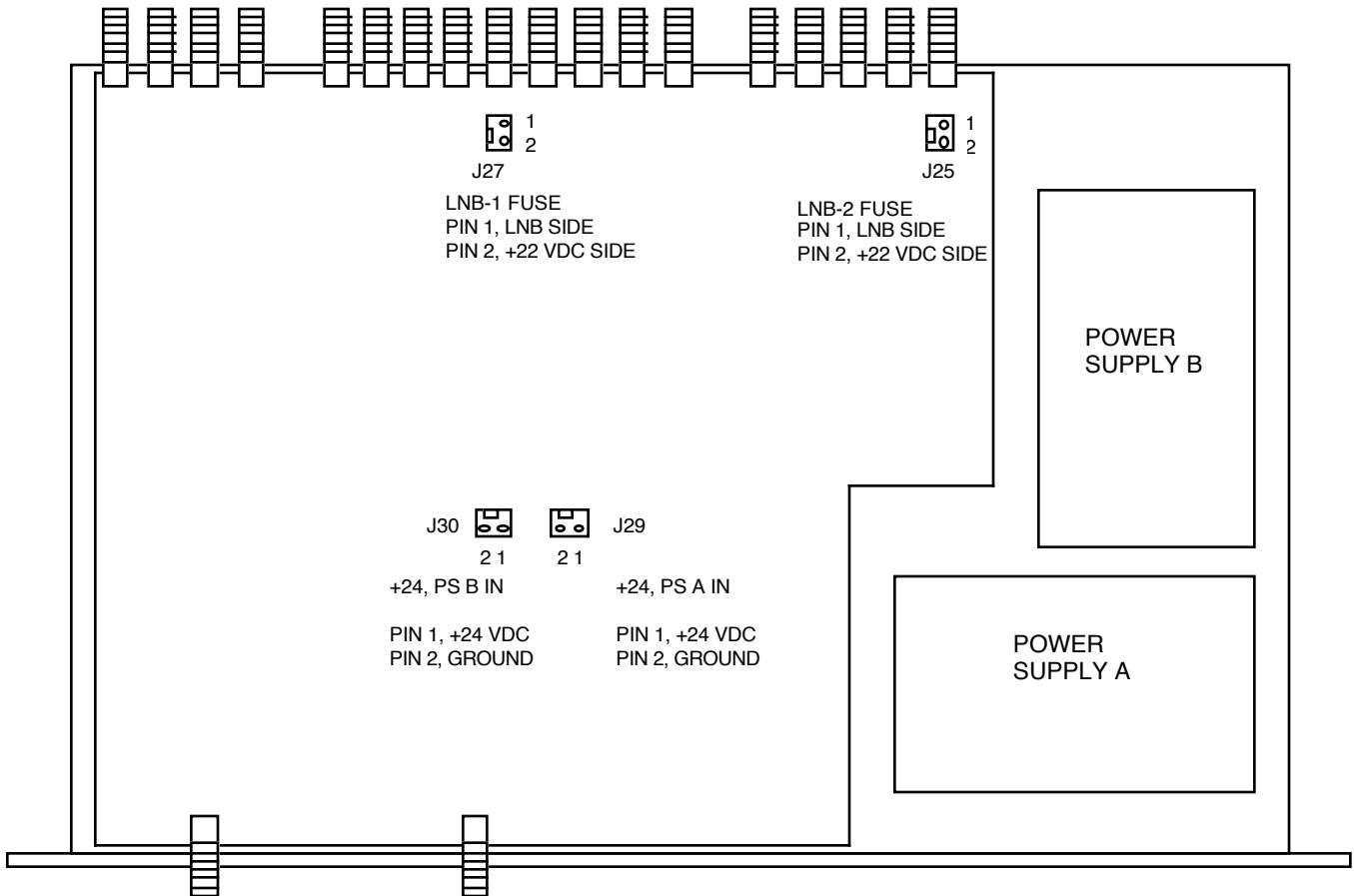

FIGURE 2.0 1584-29 MECHANICAL ASSEMBLY

2.2 Rear Panel Input/Output Connectors -

The input and output connectors on the rear panel are shown in Figure 2.1.

CAUTION! IF FUSES ARE INSTALLED IN THE Fuse 3 OR Fuse 4 HOLDERS, +22 VDC WILL APPEAR ON THE CORRESPONDING SPLITTER INPUT CONNECTOR CENTER PINS.

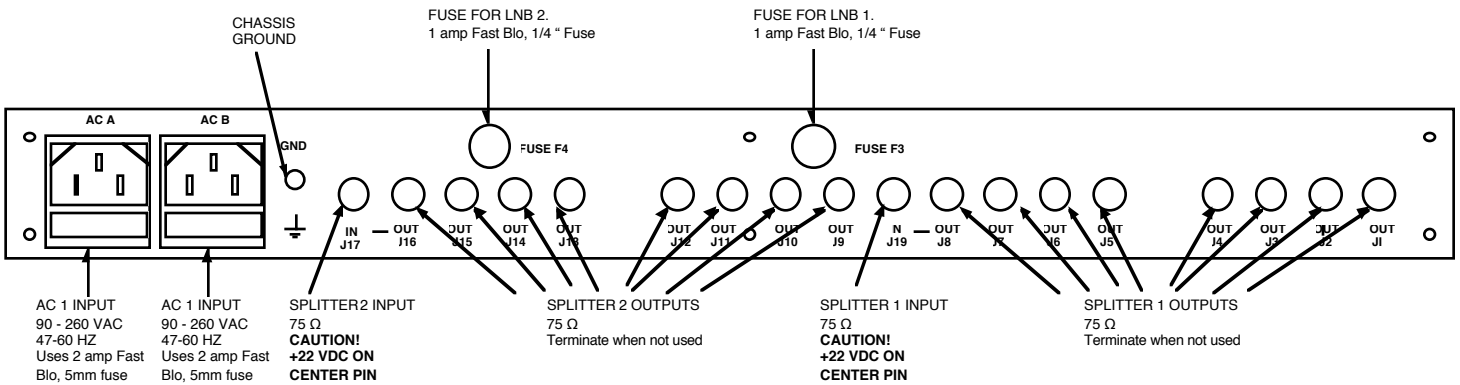

FIGURE 2.1 1584-29 REAR PANEL

2.3 Front Panel Monitors and Indicators -

Figure 2.2 shows the front panel monitors and indicators.

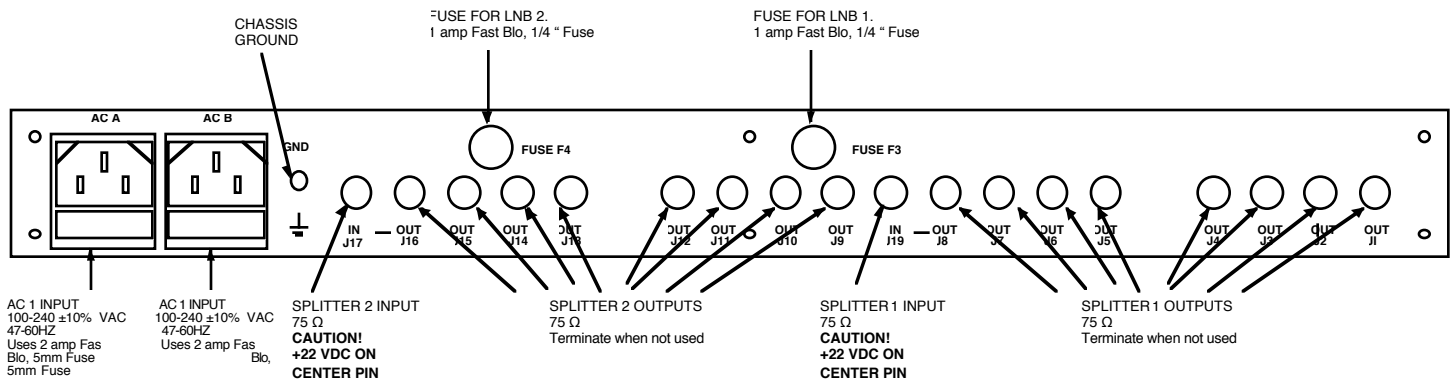

FIGURE 2.2 1584-29 FRONT PANEL

2.4 Operation -

- 1.) Connect RF cables to the 1584-29 (See Section 2.2).
- 2.) IF DC VOLTAGE IS REQUIRED ON THE SPLITTER RF INPUT CENTER CONDUCTOR, install 1/4", 1 amp fast blo fuses in Fuse 3 and/or Fuse 4 holders.

CAUTION! IF FUSES ARE INSTALLED IN THE Fuse 3 OR Fuse 4 HOLDERS, +22 VDC WILL APPEAR ON THE CORRESPONDING SPLITTER INPUT CONNECTOR CENTER PINS.

- 3.) Connect 100-240 \pm 10% VAC, 47 - 63 Hz to AC A and AC B on the back panel and observe A and B LEDs are lit on the front panel.
- 4.) Monitor RF signals on the front panel monitors and DC voltage to the external amplifiers (Front panel Green ON LEDs should be lit if LNB fuses are installed in the rear panel fuse holders) to insure proper signals and voltages.

NOTE: FOR OPTIMUM PERFORMANCE, THE MONITOR PORT AND SPLITTER PORTS SHOULD BE TERMINATED WITH 75 OHM TYPE F TERMINATIONS WHEN NOT USED.

5.) **AC Fuse** - The fuse is a 5mm, 2 amp fast blo and is inserted in the far slot in the drawer below the AC input as shown in Figure 2.6. There is a spare fuse in the near slot. If a fuse continues to open, the power supply is most likely defective. Note that each power supply module within the chassis also has a fuse but failure of this fuse indicates the power supply may be defective.

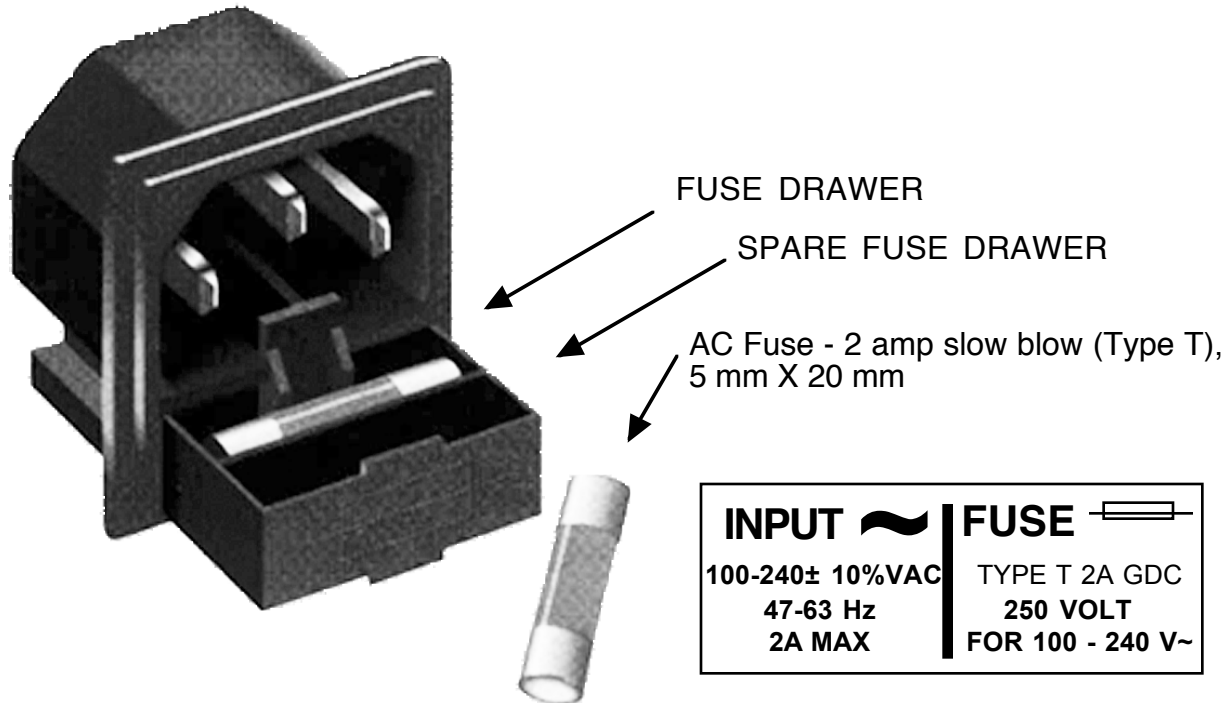

FIGURE 2.6 FUSE LOCATION AND SPARE FUSE



6170 Shiloh Road
Alpharetta, Georgia 30005

(770) 886-8005
FAX (770) 886-7964
Toll Free 888-900-5588

WEB www.crosstechnologies.com
E-MAIL info@crosstechnologies.com