

# Instruction Manual

# Model 1584-116 RF Splitter

December 2010, Rev. F

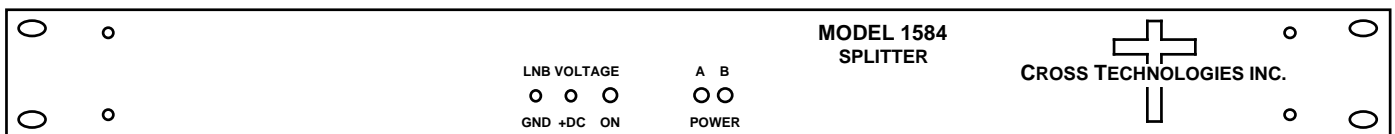

Data, drawings, and other material contained herein are proprietary to Cross Technologies, Inc., but may be reproduced or duplicated without the prior permission of Cross Technologies, Inc. for purposes of operating the equipment.

When ordering parts from Cross Technologies, Inc., be sure to include the equipment model number, equipment serial number, and a description of the part.



6170 Shiloh Road  
Alpharetta, Georgia 30005

(770) 886-8005  
FAX (770) 886-7964  
Toll Free 888-900-5588

WEB [www.crosstechnologies.com](http://www.crosstechnologies.com)  
E-MAIL [info@crosstechnologies.com](mailto:info@crosstechnologies.com)

# INSTRUCTION MANUAL

## MODEL 1584-116, 16-Way Splitter

<u>TABLE OF CONTENTS</u>	<u>PAGE</u>
Warranty	2
<b>1.0 General</b>	<b>3</b>
1.1 Equipment Description	3
1.2 Technical Characteristics	4
<b>2.0 Installation</b>	<b>5</b>
2.1 Mechanical	5
2.2 Rear Panel Input/Output Connectors	6
2.3 Front Panel Monitors and Indicators	6
2.4 Operation	7
2.5 Environmental Use Information	8

**WARRANTY** - The following warranty applies to all Cross Technologies, Inc. products.

All Cross Technologies, Inc. products are warranted against defective materials and workmanship for a period of one year after shipment to customer. Cross Technologies, Inc.'s obligation under this warranty is limited to repairing or, at Cross Technologies, Inc.'s option, replacing parts, subassemblies, or entire assemblies. Cross Technologies, Inc. shall not be liable for any special, indirect, or consequential damages. This warranty does not cover parts or equipment which have been subject to misuse, negligence, or accident by the customer during use. All shipping costs for warranty repairs will be prepaid by the customer. There are no other warranties, express or implied, except as stated herein.



6170 Shiloh Road  
Alpharetta, Georgia 30005

(770) 886-8005  
FAX (770) 886-7964  
Toll Free 888-900-5588

WEB [www.crosstechnologies.com](http://www.crosstechnologies.com)  
E-MAIL [info@crosstechnologies.com](mailto:info@crosstechnologies.com)

# MODEL 1584-116 Splitter

## 1.0 General

### 1.1 Equipment Description

The Model 1584-116 is one sixteen-way, 0.95 - 2.05 GHz, 0 dB gain splitter in a 1RU rack mount chassis with redundant 100-240 ± 10% VAC power supplies. The splitter provides fused LNB DC power insertion and surge protection on the RF input, and provides excellent RF characteristics. The splitter has sixteen outputs on the back panel, and fused LNB power can be inserted on the input. Two individual 100-240 ± 10% VAC input power supplies provide diode OR'd redundant power to the unit. The LNB power line is separately fused. A surge suppressor on the splitter input protects against high voltage transients. On the front panel, two green LED's indicate the presence of DC voltage from each of the two power supplies\*, and another green LED indicates LNB power insertion. Two test points are also provided on the front panel to monitor the LNB voltage. (NOTE: The LNB Power Insertion feature is NOT available on 1584-116S model).

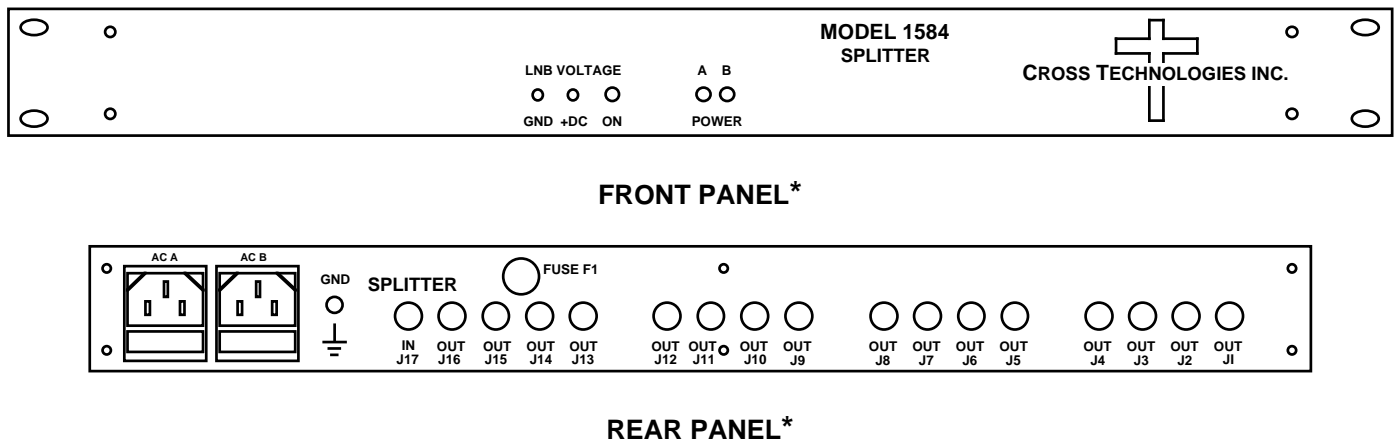

**FIGURE 1.1 MODEL 1584-116 FRONT AND REAR PANELS**

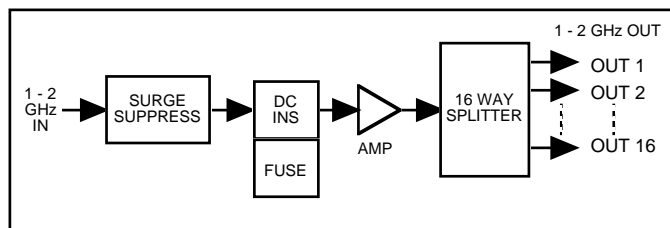

**FIGURE 1.2 MODEL 1584-116 BLOCK DIAGRAM**

**\*NOTE:** Model 1584-116S has a single non-redundant, switching power supply.

## 1.2 Technical Characteristics

**TABLE 1.0 1584-116 SPECIFICATIONS**

<u>Characteristics</u>	<u>Specifications**</u>
<b>Input Characteristics</b>	
Input Impedance	75Ω (50Ω, option -D)
Return Loss	12 dB min.; 14 dB typical.
Input Level	-20 dBm total maximum
<b>Output Characteristics</b>	
Impedance	75Ω (50Ω, option -D)
Return Loss	12 dB min.; 14 dB typical.
<b>In-Band Characteristics</b>	
Gain	+0 dB ± 1.0 dB
Frequency Response	± 1.0 dB; 0.95 to 2.05 GHz ± 0.5 dB, any 20 MHz incr.
Port to Port Isolation	> 18 dB, min., 20 dB typical.
<b>Indicators</b>	
AC Power (A & B)	Green LED indicates DC voltage prior to diode OR and to amplifiers
LNB DC Voltage	Green LED indicates LNB power insertion on splitter input (J17)
<b>Other</b>	
LNB DC voltage	22 ± 2 VDC
Output LNB current	300 ma, max.
Surge Suppressor	SiDACTOR
RF connectors	Type-F, female (BNC, female - options -B and -D)
Fuses - AC	5mm, 2 amp, slow blo
Fuse - LNB Voltage	1/4", 0.5 amp, fast blo
AC Power	Redundant power supplies, 100-240 ± 10% VAC, 50 - 60 Hz, 30 watts max. <b>*NOTE: Model 1584-116S has a single non-redundant, switching power supply and does NOT provide the LNB Power Insertion feature.</b>
Mechanical	19 inch standard chassis 1.75" high X 12" deep
<b>Options</b>	
B	BNC, 75Ω RF connectors
D	BNC, 50Ω RF connectors
W9*	10MHz pass thru (J17 to J16)

\*\*+10°C to +40°C; Specifications subject to change without notice.

## 2.0 Installation

**2.1 Mechanical** - The 1584-116/116S consists of one RF printed circuit board (PCB) housed in a 1 RU (1.75 inch high) by 12 inch deep chassis. Redundant, switching, +24 VDC power supplies with the DC output diode OR'd provide redundant power for the internal and external amplifiers and LEDs. (Model 1584-116S has a single non-redundant, switching power supply). Connectors are type F, female for the RF connections (BNC, female option -B or -D). The 1584-116/116S can be secured to a rack using the 4 holes on the front panel. Figure 2.0 shows how the 1584-116/116S is assembled. J25 connects DC Power to the fuse as shown and J30 and J29 connect the DC voltage from the power supplies to the PCB as shown.

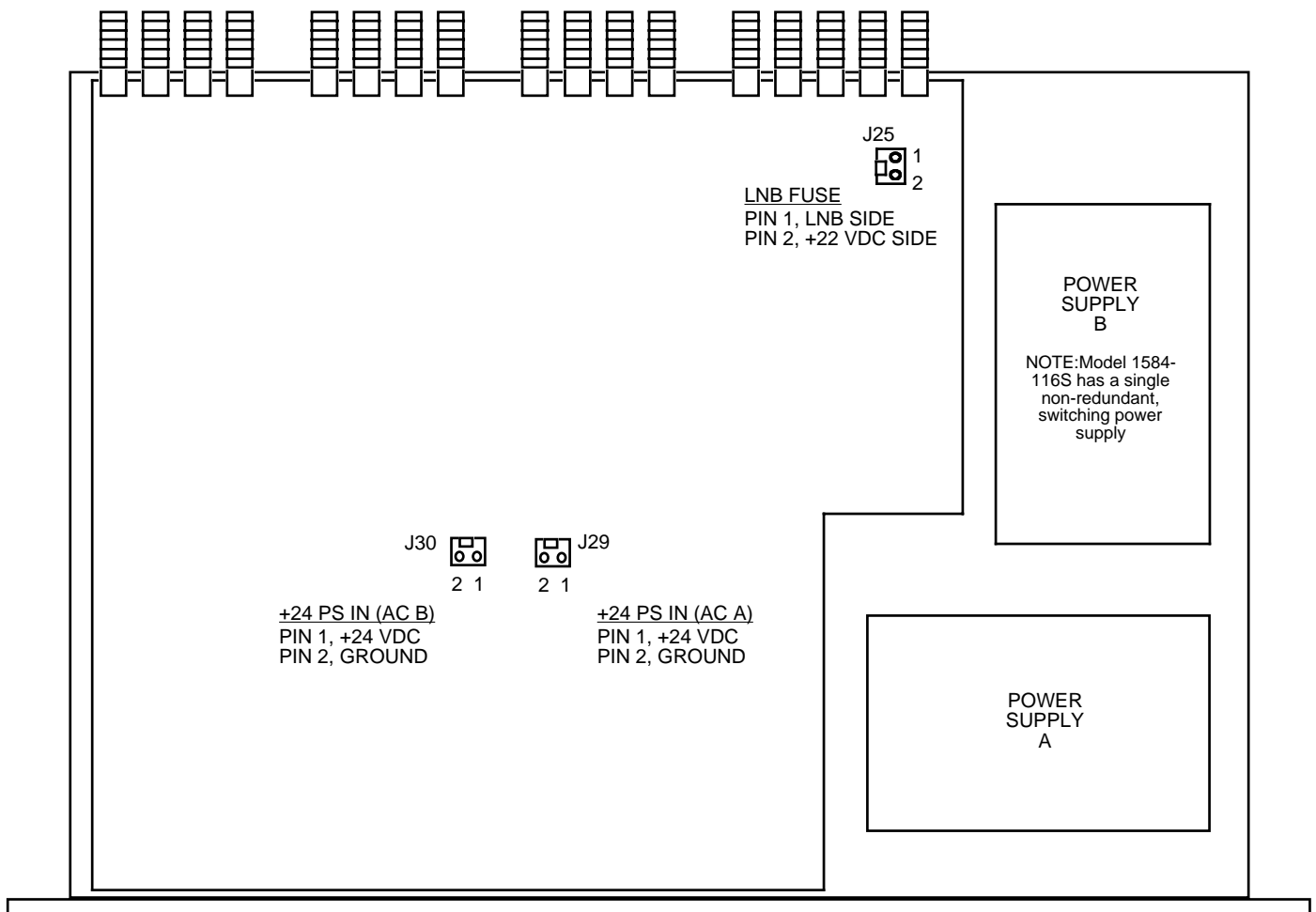
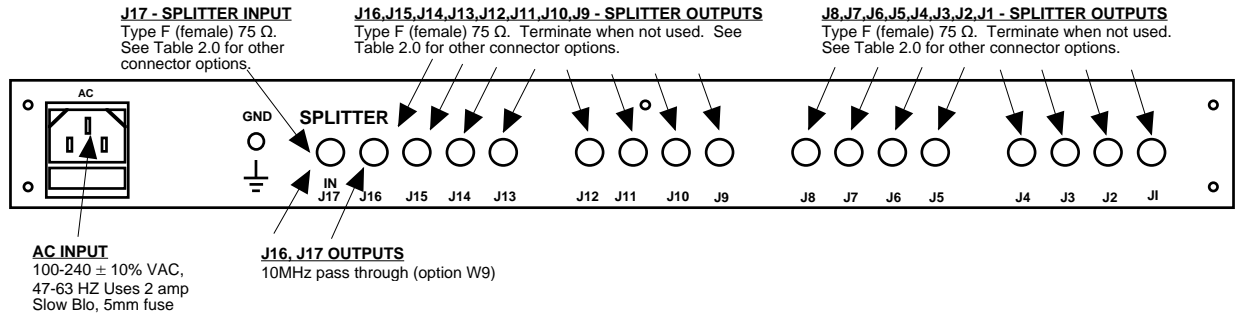

**FIGURE 2.0 1584-116 MECHANICAL ASSEMBLY**

## 2.2 Rear Panel Input/Output Connectors

The input and output connectors on the rear panel are shown in Figure 2.1.

**CAUTION!** IF A FUSE IS INSTALLED IN THE FUSE F1 HOLDER, +22 VDC WILL APPEAR ON THE SPLITTER INPUT CONNECTOR (J17) CENTER PIN.

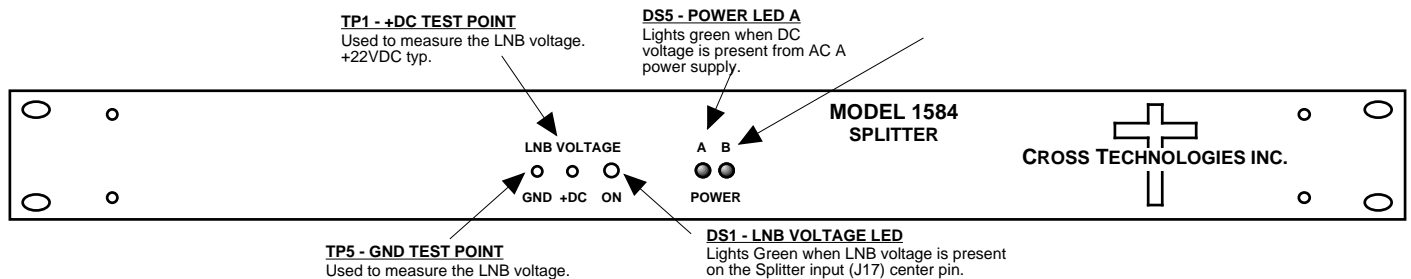

**FIGURE 2.1 1584-116 REAR PANEL**

TABLE 2.0 RF Connector Options	
Option	RF Connectors
STD	Type F, 75Ω
-B	BNC, 75Ω
-D	BNC, 50Ω
-W9	10MHz pass through -116S

## 2.3 Front Panel Monitors and Indicators

Figure 2.2 shows the front panel monitors and indicators.



**FIGURE 2.2 1584-116 FRONT PANEL**

**\*NOTE:** Model 1584-116S has a single non-redundant, switching power supply.

## 2.4 Operation

1. Connect RF cables to the 1584-116 (See Section 2.2).
2. IF DC VOLTAGE IS REQUIRED ON THE SPLITTER RF INPUT (J17) CENTER CONDUCTOR, install 1/4", 0.5 amp fast blo fuses in the FUSE F1 holder
3. Connect 100-240  $\pm$  10% VAC, 47 - 63 Hz to AC A and AC B on the back panel and observe A and B LEDs are lit on the front panel.\*
4. Monitor DC voltage to the external LNB amplifier (Front panel Green ON LED should be lit if LNB fuse is installed in the rear panel fuse holder) to insure proper voltage.

**\*NOTE: Model 1584-116S has a single non-redundant, switching power supply.**

---

**CAUTION!** IF A FUSE IS INSTALLED IN THE FUSE F1 HOLDER, +22 VDC WILL APPEAR ON THE SPLITTER INPUT CONNECTOR (J17) CENTER PIN.

---

**NOTE:** FOR OPTIMUM PERFORMANCE, THE SPLITTER PORTS SHOULD BE TERMINATED WITH 75 OHM TYPE F TERMINATION WHEN NOT USED.

**AC Fuse** - The fuse is a 5mm, 2 amp slow blo and is inserted in the far slot in the drawer below the AC input as shown in Figure 2.6. There is a spare fuse in the near slot. If a fuse continues to open, the power supply is most likely defective. Note that each power supply module within the chassis also has a fuse but failure of this fuse indicates the power supply may be defective.

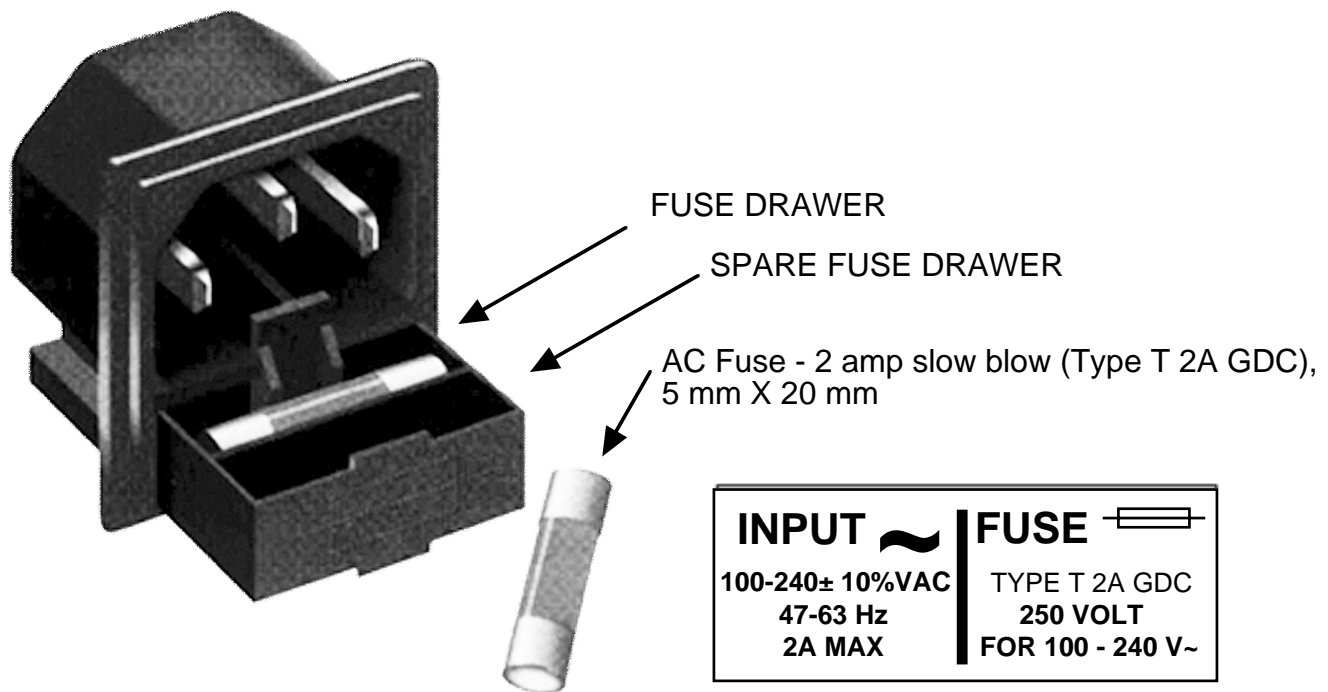

**FIGURE 2.6 FUSE LOCATION AND SPARE FUSE**

## 2.5 Environmental Use Information

- A. **Rack-Mounting** - To mount this equipment in a rack, please refer to the installation instructions located in the user manual furnished by the manufacturer of your equipment rack.
- B. **Mechanical loading** - Mounting of equipment in a rack should be such that a hazardous condition does not exist due to uneven weight distribution.
- C. **Elevated operating ambient temperature** - If installed in a closed or multi-unit rack assembly, the operating ambient temperature of the rack may be greater than room ambient temperature. Therefore, consideration should be given to Tmra.
- D. **Reduced air flow** - Installation of the equipment in a rack should be such that the amount of air flow required for safe operation of the equipment is not compromised. Additional space between unit may be required.
- E. **Circuit Overloading** - Consideration should be given to the connection of the equipment to the supply circuit and the effect that overloading of circuits could have on over current protection and supply wiring. Appropriate consideration of equipment name plate rating should be used, when addressing this concern.
- F. **Reliable Earthing** - Reliable earthing of rack-mounted equipment should be maintained. Particular attention should be given to supply connections other than direct connection to the Branch (use of power strips).
- G. **Top Cover** - There are no serviceable parts inside the product so, the Top Cover should not be removed. If the Top Cover is removed the ground strap and associated screw **MUST BE REINSTALLED** prior to Top Cover screw replacement. **FAILURE TO DO** this may cause **INGRESS** and/or **EGRESS** emission problems.





6170 Shiloh Road  
Alpharetta, Georgia 30005

(770) 886-8005  
FAX (770) 886-7964  
Toll Free 888-900-5588

WEB [www.crosstechnologies.com](http://www.crosstechnologies.com)  
E-MAIL [info@crosstechnologies.com](mailto:info@crosstechnologies.com)

2010, Printed in USA