

Instruction Manual

Model 1582-25L RF Switch

August 2012, Rev. E

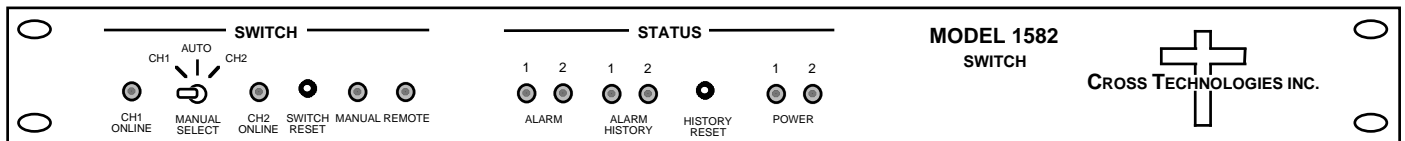

Data, drawings, and other material contained herein are proprietary to Cross Technologies, Inc., but may be reproduced or duplicated without the prior permission of Cross Technologies, Inc. for purposes of operating the equipment.

When ordering parts from Cross Technologies, Inc., be sure to include the equipment model number, equipment serial number, and a description of the part.



6170 Shiloh Road
Alpharetta, Georgia 30005

(770) 886-8005
FAX (770) 886-7964
Toll Free 888-900-5588

WEB www.crosstechnologies.com
E-MAIL info@crosstechnologies.com

INSTRUCTION MANUAL

MODEL 1582-25L RF Switch

<u>TABLE OF CONTENTS</u>	<u>PAGE</u>
Warranty	2
1.0 General	3
1.1 Equipment Description	3
1.2 Technical Characteristics	4
2.0 Installation	5
2.1 Mechanical	5
2.2 Input and Output Signals	6
2.3 Controls and Indicators	7
2.4 Operation	8
2.5 Switch Mode Setup	9
3.0 Environmental Use Information	11

WARRANTY - The following warranty applies to all Cross Technologies, Inc. products.

All Cross Technologies, Inc. products are warranted against defective materials and workmanship for a period of one year after shipment to customer. Cross Technologies, Inc.'s obligation under this warranty is limited to repairing or, at Cross Technologies, Inc.'s option, replacing parts, subassemblies, or entire assemblies. Cross Technologies, Inc. shall not be liable for any special, indirect, or consequential damages. This warranty does not cover parts or equipment which have been subject to misuse, negligence, or accident by the customer during use. All shipping costs for warranty repairs will be prepaid by the customer. There are not other warranties, express or implied, except as stated herein.



6170 Shiloh Road
Alpharetta, Georgia 30005

(770) 886-8005
FAX (770) 886-7964
Toll Free 888-900-5588

WEB www.crosstechnologies.com
E-MAIL info@crosstechnologies.com

MODEL 1582-25L RF Switch

1.0 General

1.1 Equipment Description

The 1582-25L RF Protection Switch provides Auto, Manual or Remote latched relay switching between CH1 and CH2 RF signals from DC to 2.5 GHz including up to 0.5A DC power for attached LNBS. Alarm conditions on CH1 and CH2 are either a contact closure to ground or an open (selectable). The logic controls two separate RF switches, X and Y. Switching logic can be selected as follows:

1. CH1 Prime Mode - Switches from CH1 to the CH2 only if CH1 alarms and CH2 is good. Switches back when CH1 no longer in alarm or both CH1 and CH2 are bad.
2. Latch to CH2 Mode - Switches to CH2 if CH1 alarms and CH2 is good. Latches to CH2. Push Manual Reset or ground Remote Reset pin to return to CH1 if it has no alarm.
3. Minimum AUTO switching, Initial Channel Select (ICS) Mode - Switch stays on channel last selected by Manual or Remote selection after return to AUTO. AUTO switching occurs only if current channel alarms and other channel is clear.

When power is lost and when power is applied (as alarms at power up dictate), the selected channel remains on. The Manual Select switch and (when in AUTO) contact closures to Remote Select pins select CH1 or CH2 independent of alarms. LEDs indicate alarm and switch conditions for CH1 and CH2 and REMOTE or MANUAL operation. Redundant power supplies are provided.

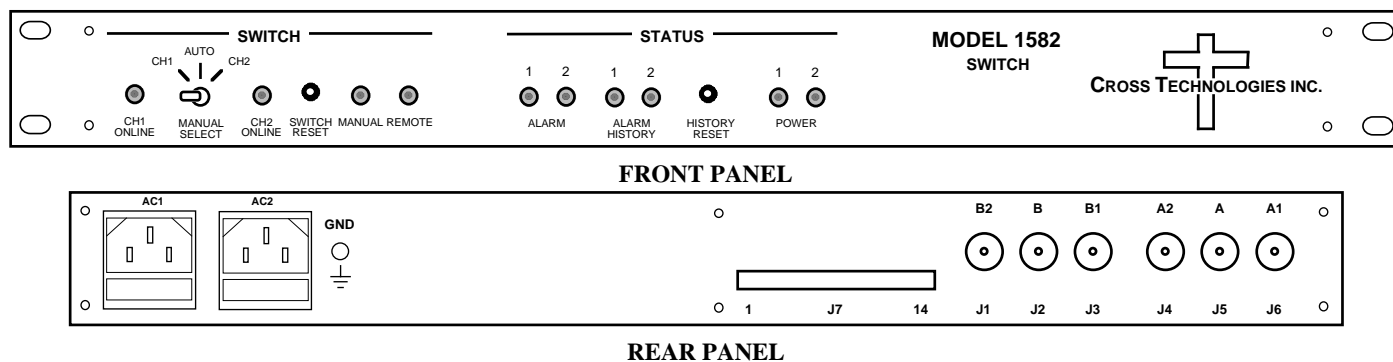

FIGURE 1.1 Model 1582-25L Front and Rear Panels

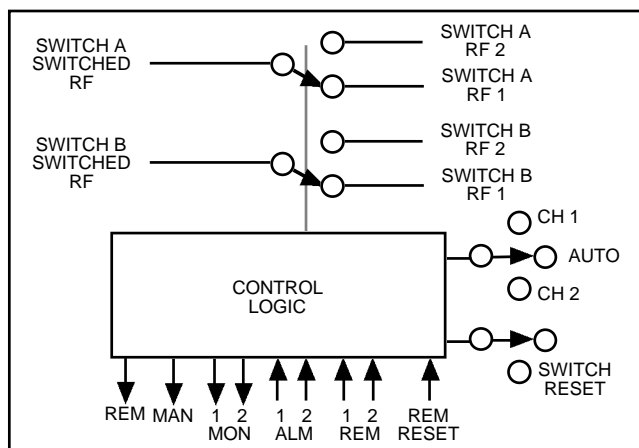

FIGURE 1.2 Model 1582-25L RF Switch Block Diagrams

1.2 Technical Characteristics

TABLE 1.1 1582-25L RF Switch Specifications*

Switch Characteristics

Impedance	75 Ω
Type	Latching Relay
Configuration	DPDT
Insertion Loss	1.5 dB max., \leq 1 dB typ. (DC to 1.5 GHz) 2.5dB max., \leq 2.0 dB typ., (1.5 to 2.5 GHz)
Frequency Response	DPDT
Return Loss	\geq 12 dB, \geq 14 dB typ. (DC to 1.5 GHz) \geq 10 dB, \geq 12 dB typ. (1.5 to 2.5 GHz)
Isolation	55 dB min., \geq 60 dB typ. (DC to 1.5 GHz) 45 dB min., \geq 50 dB typ. (1.5 to 2.5 GHz)
Switch Time	\leq 10 ms
DC Switching	30VDC max., 0.5 Amps max.

Controls

MANUAL SELECT	Manually select CH1 or CH2
SWITCH RESET	Resets to CH1 in latch mode, and resets REMOTE
HISTORY RESET	Resets alarm history (prior occurrence of alarms now cleared) - LEDs only
MANUAL SELECT	Manually select CH1 or CH2

Indicator LEDs

CH1 ON-LINE [†]	Turns green when Channel 1 is selected
CH2 ON-LINE [†]	Turns green when Channel 2 is selected
MANUAL [†]	Turns red when the Manual Select switch manually selects channel 1 or 2.
REMOTE [†]	Turns amber when REMOTE control is active
ALARM CH1	Turns red when Channel 1 alarm input is a closure or open (selectable)
ALARM CH2	Turns red when Channel 2 alarm input is a closure or open (selectable)
ALARM HISTORY 1	Turns red on Channel 1 alarm and stays red until HISTORY RESET is pushed
ALARM HISTORY 2	Turns red on Channel 2 alarm and stays red until HISTORY RESET is pushed
POWER CH1	Turns green when power is applied to AC1 input on the rear panel
POWER CH2	Turns green when power is applied to AC2 input on the rear panel
MANUAL SELECT	Manually select CH1 or CH2

[†] Also closures at connector J7 on rear panel

Other

Alarm/Control Conn.	Terminal Strip
RF Connectors	BNC (female), 75 Ω (see Table 2.2 for other options)
Mechanical	19-inch standard 1RU chassis, 1.75"H x 12"D
Power	Redundant power supplies; 100-240 \pm 10% VAC, 47-63 Hz, 30 W

Available Options

W31	Extended Temperature Range Testing; 0°C to 50°C
W72	Alternate Switching Voltage: GP10, 2.7V, DC Trigger

*+10°C to +40°C; 2000m max. elevation; 80% max. humidity; Specifications subject to change without notice.

2.0 Installation

2.1 Mechanical

The 1582-25L consists of one RF/Controller PCB and one smaller PCB containing the RF inputs and outputs. It is housed in a 1 RU (1 3/4 inch high) by 12 inch deep chassis. Redundant switching power supplies provide power for the assembly. The 1582-25L can be secured to a rack using the 4 holes on the front panel.

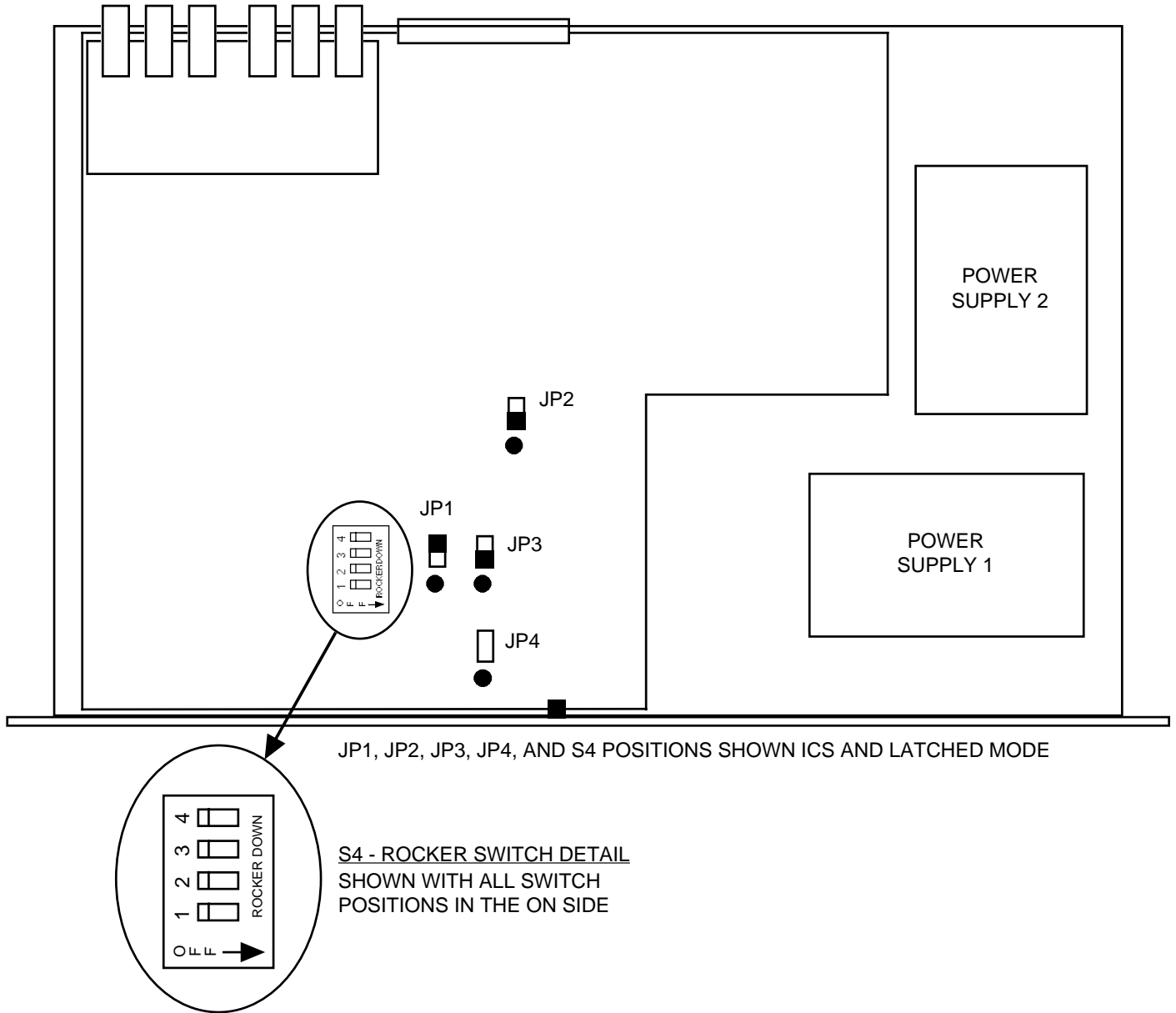

FIGURE 2.1 1582-25L RF Switch Assembly

2.2 Input and Output Signals - Figure 2.2 shows the input and output connectors on the rear panel.

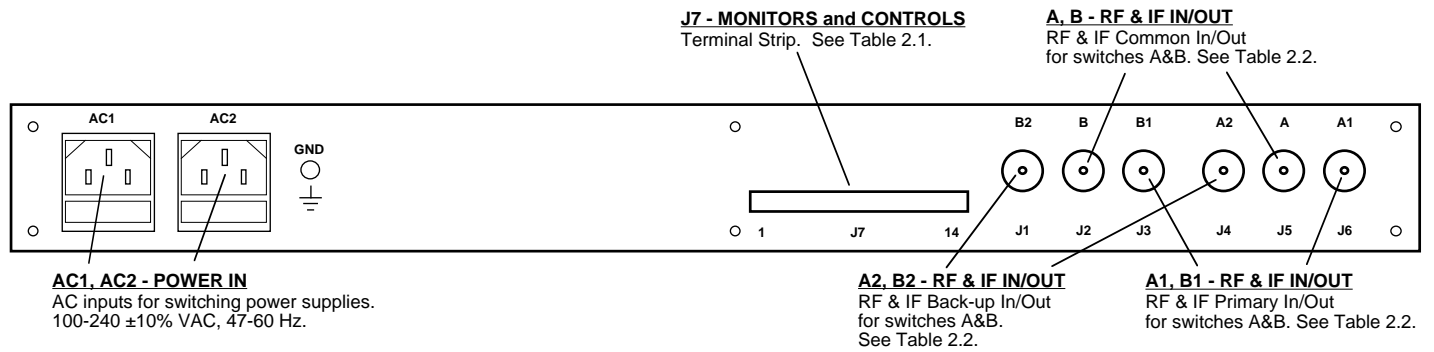

FIGURE 2.2 1582-25L RF Switch Rear Panel Inputs/Outputs

Table 2.1 J7 Pinouts (Monitors and Controls)		
Pin	Function	Description
1	REMOTE 1 IN	When in AUTO, momentary ground on this pin selects CH1
2	REMOTE 2 IN	When in AUTO, momentary ground on this pin selects CH2
3	GROUND	Ground
4	REMOTE RESET IN	When in LATCH mode, ground resets switch to CH1
5	NC	Not Connected
6	SWITCH COMMON	Common pin for SWITCH 1, 2
7	GROUND	Ground
8	MANUAL	*Open collector output (< 5Ω) to GND when in MANUAL mode
9	REMOTE	*Open collector (< 5Ω) to GND when in REMOTE mode
10	GROUND	Ground
11	SWITCH 1	**Relay closure to J7 pin 6 (<5Ω) when CH1 RF is selected
12	SWITCH 2	**Relay closure to J7 pin 6 (<5Ω) when CH2 RF is selected
13	ALARM 1 IN	Ground or Open (selectable by JP2) is CH1 alarm
14	ALARM 2 IN	Ground or Open (selectable by JP2) is CH2 alarm

* Max voltage to be connected is +20 VDC @ 30mA

** Max voltage to be connected is +30 VDC @ 100mA

TABLE 2.2 RF Connection Options

Option	RF (Switch A, In/Out)		IF (Switch B, In/Out)	
	RF Common (A)	RF (A1, A2)	IF Common (B)	IF (B1, B2)
STD	BNC, 75Ω	BNC, 75Ω	BNC, 75Ω	BNC, 75Ω
D	BNC, 50Ω	BNC, 50Ω	BNC, 50Ω	BNC, 50Ω
J	F-type, 50Ω	F-type, 50Ω	BNC, 50Ω	BNC, 50Ω
M	N-type, 50Ω	BNC, 50Ω	BNC, 50Ω	BNC, 50Ω
N	N-type, 50Ω	BNC, 50Ω	BNC, 75Ω	BNC, 75Ω

NOTE When the 1582 RF Switch is installed into a system, J7 Pins 13 and 14 (Alarms In) and appropriate grounds must be interconnected between the primary(s), backup(s) and the 1582 RF Switch for proper switch function.

2.3 Controls and Indicators - The following are the front panel controls and indicators.

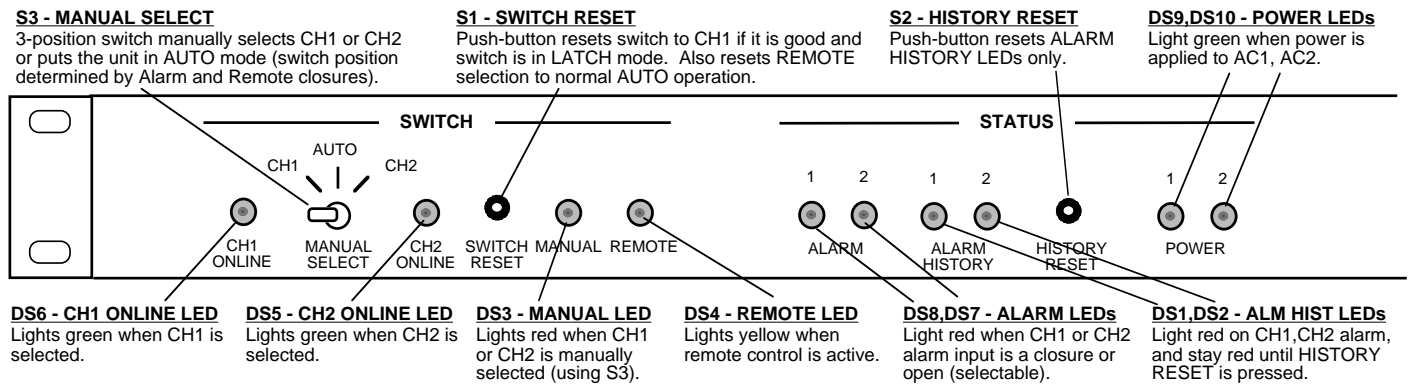

FIGURE 2.3 1582-25L Front Panel Controls and Indicators

2.3.1 PC Board Settings

NOTE: Dot position means jumper goes from pins 1-2; non-dot means jumper goes from pins 2-3

JP1 - 3-pin jumper - 3-pin jumper that works with JP3

In the dotted position when CH1 alarms the 1582-25L will switch to CH2 until CH2 alarms. At this point, if CH1 is still in alarm, the switch will stay on CH2. When the CH1 alarm clears if CH2 is still in alarm, the switch will switch to CH1.

- JP1 normal position - **dot** (operates in conjunction with JP3 as noted below)

JP2 - Input Alarm Condition 3-pin jumper

In the dotted position open is normal, ground is alarm

In the non-dot position ground is normal, open is an alarm.

- JP2 normal position - **dot**

JP3 - LATCH to CH2 mode ON / OFF - 3-pin jumper effective when JP1 is in the non-dot position.

With JP3 in the dot and JP1 in the non-dot, when channel 1 alarms, the 1582-25L switch switches to channel 2 and stays there until the reset button is pushed on the front panel or by an external closure to ground on the remote RESET pin on J7, and then it switches to channel 1. (If channel 1 alarms are cleared). If in the ICS mode and originally set to CH2 the 1582-25L will not switch if CH2 alarms. Only the RESET functions (front panel pushbutton or J7 closure to ground) will return the switch to CH1.

With JP3 in the non-dot and JP1 in the non-dot, when channel 1 alarms the 1582-25L switches to channel 2 until the alarm on channel 1 clears and then the 1582-25L switches back to channel 1 automatically.

- JP3 normal position - **dot**

JP4 - CH2 Alarm Enable / Ignore - 3-pin jumper

Dotted position - Failure in CH1 will cause a switch to CH2 even if CH2 is in alarm. LEDs will correctly show CH2 alarm status.

Non-dotted position - Failure in CH1 will cause a switch to CH2 only if CH2 is not in alarm.

- JP4 normal position - **non-dot**

S4 - Initial Channel Select (ICS) Mode - 4-position DIP switch Selects the Initial Channel Select mode when JP1, JP2, JP3 in Dot and JP4 in Non-dot.

S4 positions 1,2,3,4 to ON - ICS enabled. In the ICS mode, the initial channel can be either CH1 or CH2 by switching the front panel MANUAL SELECT switch to either CH1 or CH2 and then back to the AUTO position or by grounding either REMOTE 1 or REMOTE 2 pins on J7 and then grounding the REMOTE RESET pin on J7 causing the 1582-25L to go back to AUTO in the channel last selected remotely if both channel alarms are clear or both channels are in alarm. The initial channel can also be selected if both channel alarms are clear or both channels are in alarm.

S4 positions 1,2,3,4 to OFF - ICS disabled (Minimum Auto switching, Return to Last State Mode) The 1582-25L goes to the last state (CH1 or CH2) it was in when in AUTO after manually or remotely switching and returning to AUTO. Auto switching occurs only if current channel alarms and the other channel is clear.

S4 normal position - 1,2,3,4 to ON

2.4 Operation

1. Set the on board controls as desired (see Sections 2.3.1 and 2.5, and Figure 2.1).
2. Install the 1582-25L in the equipment rack.
3. Connect RF to the BNC connectors (J1-J6 and J8-J13).
4. Connect to signals on the MONITORS AND CONTROLS connector, J7, as desired (see Figure 2.2, Table 2.1).
5. Connect power via two power cords to AC1 and AC2.
6. Manually switch between channels 1 and 2 and be sure switching occurs.
7. Switch to AUTO. Alarm channel 1 and note that automatic switching occurs. Remove alarm to CH1 and note that the output switches as desired. Push RESET if in LATCH mode. Repeat for CH2.
8. Check that CH1 and CH2 are selected when in AUTO and momentary ground is applied to J7 pins 1 and 2. Momentarily ground Remote Reset pin 4 on J7 if in LATCH mode to return to AUTO operation.

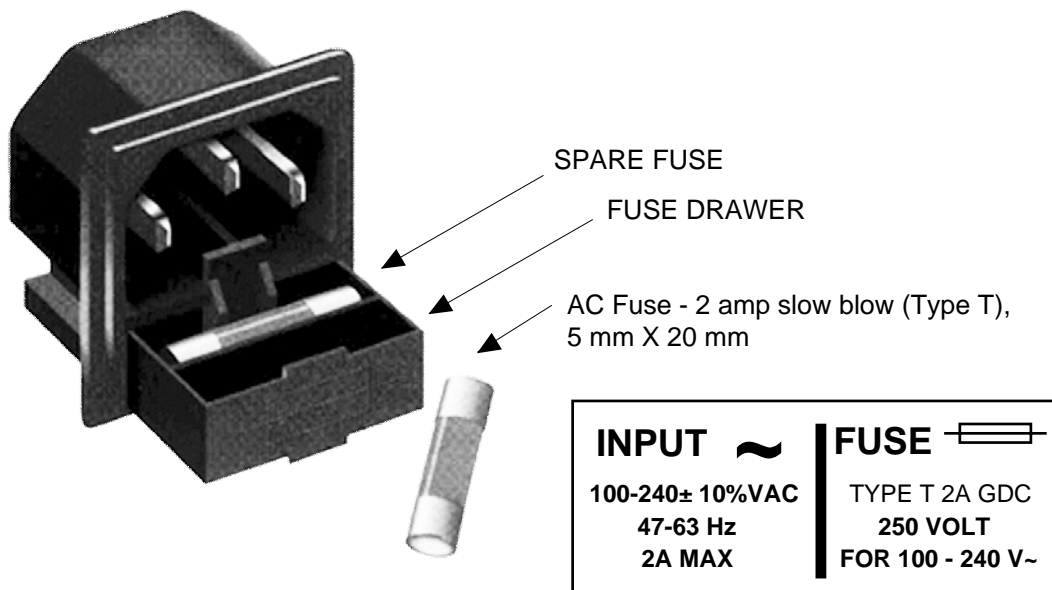

FIGURE 2.4 Fuse and Spare Fuse Locations

2.5 Switch Mode Setup

The following gives the switch mode settings of the on board controls that can be changed in the field with JP1, JP2, JP3, JP4; S4. (Figure 2.3). All shown with external **alarm = ground**.

1) CH1 Prime Mode - Switches from CH1 to the CH2 only if CH1 alarms and CH2 is good. Switches back to CH1 when it is no longer in alarm or when both CH1 and CH2 are in alarm

Non-dot JP1, JP3, JP4;

Dot - JP2;

S4 - ALL TO OFF.

2) Latch to CH2 Mode - Switches from CH1 to CH2 if CH1 alarms and CH2 is good. Latches to CH2. Push Reset or ground Remote Reset pin to return to CH1 if it has no alarm or both CH1 and CH2 are in alarm.

Non-dot - JP1, JP4;

Dot - JP2, JP3;

S4 - ALL TO OFF.

3) Minimum Auto switching, Initial Channel Select (ICS) Mode - Switch stays on channel last selected by Manual or Remote selection after return to AUTO if both channel alarms are clear or both channels are in alarm. Auto switching occurs only if current channel alarms and the other channel is clear.

Non-dot - JP4;

Dot - JP1, JP2, JP3;

S4 - ALL TO ON.

Factory set mode is generally **1) CH1 Prime Mode**.

3.0 Environmental Use Information

- A. **Rack-Mounting** - To mount this equipment in a rack, please refer to the installation instructions located in the user manual furnished by the manufacturer of your equipment rack.
- B. **Mechanical loading** - Mounting of equipment in a rack should be such that a hazardous condition does not exist due to uneven weight distribution.
- C. **Elevated operating ambient temperature** - If installed in a closed or multi-unit rack assembly, the operating ambient temperature of the rack may be greater than room ambient temperature. Therefore, consideration should be given to Tmra.
- D. **Reduced air flow** - Installation of the equipment in a rack should be such that the amount of air flow required for safe operation of the equipment is not compromised. Additional space between units may be required.
- E. **Circuit Overloading** - Consideration should be given to the connection of the equipment to the supply circuit and the effect that overloading of circuits could have on over current protection and supply wiring. Appropriate consideration of equipment name plate rating should be used, when addressing this concern.
- F. **Reliable Earthing** - Reliable earthing of rack-mounted equipment should be maintained. Particular attention should be given to supply connections other than direct connection to the Branch (use of power strips).
- G. **Top Cover** - There are no serviceable parts inside the product so, the Top Cover should not be removed. If the Top Cover is removed the ground strap and associated screw **MUST BE REINSTALLED** prior to Top Cover screw replacement. **FAILURE TO DO** this may cause **INGRESS** and/or **EGRESS** emission problems.



6170 Shiloh Road
Alpharetta, Georgia 30005

(770) 886-8005
FAX (770) 886-7964
Toll Free 888-900-5588

WEB www.crosstechnologies.com
E-MAIL info@crosstechnologies.com

Printed in USA