

**2083-1522 Block Translator, 1540-1560 to 2240-2260 MHz**

**2083-1522 Block Translator** - The 2083-1522 Block Translator converts a 1540-1560 MHz block to 2240-2260 MHz block with no spectrum inversion, low group delay and flat frequency response. The 1540-1560 MHz input is filtered and translated to the 2240-2260 MHz block output using a 700 MHz LO. The gain can be set for 0 to +20 dB in 1 dB increments. The output translation can be adjusted by  $\pm 10$  MHz in 1 MHz (**10 Hz, Option -X10**) increments. Multifunction switches select the Gain, the LO translation frequency and internal or External 10 MHz reference which appear on the LCD display and can be adjusted remotely. Front panel LEDs provide indication of DC power (green), PLL alarm (red), and remote operation (yellow). Connectors are **BNC female** for RF input and output. The unit is powered by a 100-240  $\pm 10\%$  VAC, 47-63 HZ input power supply and housed in a 1 3/4" X 19" X 16" rack mount chassis.

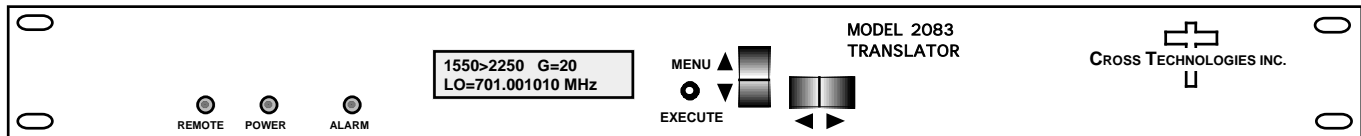

**2083-1522 Block Translator**

**EQUIPMENT SPECIFICATIONS\***

**Input Characteristics**

Input Impedance/RL **50 $\Omega$  /12 dB**  
 Frequency **1540 - 1560 MHz**  
 Input **Composite** Level **-70 to -50 dBm**  
 Input, max. no damage **+15 dBm**

**Output Characteristics**

Impedance/RL **50 $\Omega$  /12 dB**  
 Frequency **2240 - 2260 MHz**  
 Output **Composite** Level **-50 to -30 dBm**  
 Output 1 dB compression **-20 dBm, at max gain**

**Channel Characteristics**

Gain **0 to +20 dBm,  $\pm 1$  dB, selectable in 1 dB steps**  
 Frequency Response  **$\pm 1.0$  dB, 20 MHz bandwidth;  $\pm 0.5$  dB, any 5 MHz increment**  
 Spurious, Inband **< -50 dBC in band, signal dependent and signal independent; See NOTE 1**  
 Spurious, out of band **< -30 dBC, 1.6- 2.2 GHz and 2.3-3.0 GHz and 1.54-1.56 GHz feed through rejection; See NOTE 1**  
 Group Delay, max. **0.03 ns/MHz<sup>2</sup>, parabolic, 0.1ns/MHz, linear, 1 ns ripple, 20 MHz BW**  
 Frequency Sense **Non-inverting**

**Synthesizer Characteristics**

LO Frequency; Accuracy **700 MHz; 1ppm; Option -H,  $\pm 0.01$  ppm**  
 Reference **10 MHz Internal; Option -E, Internal/ External selection**  
 Frequency Step **1 MHz;  $\pm 10$  MHz Translation adjustment: Option -X10, 10 Hz adjustment**

Phase Noise @ F (Hz) >	100	1K	10K	100K	1M
dBC/Hz	-70	-70	-80	-90	-100

**Controls, Indicators**

Frequency Translation **Direct readout LCD; manual or remote selection**  
 Gain (MGC) **Direct readout LCD; manual or remote selection**  
 Ext. ref. (Option -E) **Direct readout LCD; manual or remote selection**  
 Power; Alarm; Remote **Green LED; Red LED; Yellow LED**  
 Remote **RS232C, 9600 baud , W8, W18 Ethernet Options**

**Other**

RF In/RF Out Connector **BNC (female)**  
 Alarm/Remote Connector **DB9 (female) - NO or NC contact closure on Alarm**  
 Size **19 inch standard chassis 1.75" High X 16.0" Deep**  
 Power **100-240 ( $\pm 10\%$ ) VAC, 47-63 Hz, 30 watts max.**

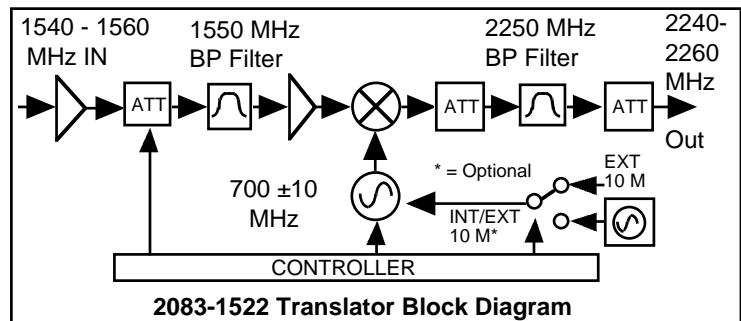

**2083-1522 Translator Block Diagram**

**NOTE 1:** dBC is relative to the COMPOSITE Output Level

**Available Options**

- X10-** 10 Hz Tuning
- E -** External 10 MHz Reference input & output
- H-**  $\pm 0.01$  ppm Internal Reference
- M&C Interface** RS232 Std.
  - Q -** RS485 Remote Interface
  - W8 -** Ethernet M&C Web Browser Interface
  - W18 -** Ethernet M&C Web Browser Interface and SNMP

**Connector/Impedance**

- B -** 75 $\Omega$  BNC (RF In), 75 $\Omega$  BNC (RF Out)
- NN -** N for input and output

\*+10 to +40 degrees C; Specifications subject to change without notice