

## 2016-02-720 L-Band Downconverter, 720 ±100 MHz IF

The 2016-02-720 Downconverter converts 950 to 2150 MHz to 720 MHz in **125 kHz** steps with low group delay and flat frequency response. Synthesized local oscillators (LO) provide frequency selection. Multi-function switches select the input frequency, gain, and other parameters. Front panel LEDs provide indication of DC power, PLL alarm or Remote operation. Gain is adjustable manually (MGC) over a 0 to **+30 dB** range. The frequency and gain are remotely selectable. Parameter selection and frequency and gain settings appear on the LCD display. Connectors are Type F female for the RF, and BNC female for the IF and **external 10 MHz reference input and output. External 10 MHz is standard. A 10 MHz output connector contains either the internal or external 10 MHz reference signal whichever is selected by the user.** The 2016-02-720 is powered by a 100-240 ±10% VAC, 47-63 Hz power supply, and is contained in a 1 3/4" X 19" X 16" rack mount chassis.

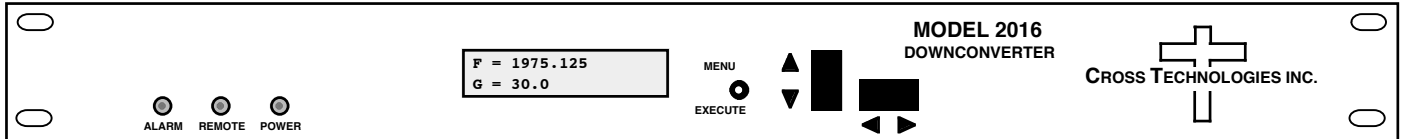

**Front Panel**

### EQUIPMENT SPECIFICATIONS\*

#### Input Characteristics

Impedance/Return Loss	75Ω/10 dB
Frequency	950 to 2150 MHz
Noise Figure, Max.	20 dB max. gain
Input Level range	-50 to -20 dBm

#### Output Characteristics

Impedance/Return Loss	50 Ω /14 dB
Frequency	720 ± 100 MHz
Output Level Range	-20 to -10 dBm
Output 1 dB compression	0 dBm, max. gain

#### Channel Characteristics

<b>Gain range (adjustable)</b>	<b>0.0 to +30.0 dB, 1 ±1 dB steps</b>
<b>Image Rejection</b>	<b>&gt; 45 dB, min., 50 dB typical</b>
<b>Frequency Response</b>	<b>±2.0 dB, 950 to 2150 MHz; ±1.0 dB, 200 MHz BW</b>
Spurious Response	< -45 dBc, in band
<b>Group Delay, max</b>	<b>10 ns total, Max. (parabolic + linear + ripple), 200 MHz BW</b>
<b>Frequency Sense</b>	<b>Non-inverting</b>

#### Synthesizer Characteristics

Frequency Accuracy	± 1.0 ppm max. over temp (± 0.01 ppm option -H)
Frequency Step	<b>125 kHz</b>

Phase Noise @ Freq	100Hz	1kHz	10kHz	100kHz	1MHz
dBC/Hz	-70	-70	-80	-90	-100

10 MHz Level (In or Out) **3 dBm, ± 3 dB, 75 ohms**

#### Controls, Indicators

Frequency Selection	Direct readout LCD; manual or remote selection
Gain Selection	Direct readout LCD; manual or remote selection
Power; Alarm; Remote	Green LED; Red LED; Yellow LED
Remote	RS232C, 9600 baud ( <b>RS485, Ethernet Optional</b> )

#### Other

RF Connector	Type F (female)
IF, 10 MHz Connectors	BNC (female)
Alarm/Remote Connector	DB9 (female) - NO or NC contact closure on Alarm
Size	19 inch, 1RU standard chassis 1.75" high X 16.0" deep
Power	100-240 ± 10% VAC, 47-63 Hz, <b>30 watts max.</b>

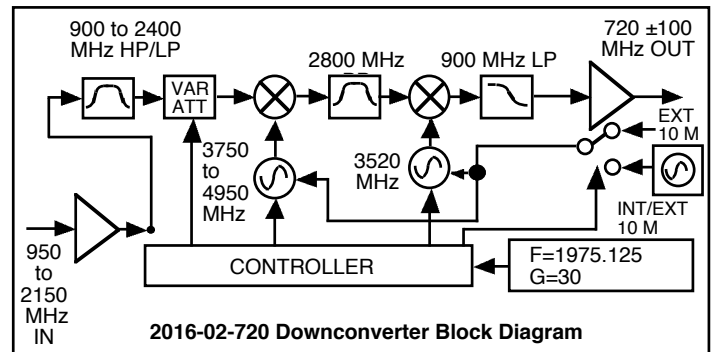

**2016-02-720 Downconverter Block Diagram**

#### Available Options

- H - High Stability (±0.01ppm) Internal Ref
- Q - RS485 Remote Interface
- W8 - Ethernet; w/Web Browser (WB)**
- W18 - Ethernet; w/WB & SNMP**
- W28 - Ethernet; w/TCP/IP, Telnet®**
- Connectors/Impedance**
- STD - 75Ω Type F (RF), 50Ω BNC (IF)
- B - 75Ω BNC (RF), 75Ω BNC (IF)
- C - 50Ω BNC (RF), 75Ω BNC (IF)
- D - 50Ω BNC (RF), 50Ω BNC (IF)
- F - 75Ω Type F (RF), 75Ω BNC (IF)
- K - 75Ω BNC (RF), 50Ω BNC (IF)
- M - 50Ω Type N (RF), 50Ω BNC (IF)
- N - 50Ω Type N (RF), 75Ω BNC (IF)
- S - 50Ω SMA (RF), 50Ω BNC (IF)

\*10°C to 40°C; Specifications subject to change without notice