

## 1582-25L RF Protection Switch

The 1582-25L RF Protection Switch provides Auto, Manual or Remote latched relay switching between CH1 and CH2 RF signals from DC to 2.5 GHz including up to 0.5A DC power for attached LNBS. Alarm conditions on CH1 and CH2 are either a contact closure to ground or an open (selectable). The logic controls two separate RF switches, A and B. Switching logic can be selected as follows:

1. CH1 Prime Mode - Switches from CH1 to the CH2 only if CH1 alarms and CH2 is good. Switches back when CH1 no longer in alarm or both CH1 and CH2 are bad.
2. Latch to CH2 Mode - Switches to CH2 if CH1 alarms and CH2 is good. Latches to CH2. Push Manual Reset or ground Remote Reset pin to return to CH1 if it has no alarm.
3. Minimum AUTO switching. Initial Channel Select (ICS) Mode - Switch stays on channel last selected by Manual or Remote selection after return to AUTO. AUTO switching occurs only if current channel alarms and other channel is clear.

When power is lost and when power is applied (as alarms at power up dictate), the selected channel remains on. The Manual Select switch and (when in AUTO) contact closures to Remote Select pins select CH1 or CH2 independent of alarms. LEDs indicate alarm and switch conditions for CH1 and CH2 and REMOTE or MANUAL operation. Redundant power supplies are provided.

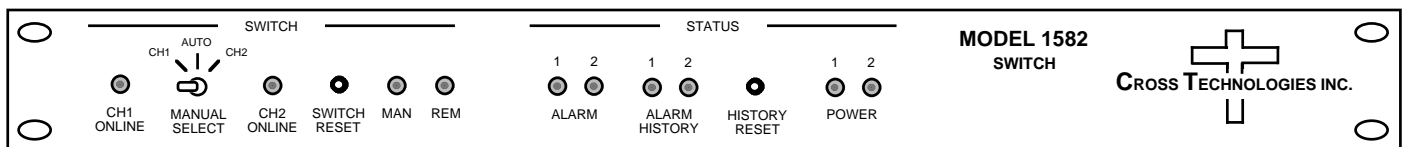

**1582-25L**

### EQUIPMENT SPECIFICATIONS\*

#### Switch Characteristics

Impedance	75Ω
Type/Configuration	Latching Relay, DPDT
Insertion Loss	1.5 dB max., ≤1.0 dB, typ, DC to 1.5 GHz 2.5 dB max., ≤2.0 dB, typ, 1.5 to 2.5 GHz
Frequency Response	±0.5 dB, any 40 MHz BW, DC to 2.5 GHz
Return Loss	≥12 dB max., ≥14 dB, typ, DC to 1.5 GHz ≥10 dB max., ≥12 dB, typ, 1.5 to 2.5 GHz
Isolation	-55 dB max., ≤-60 dB, typ, DC to 1.5 GHz -45 dB max., ≤-50 dB, typ, 1.5 to 2.5 GHz
Switch time	≤10 milliseconds
DC Switching	30VDC, max; 0.5 Amps, max

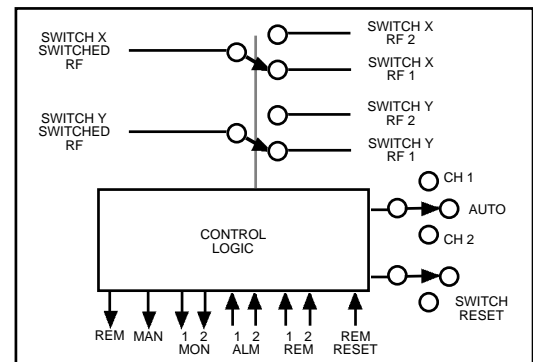

**1582-25L BLOCK DIAGRAM**

#### Controls and Indicators

Manual Select	Manually select CH1, CH2
SWITCH RESET	Resets to CH1 in latch mode, Also Resets REMOTE
HISTORY RESET	Resets alarm history (prior occurrence of alarms now cleared) LEDs only
LEDs (*=Closures)	CH1*, CH2* ON-LINE, ALARM, ALARM HISTORY, POWER; MANUAL*; REMOTE*

#### Other

Alarm/Remote Connector	Terminal Strip
RF Connectors	75Ω BNC (female); 50 Ω BNC, N Connectors, Optional
Mechanical	19 inch standard chassis 1.75"high X 12" deep
Power	Redundant power supplies; <b>100-240 ±10% VAC</b> , 47 -63 Hz, 30 watts

#### Available Options

W31	Extended Temperature Range Testing; 0° C to 50° C
W72	Alternate Switching Voltage; GP10, 2.7V, DC Trigger

\*10°C to 40°C; 2000m max elevation; 80% max humidity; Specifications subject to change without notice