

3116-80-2050 Block Downconverter, 8.0 - 8.5 GHz to 1.80 - 2.30 GHz

The 3116-80-2050 Downconverter converts 8.0 - 8.5 GHz to 1.80 - 2.30 GHz (non-inverted) with a 6.20 GHz local oscillator. The gain is +35 dB maximum and is adjustable in 0.5 ±0.5 dB steps. Front panel LEDs provide indication of Remote operation, PLL Alarm and DC Power. Gain and internal/external/Auto reference frequency selection are controlled by front panel switches or remote selection (via RS-232C/485, standard; Ethernet Optional) and are viewable on the LCD Display. Connectors are Type N female for the RF and BNC female for the L-Band and external reference input and reference output. In AUTO, the 10 MHz reference stays in external if the external level is +3 dBm, ±3 dB. The 3116 is powered by a 100-240 ± 10% VAC power supply, and housed in a 1 3/4" X 19" X 14" rack mount chassis.

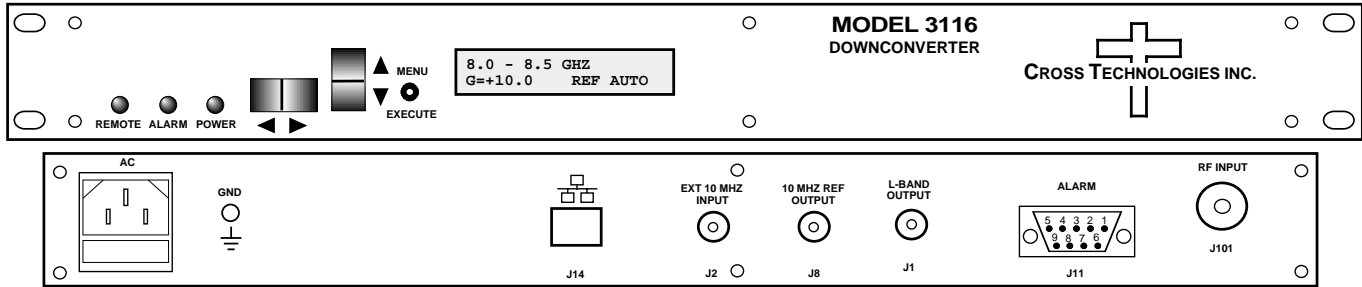

EQUIPMENT SPECIFICATIONS*

Input Characteristics (RF)

Impedance/Return Loss 50Ω/18 dB
 Frequency 8.0 to 8.5 GHz
 Noise Figure, Maximum 12 dB max gain
 Input Level range -55 to -35 dBm
 Input 1 dB compression -25 dBm

Output Characteristics

Impedance/Return Loss 50Ω /14 dB
 Frequency 1.80 to 2.30 GHz
 Output Level Range -20 to 0 dBm
 Output 1 dB compression +10 dBm at max. gain

Channel Characteristics

Gain, max; adjustment +35 dB ±2 dB, max. gain; 30 dB adjustment in **0.5± 0.5 dB** Steps
 Image Rejection > 60 dB, min
 Spurious, In Band SIGNAL RELATED<-55 dBC in band, 0 dBm out; SIGNAL INDEPENDENT, <-60 dBm (**1.80-2.30 GHz Out**)
 Spurious, Out of Band <-50 dBm (**1.3-1.79 GHz and 2.31-2.8 GHz Out**)
 Intermodulation <-55 dBC for two carriers each at -10 dBm out
 Frequency Response ±1.5 dB, **1800-2300** MHz out; ± 0.5 dB, 40 MHz BW
 Frequency Sense Non-inverting

LO Characteristics

LO Frequency 6.20 GHz
 Frequency Accuracy ± 0.01 ppm max over temp internal reference; ext. ref. input
 10 MHz In/Out Level 3 dBm, ± 3 dB, w/ Auto-detect

Phase Noise @ F (Hz) >	10	100	1K	10K	100K	1M
Standard dBC/Hz	-55	-70	-80	-85	-100	-110
Opt W87 Enhanced dBC/Hz	-60	-75	-90	-95	-105	-120

Controls, Indicators

Gain; Ext Ref Selection Direct readout LCD; pushbutton switches or remote
 Pwr; Alarm; Rem; Mute Green LED; Red LED; Yellow LED; Yellow LED
 Remote RS232C/RS485/422, 9600 baud (Ethernet Optional)

Other

RF Connector Type N (female), 50Ω
 L-Band Connector BNC (female), 50Ω
 10 MHz Connectors BNC (female), 75Ω, works with 50 or 75 ohms
 Alarm/Remote Conn. DB9 - NO or NC contact closure on Alarm
 Size 19 inch standard chassis 1.75" high X 14.0" deep
 Power 100-240 ± 10% VAC, 47 - 63 Hz, **30 watts** max.

Front and Rear Panel (shown with optional Ethernet)

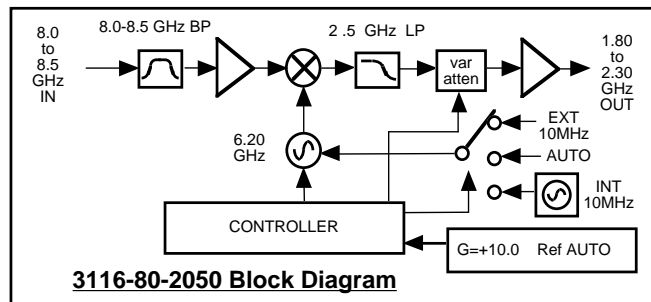

Available Options

W31 - 0 to +50 degrees C operation
 W87 - Enhanced Phase Noise

Remote M&C Ethernet Options

W8 - Ethernet w/web browser Interface
 W18 - Ethernet w/SNMP (and MIB) Interface
 W28 - Ethernet w/direct TCP/IP Interface

Connector Options

N - 50Ω N-type (RF), 75Ω BNC (L-BAND)
 NF - 50Ω N-type (RF), 75Ω F-type (L-BAND)
 NN - 50Ω N-type (RF), 50Ω N-type (L-BAND)
 S7 - 50Ω SMA (RF), 75Ω BNC (L-BAND)
 SF - 50Ω SMA (RF), 75Ω F-type (L-BAND)
 SN - 50Ω SMA (RF), 50Ω N-type (L-BAND)
 SS - 50Ω SMA (RF), 50Ω SMA (L-BAND)

Contact Cross for other options

*10°C to 40°C; Specifications subject to change without notice.