

# Instruction Manual

# Model 3116-5060#-2000

## Block Downconverter

March 2023, Rev. 0



Data, drawings, and other material contained herein are proprietary to Cross Technologies, Inc., but may be reproduced or duplicated without the prior permission of Cross Technologies, Inc. for purposes of operating the equipment. Printed in USA.

When ordering parts from Cross Technologies, Inc., be sure to include the equipment model number, equipment serial number, and a description of the part.



6170 Shiloh Road  
Alpharetta, Georgia 30005

(770) 886-8005  
FAX (770) 886-7964  
Toll Free 888-900-5588

WEB [www.crosstechnologies.com](http://www.crosstechnologies.com)  
E-MAIL [info@crosstechnologies.com](mailto:info@crosstechnologies.com)

# INSTRUCTION MANUAL

## MODEL 3116-5060#-2000 Block Downconverter

<u>TABLE OF CONTENTS</u>	<u>PAGE</u>
Warranty	2
<b>1.0 General</b>	<b>3</b>
1.1 Equipment Description	3
1.2 Technical Characteristics	4
1.3 Monitor & Control Interface	5
<b>2.0 Installation</b>	<b>8</b>
2.1 Mechanical	8
2.2 Rear I/O's	9
2.3 Front Panel Controls, Indicators	9
2.4 Operation	10
2.5 Menu Settings	11
<b>3.0 Environmental Use Information</b>	<b>16</b>

**WARRANTY** - The following warranty applies to all Cross Technologies, Inc. products.

All Cross Technologies, Inc. products are warranted against defective materials and workmanship for a period of one year after shipment to customer. Cross Technologies, Inc.'s obligation under this warranty is limited to repairing or, at Cross Technologies, Inc.'s option, replacing parts, subassemblies, or entire assemblies. Cross Technologies, Inc. shall not be liable for any special, indirect, or consequential damages. This warranty does not cover parts or equipment which have been subject to misuse, negligence, or accident by the customer during use. All shipping costs for warranty repairs will be prepaid by the customer. There are not other warranties, express or implied, except as stated herein.



6170 Shiloh Road  
Alpharetta, Georgia 30005

(770) 886-8005  
FAX (770) 886-7964  
Toll Free 888-900-5588

WEB [www.crosstechnologies.com](http://www.crosstechnologies.com)  
E-MAIL [info@crosstechnologies.com](mailto:info@crosstechnologies.com)

# MODEL 3116-5060#-2000 Block Downconverter

## 1.0 General

### 1.1 Equipment Description

The 3116-5060#-2000 Downconverter converts 5.00 - 6.00 GHz to 1.50 - 2.50 GHz (inverted) with a 7.50 GHz local oscillator. The gain is +25 dB maximum and is adjustable in  $0.5 \pm 0.5$  dB steps. Front panel LEDs provide indication of Remote operation, PLL Alarm and DC Power. Gain and internal/external/Auto reference frequency selection are controlled by front panel switches or remote selection (via RS-232C/485, standard; Ethernet Optional) and are viewable on the LCD Display. The connectors are Type N female for the RF and BNC female for the L-Band and external reference input and reference output. In AUTO, the 10 MHz reference stays in external if the external level is +3 dBm,  $\pm 3$  dB. It is powered by a 100-240  $\pm 10\%$  VAC power supply, and housed in a 1 3/4" X 19" X 14" rack mount chassis.

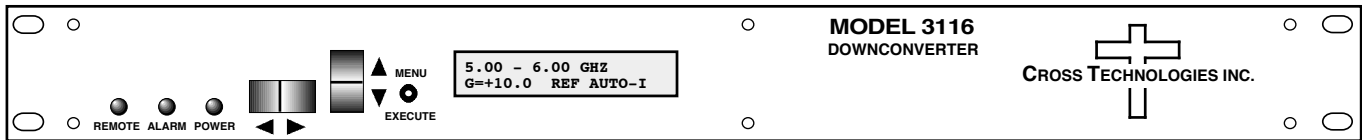

FRONT PANEL - 3116-5060#-2000

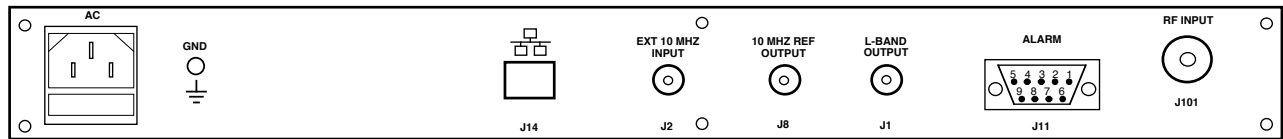

REAR PANEL - 3116-5060#-2000 (Shown with optional RJ45 Ethernet Connector)

**FIGURE 1.1 3116-5060#-2000 Front and Rear Panels**

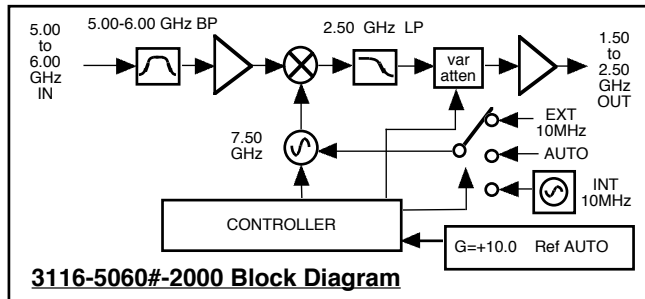

**FIGURE 1.2 3116-5060#-2000 Block Diagram**

## 1.2 Technical Characteristics

**TABLE 1.0 3116-5060#-2000 Block Downconverter Specifications\***

<b>Input Characteristics</b>						
Impedance / Return Loss	50Ω / 14 dB					
Frequency	5.00 to 6.00 GHz					
Noise Figure, Maximum	12 dB at max. gain, Fc					
Input Level Range	-45 to -25 dBm					
Input 1 dB Compression	-25 dBm at min. gain, Fc					
<b>Output Characteristics</b>						
Impedance / Return Loss	50Ω / 14 dB					
Frequency	1.50 to 2.50 GHz					
Output Level Range	-20 to 0 dBm, at Fc					
Output 1 dB Compression	+10 dBm at max. gain, Fc					
<b>Channel Characteristics</b>						
Gain, Max. (adjustment)	+25 dB ±2 dB, max. gain; 0 to 25.0 dB adjustment in 0.5 ±0.5 dB Steps					
Image Rejection	> 60 dB, min.					
Spurious, Inband	-50 dBc in band, 0 dBm out; (1.50 - 2.50 GHz Out), at max. gain					
Spurious, Out of Band	<-50 dBm (0.5-1.50 GHz and 2.50 - 3.50 GHz Out), at max. gain					
Intermodulation	<-50 dBc for two carriers spaced at Fc ± 2 MHz, each at -10 dBm out, at max. gain					
Frequency Reponse	±2.0 dB, 1.50 - 2.50 GHz out; ± 0.5 dB, 40 MHz BW					
Frequency Sense	Inverting					
<b>LO Characteristics</b>						
LO Frequencies	7.50 GHz					
Frequency Accuracy	±0.01 ppm maximum oven temperature internal reference; external reference input					
10 MHz Level In/Out	3 dBm, ± 3 dB, with Auto-detect					
<b>Phase Noise @ F (Hz) &gt;</b>	10	100	1K	10K	100K	1M
Standard dBC/(Hz)	-55	-60	-70	-80	-90	-110
<b>Controls, Indicators</b>						
Gain; Ext. Reference Selection	Direct Readout LCD; pushbutton switches or remote					
Power, Alarm, Remote, Mute	Green LED, Red LED, Yellow LED, Yellow LED					
Remote	RS232C/RS485/422, 9600 baud (Ethernet Optional)					
<b>Other</b>						
RF Connector	Type N (female), 50Ω					
L-Band Connector	BNC (female). 50Ω					
10 MHz Connectors	BNC (female). 75Ω works with 50 or 75 ohms					
Alarm / Remote Connector	DB9 - NO or NC Contact Closure on Alarm					
Size	19 inch, Standard Chassis, 1.75" high X 14.0" deep					
Power	100-240 ±10% VAC, 47-63 Hz, 30 watts maximum					
<b>Available Options</b>			<b>Remote M&amp;C Ethernet Options</b>			
W31 -	0 to +50 degrees C Operation		- W8	Ethernet with Web Browser Interface		
Available Connector Options, See Table 2.2, PG 9			- W18	Ethernet with SNMP (and MIB) Interface		
			- W28	Ethernet; with Direct TCP/IP Interface		

\*10°C to 40°C; Specifications subject to change without notice

### 1.3 Monitor and Control Interface

#### A) Remote Serial Interface

**Protocol:** RS-232C, 9600 baud rate, no parity, 8 data bits, 1 start bit, and 1 stop bit.  
(RS-232C, RS-422, or RS-485)

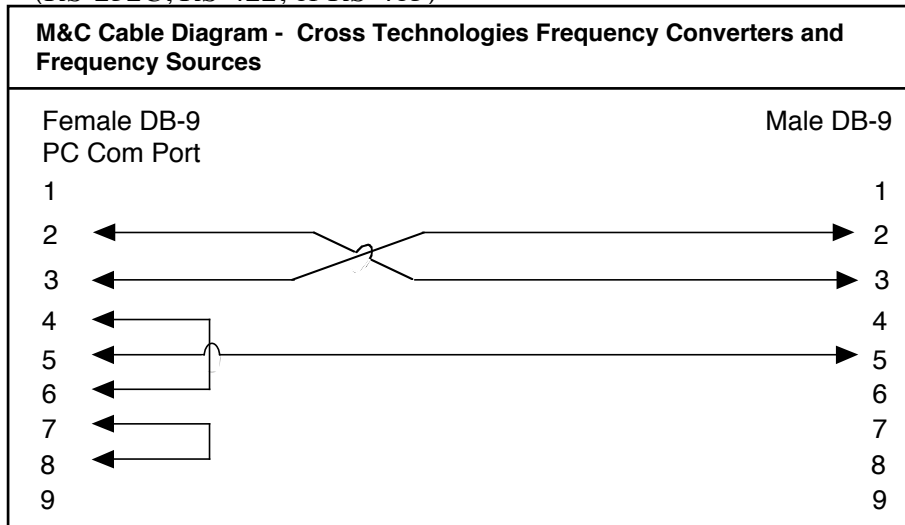

**Connector:** Rear panel, DB-9 male

J10 Pinouts (RS-232C/422/485)	
Pin	Function
1	Rx-
2	Rx+ (RS-232C)
3	Tx+ (RS-232C)
4	Tx-
5	GND
6	Alarm Relay: Common
7	Alarm Relay: Normally Open
8	Not Used
9	Alarm Relay: Normally Closed

**B) Status Requests** - Table 1.1 lists the status requests for the 3116-5060#-2000 and briefly describes them.

\* PLEASE NOTE: The two character {aa}(00-31) prefix, in the table below, should be used ONLY when RS-485 is selected.

<b>TABLE 1.1 3116-5060#-2000 Downconverter Status Requests</b>		
<b>Command</b>	<b>Syntax *</b>	<b>Description</b>
Get Gain	{aaSG}	returns {aaSGxxx} where: <ul style="list-style-type: none"> <li>• xxx = Converter gain in 0.5± 0.5 dB steps.</li> </ul>
Get Internal 10 MHz Reference Offset	{aaSO}	Returns {aaSOxxxxx} where: <ul style="list-style-type: none"> <li>• xxxxxx = Internal 10 MHz reference frequency offset.</li> </ul>
Get 10 MHz Reference Mode	{aaSE}	Returns {aaSEx} where: <ul style="list-style-type: none"> <li>• x = 0 if the converter's 10 MHz reference mode is set to Internal</li> <li>• x = 1 if the converter's 10 MHz reference mode is set to External</li> <li>• x = 2 if the converter's 10 MHz reference mode is set to Auto</li> </ul>
Get Mute	{aaSM}	Returns {aaSMx} where: <ul style="list-style-type: none"> <li>• x = 0 if the converter's RF output is NOT muted (RF output is ON)</li> <li>• x = 1 if the converter's RF output is muted (RF output is OFF)</li> </ul>
Get 10 MHz Reference Status	{aaSB}	Returns {aaSBx} where: <ul style="list-style-type: none"> <li>• x = 0 if the currently selected 10 MHz reference is Internal</li> <li>• x = 1 if the currently selected 10 MHz reference is External</li> </ul>
Get Summary Alarm Status	{aaSA}	Returns {aaSAx} where: <ul style="list-style-type: none"> <li>• x = 0 when there is no summary alarm condition</li> <li>• x = 1 if there is a summary alarm condition</li> </ul>
Get IP Address	{Si}	Returns {Sixxx.xxx.xxx.xxx} where: <ul style="list-style-type: none"> <li>• xxx.xxx.xxx.xxx = IP address</li> </ul>
Get Subnet Mask	{Ss}	Returns {Ssxxx.xxx.xxx.xxx} where: <ul style="list-style-type: none"> <li>• xxx.xxx.xxx.xxx = subnet mask</li> </ul>
Get Product/Model info	{Sv}	Returns {Sv3116-5060#-2000y..yverZZZ} where: <ul style="list-style-type: none"> <li>• 3116-xx is the product model number</li> <li>• y..y = list of options, if any</li> <li>• "ver" = separates model &amp; options from firmware version</li> <li>• ZZZZ = firmware version (e.g., 4.00)</li> </ul>

## C) Commands

Table 1.2 lists the commands for the 3116-5060#-2000 and briefly describes them.

After a command is sent the 3116 sends a return “>” indicating the command has been received and executed.

**General Command Format** - The general command format is {CND...}, where:

{ = start byte

C = 1 character, either C (command) or S (status)

N = 1 character command or status request

D = 1 character or more of data (depends on command)

} = stop byte

<b>TABLE 1.2 3116-5060#-2000 Downconverter Commands</b>		
<b>Command</b>	<b>Syntax *</b>	<b>Description</b>
Set Gain	{aaCGxxx}	where: <ul style="list-style-type: none"> <li>• xxx = Converter gain in 0.5 ±0.5 dB steps.</li> </ul> Range: 0 to 250 where 0 = 0.0 dB and 250 = 25.0 db Example: {CG155} sets the converter's gain to +15.5dB
Set Internal 10 MHz Reference Offset	{aaCOxxxxx}	where: <ul style="list-style-type: none"> <li>• xxxxxx = Internal 10 MHz reference frequency offset.</li> </ul> Range: -2000 to +2000
Set 10 MHz Reference Mode	{aaCEx}	where: <ul style="list-style-type: none"> <li>• x = 0 if the converter's 10 MHz reference mode is set to Internal</li> <li>• x = 1 if the converter's 10 MHz reference mode is set to External</li> <li>• x = 2 if the converter's 10 MHz reference mode is set to Auto</li> </ul>
Set Mute	{aaCMx}	where: <ul style="list-style-type: none"> <li>• x = 0 if the converter's RF output is NOT muted (RF output is ON)</li> <li>• x = 1 if the converter's RF output is muted (RF output is OFF)</li> </ul>

## 2.0 Installation

### 2.1 Mechanical

The 3116 is powered by a 100-240  $\pm$  10% VAC power supply, and housed in a 1 3/4" X 19" X 14" rack mount chassis. The 3116-5060#-2000 can be secured to a rack using the 4 holes on the front panel. Figure 2.0 shows how the 3116-5060#-2000 is assembled.

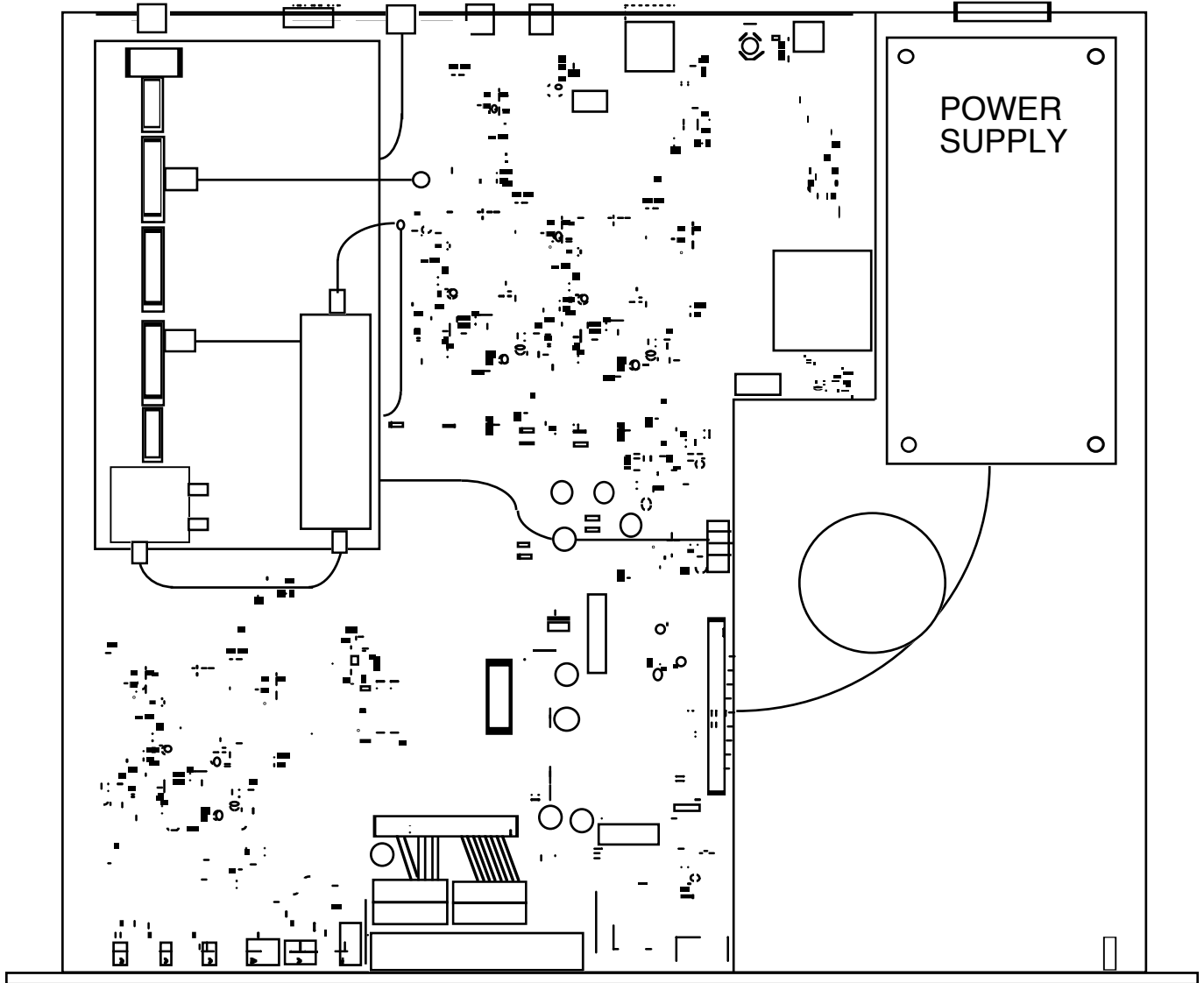
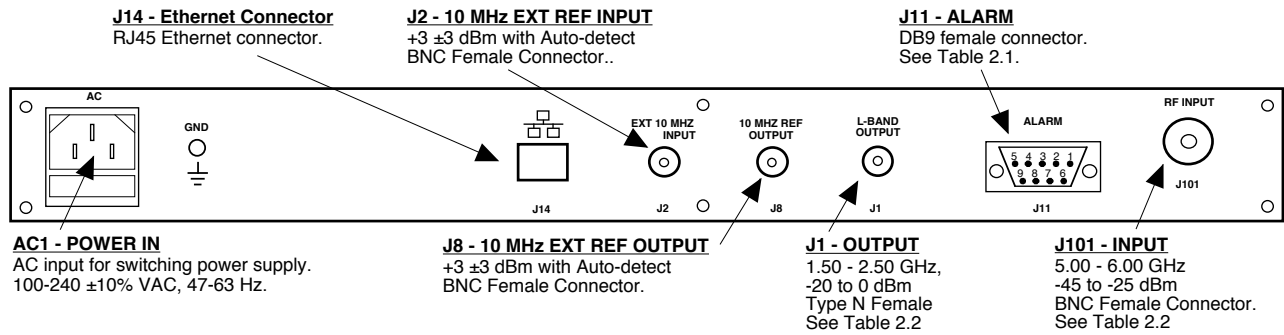

**FIGURE 2.0 3116-5060#-2000 Mechanical Assembly**



## 2.2 Rear Panel Input/Output Signals

Figure 2.1 shows the input and output connectors on the rear panel.



**FIGURE 2.1 3116-5060#-2000 Rear Panel I/O's**

TABLE 2.1 J10 Pinouts*	
Pin	Function
1	Rx-
2	Rx+ (RS-232C)
3	Tx+ (RS-232C)
4	Tx-
5	GND
6	Alarm Relay: Common
7	Alarm Relay: Normally Open
8	Not Used
9	Alarm Relay: Normally Closed

TABLE 2.2 Connector Options		
Option	RF	L-Band
-N	50Ω Type N	75Ω BNC
-NF	50Ω Type N	75Ω Type N
-NN	50Ω Type N	50Ω Type N
-S7	50Ω SMA	75Ω BNC
-SF	50Ω SMA	75Ω Type N
-SN	50Ω SMA	50Ω Type N
-SS	50Ω SMA	50Ω SMA

### \*Remote Serial Interface

Interface: DB-9 Male Protocol: RS-232C (RS-232C/422/485),  
9600 baud rate, no parity, 8 data bits, 1 start bit, 1 stop bit.

## 2.3 Front Panel Controls and Indicators

Figure 2.2 shows the front panel controls and indicators.

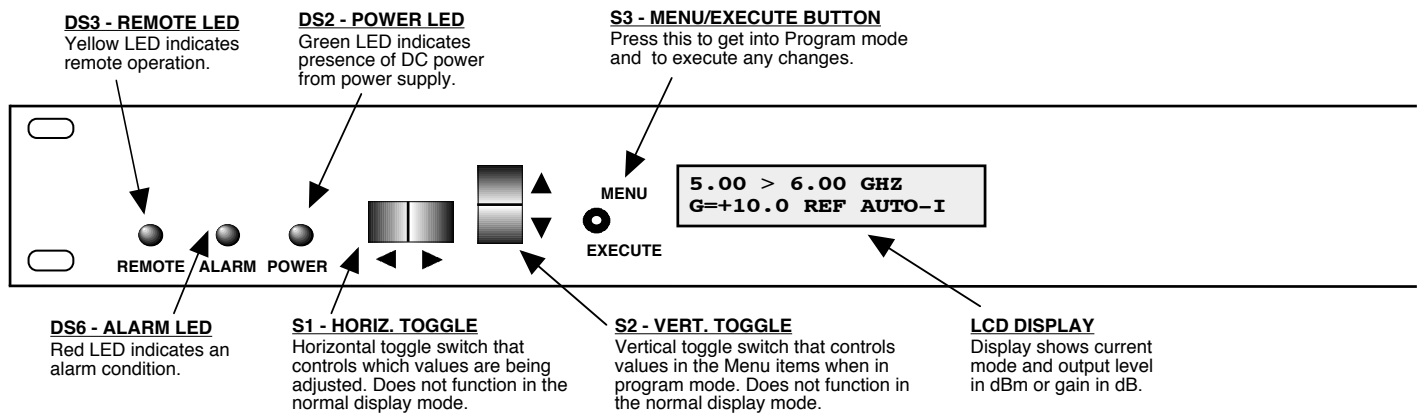
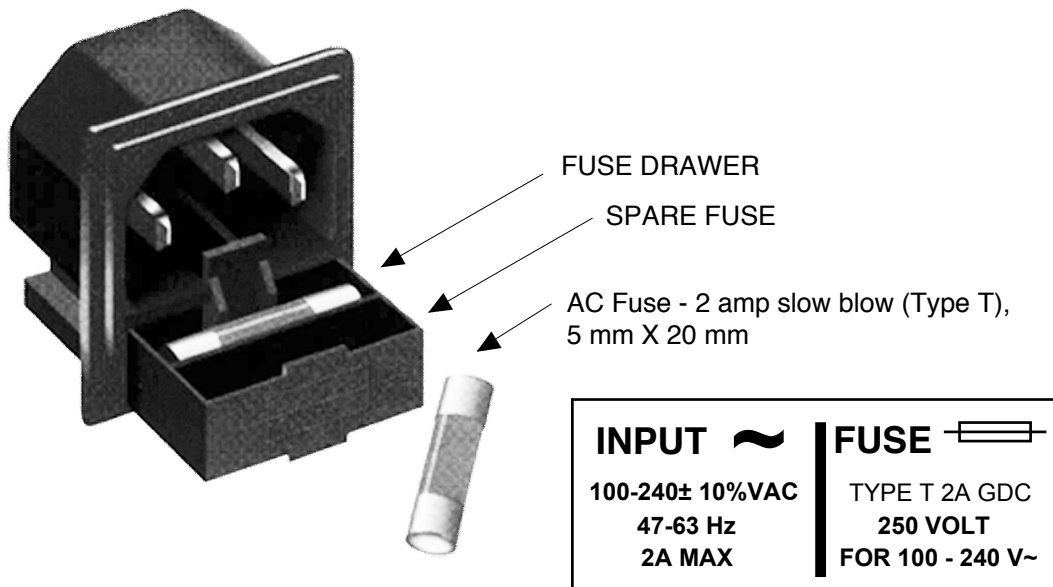

**FIGURE 2.2 3116-5060#-2000 Front Panel Controls and Indicators**

## 2.4 Installation / Operation

### 2.4.1 Installing and Operating the 3116-5060#-2000

1. Connect a -45 dBm to -25 dBm signal to RF IN, J1 (Figure 2.1).
2. Connect the RF OUT, J101, to the external equipment.
3. Connect 100-240  $\pm$ 10% VAC, 47 - 63 Hz to AC connector on the back panel.
4. Set the gain (from 0 to +25.0, 0.5 dB steps) for the desired output level.xxxxx  
Make sure the output stays within -20 to 0 dBm with the gain.  
selected and the input level provided. (See Section 2.5 Menu Settings).
5. Be sure DS2 (green, DC Power) is on and DS6 (red, Alarm) is off (Figure 2.2).
6. AC Fuse - The fuse is a 5 mm X 20 mm, 2 amp slow blow (Type T) and is inserted in the far slot in the drawer below the AC input as shown in Figure 2.3. There is a spare fuse in the near slot.  
If a fuse continues to open, the power supply is most likely defective.



**FIGURE 2.3 Fuse Location and Spare Fuse**

## 2.5 Menu Settings

### 2.5.1 Functions

This section describes operation of the front panel controls. There are three operator switches, the LCD display and alarm indicator LEDs. All functions for the equipment are controlled by these components. The functions are (See Figure 2.4):

#### Power Up

#### Normal Display

<b>Menu 1</b>	Set Gain
<b>Menu 2</b>	Set Mute
<b>Menu 3</b>	Set Reference Mode
<b>Menu 4</b>	Set Reference Offset
<b>Menu 5</b>	Set Remote
<b>Menu 6</b>	Set Remote Interface
<b>Menu 7</b>	Set RS-485 Address

**Save Menu** When “R” is selected from any above menu or at the end.

Alarm indications appear on the LEDs (see Figure 2.2).

All program changes must start with the operation of the Menu/Execute switch and must also end with the operation of the Menu/Execute switch verified by the “Save Settings?” Menu. If this sequence is not followed, none of the changes will take effect. If programming is initiated and no operator action takes place for approximately 30 seconds (before the final press of the Menu/Execute switch) the display will revert to its previous status and you will need to start over.

## 2.5.2. Power On Settings

**NOTE: THE LAST OPERATING PARAMETERS OF A UNIT ARE RETAINED EVEN WHEN POWER IS REMOVED. WHEN POWER IS RESTORED, THE UNIT WILL RETURN TO IT'S PREVIOUS SETTINGS.**

When power is first applied, the LCD display goes through three steps.

1. The LCD goes black to show all segments are functioning.
2. The Model and Software version will be displayed.

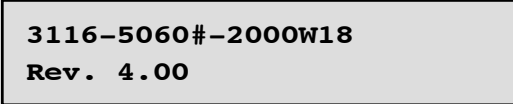

**3116-5060#-2000w18  
Rev. 4.00**

3. The present frequency and gain of the downconverter is shown.



**5.00 > 6.00 GHz  
G = +10 REF AUTO -I**

The unit is now operational and ready for any changes the operator may desire.

## 2.5.3 Control Switches

1. Menu/Execute - Any change to the programming of the unit must be initiated by pressing the Menu/Execute switch and completed by pressing the Menu/Execute switch.
2. Horizontal Switch - This switch is mounted so its movement is horizontal and moves the display cursor left or right.
3. Vertical Switch - This switch is mounted so its movement is vertical and has two functions:
  - a. During gain changes, the vertical movement will raise or lower the number in the direction of the arrows.
  - b. For other functions such Remote on/off, the vertical switch will alternately turn the function on or off regardless of the direction operated.

## 2.5.4 Gain Changes

When you get to this menu note that gain changes will be made as you make them but if you do not wish to save the changes you have made, scroll to **“R”** and push the menu/Execute switch and select **“NO”** in the **“SAVE SETTINGS?”** window or **do not press the Menu/Execute switch**; simply do nothing for approximately 30 seconds, and the system will return to the normal operating mode.

**NOTE: THE GAIN WILL CHANGE AS YOU ADJUST THE NUMBERS. HOWEVER, THE VALUE WILL NOT BE STORED UNTIL YOU INDICATE YES IN THE SAVE SETTINGS WINDOW. DO NOT SET A GAIN THAT WOULD EXCEED 0 dBm OR HAVE LESS THAN -20 dBm OUTPUT LEVEL.**

Press the Up/Down switch to change the gain in 0.5, 1, or 10 dB steps and then push the Menu/Execute switch to get to the Save Settings Menu:

<b>GAIN = +17.5</b>	<b>R</b>
---------------------	----------

When the display indicates the value desired you can push the Menu/Execute switch to the next item OR you can scroll to **“R”**, push the Menu/Execute switch to get to:

<b>SAVE SETTINGS?</b>	<b><u>Y</u> N</b>
-----------------------	-------------------

Selecting **Y** will save the new settings. Selecting **N** will revert to the previous settings.

Figure 2.4 (page 15) gives the menu items and how to make changes.

## 2.5.5 Alarm Indications

An alarm condition will occur if any local oscillator phase lock loop (PLL) comes out of lock. The Remote LED will light when you select the Remote mode.

## 2.5.6 10 MHz Reference Mode Operation

**Internal Mode:** The unit uses its own built-in 10 MHz OCXO. The Internal Reference is present on the Reference Output Connector, J8. REF = INT appears on the front panel display.

**External Mode:** The unit uses a 10 MHz Reference that is connected to the External Reference Input, J2. REF = EXT appears on the front panel display. The External 10 MHz Reference level must be +3dBm,  $\pm 3$ dB. If the External 10 MHz signal does not meet the unit's specified parameters then the unit will not function properly. The External Reference is present on the Reference Output connector, J8.

**Auto Mode:** The unit defaults to the External 10 MHz Reference as long as the level meets the +3dBm,  $\pm 3$ dB specification. REF = AUTO - E appears on the front panel display where the -E indicates that the unit is using the External 10 MHz Reference. The External Reference is present on the Reference Output connector, J8.

If the external 10 MHz Reference signal level is less than -1dBm, the unit switches to Internal 10 MHz Reference. REF = AUTO -I appears on the front panel display where -I indicates that the unit is using the Internal 10 MHz Reference. The Internal 10 MHz Reference is present on the reference output connector, J8.

	<b>ON POWER UP (1)</b>			
<b>Power Up 1:</b>	=== IP Addr === 192.168.123.002			
	<b>ON POWER UP (2)</b>			
<b>Power Up 2:</b>	3116-5060#-2000W18 4.0			
	<hr/>			
	<b>NORMAL DISPLAY</b>			
<b>Normal Display</b>	5.00 > 6.00 GHZ G = +10.0 REF AUTO-I			PUSH BUTTON
	<hr/>			
	<b>PUSHING MENU/EXECUTE SEQUENCE</b>			
<b>Menu 1</b> Set Gain	GAIN = 15.5	R	SCROLL <> SCROLL <>	PUSH BUTTON
<b>Menu 2</b> Set Mute	MUTE = ON	R	SCROLL <> SCROLL <>	PUSH BUTTON
<b>Menu 3</b> Set Reference Mode	REF MODE = AUTO	R	SCROLL <> SCROLL <>	PUSH BUTTON
<b>Menu 4</b> Set Reference Offset	INTERNAL FREQ ADJUST OFFSET = -1225	R	SCROLL <> SCROLL <>	PUSH BUTTON
<b>Menu 5</b> Set Remote	REMOTE = ON	R	SCROLL <> SCROLL <>	PUSH BUTTON
<b>Menu 6</b> Set Remote Interface	INTERFACE = RS232	R	SCROLL <> SCROLL <>	PUSH BUTTON
<b>Menu 7</b> Set RS485 Address	RS485 ADDRESS = 0	R	SCROLL <> SCROLL <>	PUSH BUTTON
<b>Save?</b> When go to end	SAVE SETTINGS? Y N		SCROLL <> SCROLL <>	PUSH BUTTON

**FIGURE 2.4 Menu Display and Sequences**

### 3.0 Environmental Use Information

- A. **Rack-Mounting** - To mount this equipment in a rack, please refer to the installation instructions located in the user manual furnished by the manufacturer of your equipment rack.
- B. **Mechanical Loading** - Mounting of equipment in a rack should be such that a hazardous condition does not exist due to uneven weight distribution.
- C. **Elevated Operating Ambient Temperature** - If installed in a closed or multi-unit rack assembly, the operating ambient temperature of the rack may be greater than room ambient temperature. Therefore, consideration should be given to Tmra.
- D. **Reduced Air Flow** - Installation of the equipment in a rack should be such that the amount of air flow required for safe operation of the equipment is not compromised. Additional space between units may be required.
- E. **Circuit Overloading** - Consideration should be given to the connection of the equipment to the supply circuit and the effect that overloading of circuits could have on over current protection and supply wiring. Appropriate consideration of equipment name plate rating should be used when addressing this concern.
- F. **Reliable Earthing** - Reliable earthing of rack-mounted equipment should be maintained. Particular attention should be given to supply connections other than direct connection to the Branch (use of power strips).
- G. **Top Cover** - There are no serviceable parts inside the product so, the Top Cover should not be removed. If the Top Cover is removed the ground strap and associated screw **MUST BE REINSTALLED** prior to Top Cover screw replacement. **FAILURE TO DO** this may cause **INGRESS** and/or **EGRESS** emission problems.





6170 Shiloh Road  
Alpharetta, Georgia 30005

(770) 886-8005  
FAX (770) 886-7964  
Toll Free 888-900-5588

WEB [www.crosstechnologies.com](http://www.crosstechnologies.com)  
E-MAIL [info@crosstechnologies.com](mailto:info@crosstechnologies.com)

Printed in USA

