

Instruction Manual

Model 3116-137

Block Downconverter

October, Rev. 0

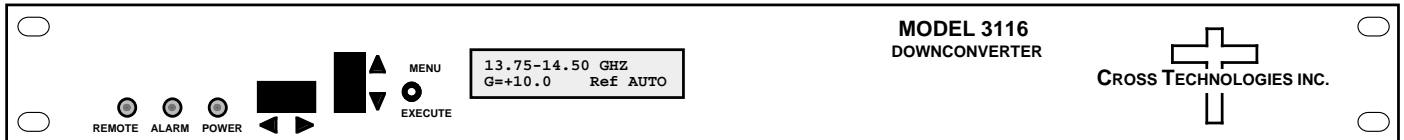

Data, drawings, and other material contained herein are proprietary to Cross Technologies, Inc., but may be reproduced or duplicated without the prior permission of Cross Technologies, Inc. for purposes of operating the equipment. Printed in USA.

When ordering parts from Cross Technologies, Inc., be sure to include the equipment model number, equipment serial number, and a description of the part.



6170 Shiloh Road
Alpharetta, Georgia 30005

(770) 886-8005
FAX (770) 886-7964
Toll Free 888-900-5588

WEB www.crosstechnologies.com
E-MAIL info@crosstechnologies.com

INSTRUCTION MANUAL

MODEL 3116-137 Block Downconverter

<u>TABLE OF CONTENTS</u>	<u>PAGE</u>
Warranty	2
1.0 General	3
1.1 Equipment Description	3
1.2 Technical Characteristics	4
1.3 Monitor & Control Interface	6
2.0 Installation	9
2.1 Mechanical	9
2.2 Rear I/O's	10
2.3 Front Panel Controls, Indicators	10
2.4 Operation	11
2.5 Menu Settings	12
3.0 Environmental Use Information	18

WARRANTY - The following warranty applies to all Cross Technologies, Inc. products.

All Cross Technologies, Inc. products are warranted against defective materials and workmanship for a period of one year after shipment to customer. Cross Technologies, Inc.'s obligation under this warranty is limited to repairing or, at Cross Technologies, Inc.'s option, replacing parts, subassemblies, or entire assemblies. Cross Technologies, Inc. shall not be liable for any special, indirect, or consequential damages. This warranty does not cover parts or equipment which have been subject to misuse, negligence, or accident by the customer during use. All shipping costs for warranty repairs will be prepaid by the customer. There are not other warranties, express or implied, except as stated herein.



6170 Shiloh Road
Alpharetta, Georgia 30005

(770) 886-8005
FAX (770) 886-7964
Toll Free 888-900-5588

WEB www.crosstechnologies.com
E-MAIL info@crosstechnologies.com

MODEL 3116-137 Downconverter

1.0 General

1.1 Equipment Description

The 3116-137 Downconverter converts 13.75 - 14.50 GHz to 0.95 - 1.7 GHz with low phase noise and flat frequency response. Frequency translation is via a 12.80 GHz local oscillator. The gain is +35 dB maximum and is adjustable in 1 dB steps. Front panel LEDs provide indication of Remote operation, PLL Alarm and DC Power. Gain and internal/external/Auto reference frequency selection are controlled by front panel switches or remote selection (via RS 232C, standard; Ethernet Optional) and are viewable on the LCD Display. Connectors are SMA female for the RF and BNC female for the L-Band and external reference input and reference output. In AUTO, the 10 MHz reference switches to internal when the external is below 0 dBm ± 1 dB. The 3116 is powered by a 100-240 ± 10% VAC power supply, and housed in a 1 3/4" X 19" X 14" rack mount chassis.

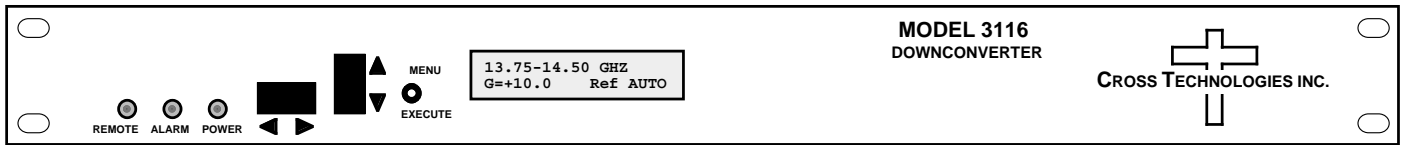

FRONT PANEL - 3116-137

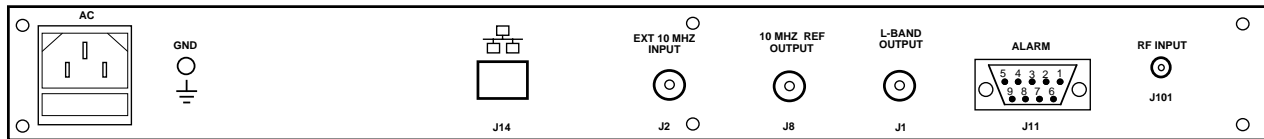

REAR PANEL - 3116-137 (Shown with Optional RJ45 Ethernet Connector)

FIGURE 1.1 3116-137 Front and Rear Panels

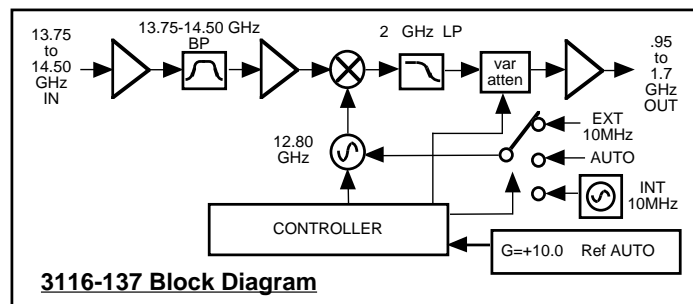

FIGURE 1.2 3116-137 Block Diagram

1.2 Technical Characteristics

TABLE 1.0 3116-137 Block Downconverter Specifications*

Input Characteristics (RF)					
Impedance / Return Loss	50Ω / 14 dB				
Frequency	13.75 to 14.50 GHz				
Noise Figure, Maximum	12 dB maximum gain (higher with Option W67)				
Input Level Range	-55 to -35 dBm (-55 to 0, Option W67)				
Input 1 dB Compression	-25 dBm (+10 minimum gain, Option W57)				
Output Characteristics (L-Band)					
Impedance / Return Loss	50Ω / 14 dB				
Frequency	0.95 to 1.7 GHz				
Output Level Range	-20 to 0 dBm				
Output 1 dB Compression	+10 dBm at maximum gain				
Channel Characteristics					
Gain, Maximum (adjustment)	+35 dB ±2 dB, maximum gain; 30 dB adjustment in 1 dB steps				
Image Rejection	> 60 dB, minimum				
Spurious, Inband	SIGNAL RELATED <-55 dBC in band, 0 dBm out; 2XFo <-45dBC; SIGNAL INDEPENDENT, <-60 dBm				
Spurious, Out of Band	<-50 dBm, 0.5 - 0.95 GHz and 1.70 - 2.5 GHz				
Intermodulation	<-55 dBC for two carriers each at -10 dBm out				
Frequency Response	±1.5 dB, 950 - 1700 MHz out, ±0.5 dB, 40 MHz BW				
Frequency Sense	Non-inverting				
LO Characteristics					
LO Frequency	12.80 GHz				
Frequency Accuracy	±0.01 ppm maximum over temp internal reference; external reference input				
10 MHz Level In/Out	3 dBm, ± 3 dB, with Auto-detect				
Phase Noise @ F (Hz) >	100	1K	10K	100K	1M
Standard dBC/(Hz)	-70	-80	-85	-100	-110
Controls, Indicators					
Freq; Gain; Ext. Ref. Selection	Direct Readout LCD; pushbutton switches or remote				
Power; Alarm; Remote	Green LED, Red LED, Yellow LED, Yellow LED				
Remote	RS232C/RS485/422, 9600 baud (Ethernet Optional)				

*10°C to 40°C; Specifications subject to change without notice

Technical Characteristics continued on page 5...

Technical Characteristics continued from page 4..

Other			
RF/ L-Band Connector		SMA (female), 50Ω	
10 MHz Connectors		BNC (female), 75Ω works with 50 or 75 ohm	
Alarm / Remote Connector		DB9 - NO or NC Contact Closure on Alarm	
Size		19 inch, Standard Chassis, 1.75" high X 14.0" deep	
Power		100-24 ±10% VAC, 47-63 Hz, 30 watts maximum	
Connector Options		Remote M&C Ethernet Options	
- N	50Ω N-type (RF), 75Ω BNC (L-BAND)	- W8	Ethernet with Web Browser Interface
- NN	50Ω N-type (RF), 50Ω N-type (L-BAND)	- W18	Ethernet with SNMP (and MIB) Interface
- S7	50Ω SMA (RF), 75Ω BNC (L-BAND)	- W28	Ethernet with Direct TCP/IP Interface
- SN	50Ω SMA (RF), 50Ω N-type (L-BAND)	Extended Temperature Option	
- SS	50Ω SMA (RF), 50Ω SMA (L-BAND)	- W31	0°C to 50°C
Contact Cross Technologies for other options.		Other Options	
		- W67 - Extends input level to -55 to 0dBm Contact Cross for gain and noise figure implications with this option.	

1.3 Monitor and Control Interface

A) Remote Serial Interface

Protocol: RS-232C, 9600 baud rate, no parity, 8 data bits, 1 start bit, and 1 stop bit.
(RS-232C, RS-422, or RS-485)

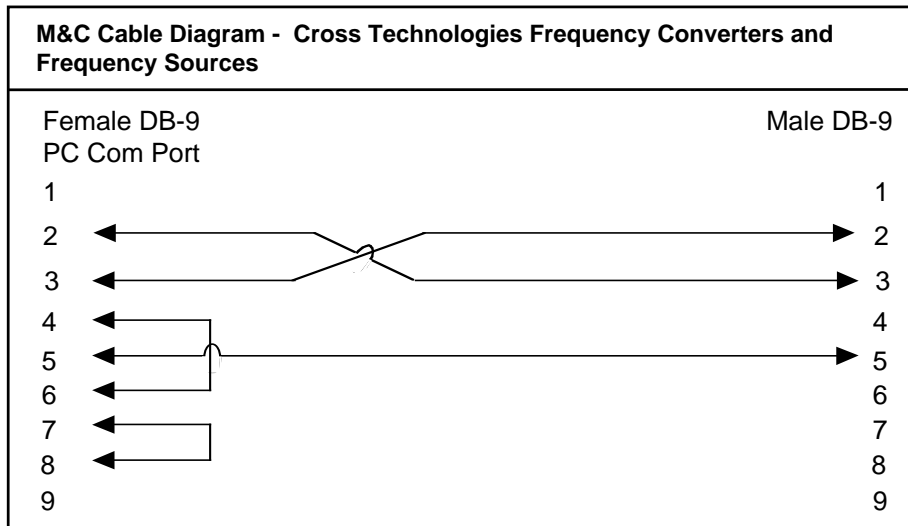

Connector: Rear panel, DB-9 male

J10 Pinouts (RS-232C/422/485)	
Pin	Function
1	Rx-
2	Rx+ (RS-232C)
3	Tx+ (RS-232C)
4	Tx-
5	GND
6	Alarm Relay: Common
7	Alarm Relay: Normally Open
8	Not Used
9	Alarm Relay: Normally Closed

B) Status Requests - Table 1.1 lists the status requests for the 3116-137 and briefly describes them.

* PLEASE NOTE: The two character {aa}(00-31) prefix, in the table below, should be used ONLY when RS-485 is selected.

TABLE 1.1 3116-137 Downconverter Status Requests		
Command	Syntax *	Description
Get Gain	{aaSG}	returns {aaSGxxxx} where: <ul style="list-style-type: none"> • xxxx = Converter gain in 1 dB steps
Get Internal 10 MHz Reference Offset	{aaSO}	Returns {aaSOxxxxx} where: <ul style="list-style-type: none"> • xxxxxx = Internal 10 MHz reference frequency offset.
Get 10 MHz Reference Mode	{aaSE}	Returns {aaSEx} where: <ul style="list-style-type: none"> • x = 0 if the converter's 10 MHz reference mode is set to Internal • x = 1 if the converter's 10 MHz reference mode is set to External • x = 2 if the converter's 10 MHz reference mode is set to Auto
Get Mute	{aaSM}	Returns {aaSMx} where: <ul style="list-style-type: none"> • x = 0 if the converter's RF output is NOT muted (RF output is ON) • x = 1 if the converter's RF output is muted (RF output is OFF)
Get 10 MHz Reference Status	{aaSB}	Returns {aaSBx} where: <ul style="list-style-type: none"> • x = 0 if the currently selected 10 MHz reference is Internal • x = 1 if the currently selected 10 MHz reference is External
Get Summary Alarm Status	{aaSA}	Returns {aaSAx}where: <ul style="list-style-type: none"> • x = 0 when there is no summary alarm condition • x = 1 if there is a summary alarm condition
Get IP Address <i>Ethernet Option Only</i>	{Si}	Returns {aaSixxx.xxx.xxx.xxx} where: <ul style="list-style-type: none"> • xxx.xxx.xxx.xxx = IP address
Get Subnet Mask <i>Ethernet Option Only</i>	{Ss}	Returns {aaSsxxx.xxx.xxx.xxx} where: <ul style="list-style-type: none"> • xxx.xxx.xxx.xxx = subnet mask
Get Product/Model info	{SV}	Returns {aaSV3116-137y..yverZZZZ} where: <ul style="list-style-type: none"> • 3116-xx is the product model number • y..y = list of options, if any • ""ver" = separates model & options from firmware version • ZZZZ = firmware version (e.g., 4.00)
Get Inpt Level range (option W67)	{aaSI}	Returns {aaSIx} where: <ul style="list-style-type: none"> • x = A for input level range = -55 to-35 dBm • x = B for input level range = -40 to-20 dBm • x = C for input level range = -20 to 0 dBm

C) Commands

Table 1.2 lists the commands for the 3116 and briefly describes them.

After a command is sent the 3116 sends a return “>” indicating the command has been received and executed.

General Command Format - The general command format is {CND...}, where:

{ = start byte

C = 1 character, either C (command) or S (status)

N = 1 character command or status request

D = 1 character or more of data (depends on command)

} = stop byte

* PLEASE NOTE: The two character {aa}(00-31) prefix, in the table below, should be used ONLY when RS-485 is selected.

TABLE 1.2 3116-137 Downconverter Commands		
Command	Syntax *	Description
Set Gain	{aaCGxxx}	where:
		• xxx = Converter gain in 1 dB steps.
		Range: 050 to 350 where 050 = 5.0 dB and 350 = 35.0 db
		Example: {CG150} sets the converter's gain to +15 dB
		NOTE: If option W67 is installed then the available gain range depends on the currently selected input level (see section 2.5.7).
		• Input level range A (-55 to -35dBm): gain range = +15.0 to +35.0
		• Input level range B (-40 to -20dBm): gain range = +5.0 to +35.0
		• Input level range C (-20 to 0dBm): gain range = 0 to +20.0
Set Internal 10 MHz Reference Offset	{aaCOxxxxx}	where:
		• xxxxxx = Internal 10 MHz reference frequency offset.
		Range: -2000 to +2000
Set 10 MHz Reference Mode	{aaCEx}	where:
		• x = 0 if the converter's 10 MHz reference mode is set to Internal
		• x = 1 if the converter's 10 MHz reference mode is set to External
		• x = 2 if the converter's 10 MHz reference mode is set to Auto
Set Mute	{aaCMx}	where:
		• x = 0 if the converter's RF output is NOT muted (RF output is ON)
		• x = 1 if the converter's RF output is muted (RF output is OFF)
Set Input Level Range (option W67)	{aaClx}	where:
		• x = A for input level range = -55 to -35 dBm
		• x = B for input level range = -40 to -20 dBm
		• x = C for input level range = -20 to 0 dBm

2.0 Installation

2.1 Mechanical

The 3116 is powered by a 100-240 \pm 10% VAC power supply, and housed in a 1 3/4" X 19" X 14" rack mount chassis. The 3116 can be secured to a rack using the 4 holes on the front panel. Figure 2.0 shows how the 3116 is assembled.

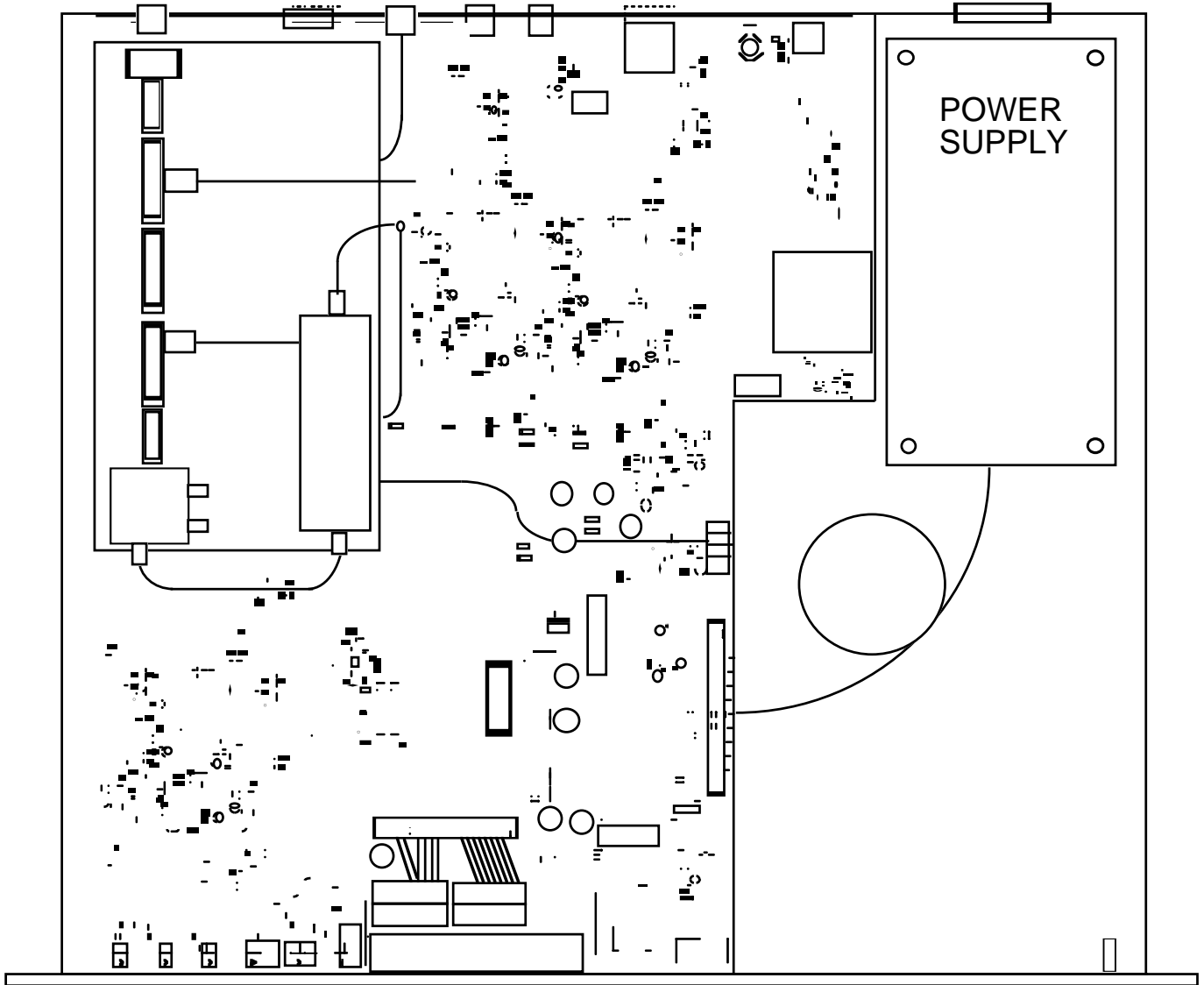

FIGURE 2.0 3116-137 Mechanical Assembly

2.2 Rear Panel Input/Output Signals

Figure 2.1 shows the input and output connectors on the rear panel.

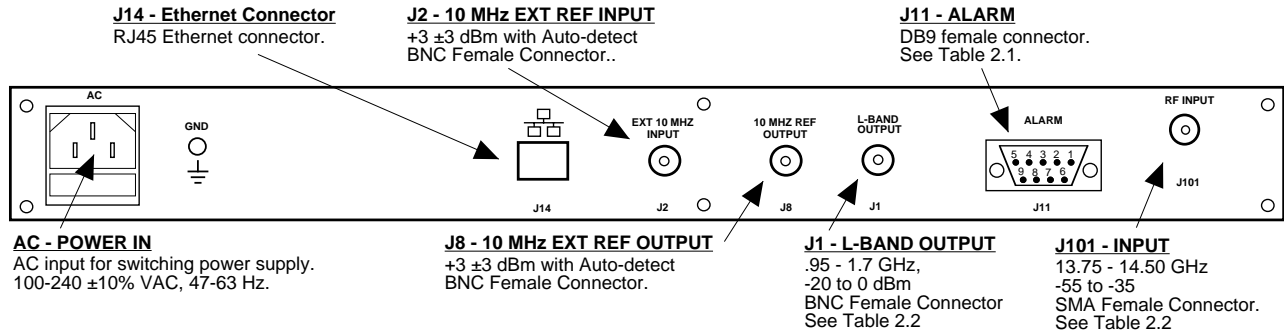

FIGURE 2.1 3116-137 Rear Panel I/O's

TABLE 2.1 J10 Pinouts*	
Pin	Function
1	Rx-
2	Rx+ (RS-232C)
3	Tx+ (RS-232C)
4	Tx-
5	GND
6	Alarm Relay: Common
7	Alarm Relay: Normally Open
8	Not Used
9	Alarm Relay: Normally Closed

TABLE 2.2 Connector Options		
Option	RF	L-Band
-N	50Ω Type N	75Ω BNC
-NN	50Ω Type N	50Ω Type N
-S7	50Ω SMA	75Ω BNC
-SF	50Ω SMA	75Ω Type N
-SN	50Ω SMA	50Ω Type N
-SS	50Ω SMA	50Ω SMA

*Remote Serial Interface

Interface: DB-9 Male Protocol: RS-232C (RS-232C/422/485),
9600 baud rate, no parity, 8 data bits, 1 start bit, 1 stop bit.

2.3 Front Panel Controls and Indicators

Figure 2.2 shows the front panel controls and indicators.

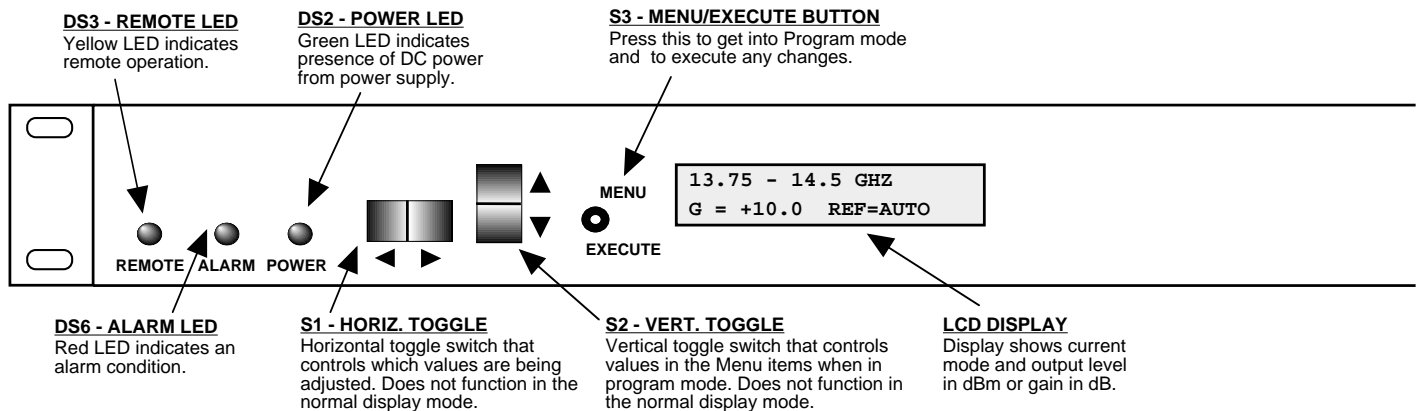

FIGURE 2.2 3116-137 Front Panel Controls and Indicators

2.4 Installation / Operation

2.4.1 Installing and Operating the 3116-137

1. Connect a -55 dBm to -35 dBm signal to RF IN, J101 (Figure 2.1).
2. Connect the RF OUT, J1, to the external equipment.
3. Connect 100-240 \pm 10% VAC, 47 - 63 Hz to AC connector on the back panel.
4. Set the gain +35 dB maximum, adjustable in 1 dB steps.
5. Make sure the output stays within -20 to 0 dBm with the gain selected and the input level provided. (See Section 2.5 Menu Settings).
6. Be sure DS2 (green, DC Power) is on and DS6 (red, Alarm) is off (Figure 2.2).
7. AC Fuse - The fuse is a 5 mm X 20 mm, 2 amp slow blow (Type T) and is inserted in the far slot in the drawer below the AC input as shown in Figure 2.3. There is a spare fuse in the near slot. If a fuse continues to open, the power supply is most likely defective.

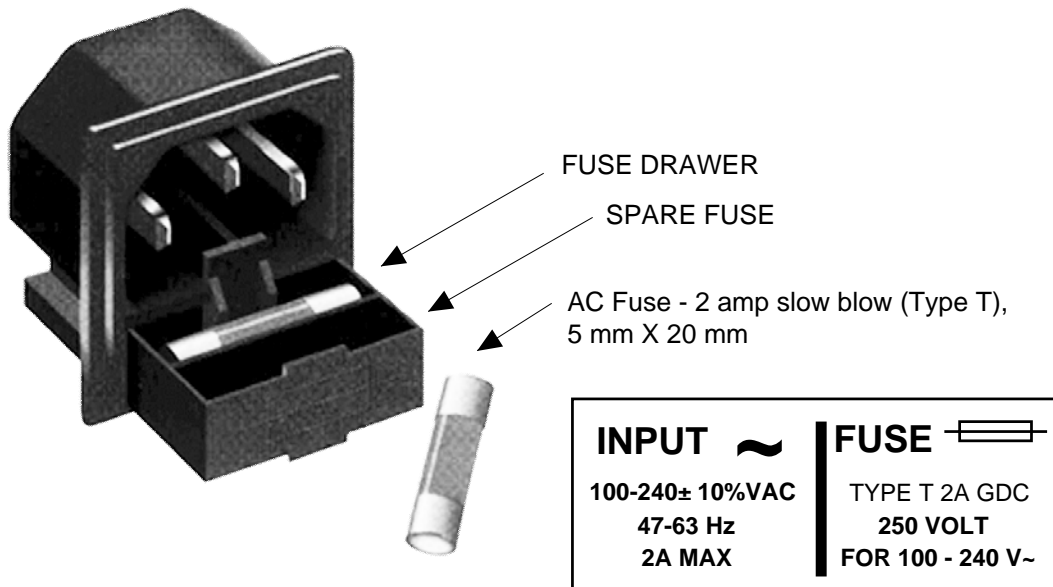

FIGURE 2.3 Fuse Location and Spare Fuse

2.5 Menu Settings

2.5.1 Functions

This section describes operation of the front panel controls. There are three operator switches, the LCD display and alarm indicator LEDs. All functions for the equipment are controlled by these components. The functions are (See Figure 2.4):

Power Up

Normal Display

Menu 1	Set Input Level Range (option W67 only).
Menu 2	Set Gain
Menu 3	Set Mute
Menu 4	Set Reference Mode
Menu 5	Set Reference Offset
Menu 6	Set Remote
Menu 7	Set Remote Interface
Menu 8	Set RS-485 Address

Save Menu When “R” is selected from any above menu or at the end.

Alarm indications appear on the LEDs (see Figure 2.2).

All program changes must start with the operation of the Menu/Execute switch and must also end with the operation of the Menu/Execute switch verified by the “Save Settings?” Menu. If this sequence is not followed, none of the changes will take effect. If programming is initiated and no operator action takes place for approximately 30 seconds (before the final press of the Menu/Execute switch) the display will revert to its previous status and you will need to start over.

2.5.2. Power On Settings

NOTE: THE LAST OPERATING PARAMETERS OF A UNIT ARE RETAINED EVEN WHEN POWER IS REMOVED. WHEN POWER IS RESTORED, THE UNIT WILL RETURN TO IT'S PREVIOUS SETTINGS.

When power is first applied, the LCD display goes through three steps.

1. The LCD goes black to show all segments are functioning.
2. The Model and Software version will be displayed.

```
3116-137W18  
Rev. 1.00
```

3. The present frequency and gain of the downconverter is shown.

```
13.75 - 14.5 GHz  
G = +10.0 REF=AUTO
```

The unit is now operational and ready for any changes the operator may desire.

2.5.3 Control Switches

1. Menu/Execute - Any change to the programming of the unit must be initiated by pressing the Menu/Execute switch and completed by pressing the Menu/Execute switch.
2. Horizontal Switch - This switch is mounted so its movement is horizontal and moves the display cursor left or right.
3. Vertical Switch - This switch is mounted so its movement is vertical and has two functions:
 - a. During gain changes, the vertical movement will raise or lower the number in the direction of the arrows.
 - b. For other functions such Remote on/off, the vertical switch will alternately turn the function on or off regardless of the direction operated.

2.5.4 Gain Changes

When you get to this menu note that gain changes will be made as you make them but if you do not wish to save the changes you have made, scroll to **“R”** and push the menu/Execute switch and select **“NO”** in the **“SAVE SETTINGS?”** window or **do not press the Menu/Execute switch**; simply do nothing for approximately 30 seconds, and the system will return to the normal operating mode.

NOTE: THE GAIN WILL CHANGE AS YOU ADJUST THE NUMBERS. HOWEVER, THE VALUE WILL NOT BE STORED UNTIL YOU INDICATE YES IN THE SAVE SETTINGS WINDOW. DO NOT SET A GAIN THAT WOULD EXCEED 0 dBm OR HAVE LESS THAN -20 dBm OUTPUT LEVEL.

Press the Up/Down switch to change the gain in 1, 1, or 10 dB steps and then push the Menu/Execute switch to get to the Save Settings Menu:

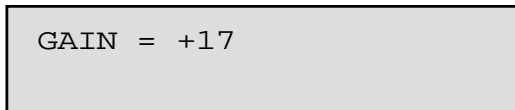

A rectangular box with a black border containing the text "GAIN = +17".

When the display indicates the value desired you can push the Menu/Execute switch to the next item OR you can scroll to **“R”**, push the Menu/Execute switch to get to:

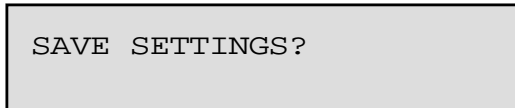

A rectangular box with a black border containing the text "SAVE SETTINGS?".

Selecting **Y** will save the new settings. Selecting **N** will revert to the previous settings.

Figure 2.4 (page 15) gives the menu items and how to make changes.

2.5.5 Alarm Indications

An alarm condition will occur if any local oscillator phase lock loop (PLL) comes out of lock. The Remote LED will light when you select the Remote mode.

2.5.6 10 MHz Reference Mode Operation

Internal Mode: The unit uses its own built-in 10 MHz OCXO. The Internal Reference is present on the Reference Output Connector, J8. REF = INT appears on the front panel display.

External Mode: The unit uses a 10 MHz Reference that is connected to the External Reference Input, J2. REF = EXT appears on the front panel display. The External 10 MHz Reference level must be +3dBm, ± 3 dB. If the External 10 MHz signal does not meet the unit's specified parameters then the unit will not function properly. The External Reference is present on the Reference Output connector, J8.

Auto Mode: The unit defaults to the External 10 MHz Reference as long as the level meets the +3dBm, ± 3 dB specification. REF = AUTO - E appears on the front panel display where the -E indicates that the unit is using the External 10 MHz Reference. The External Reference is present on the Reference Output connector, J8.

If the external 10 MHz Reference signal level is less than -1dBm, the unit switches to Internal 10 MHz Reference. REF = AUTO -I appears on the front panel display where -I indicates that the unit is using the Internal 10 MHz Reference. The Internal 10 MHz Reference is present on the reference output connector, J8.

2.5.7 Option W67 Extended Input Level Range

Option W67 extends the RF input level range from: -55 to -35 dBm to: -55 to 0 dBm.

The user must select one of the 3 input ranges which are:

- A.** -55 to -35 dBm
- B.** -40 to -20 dBm
- C.** -20 to -0 dBm

The option has a gain adjustable attenuator before the standard input amplifier. This attenuator/amp before the mixer provides a gain of +25, +10, or -10 dB respectively into the RF mixer. The noise figures for the three ranges are +10, +20 and >35 respectively for the three settings. Each range has a 0.5 +/- 0.5 dB step gain adjustment over the range. The specified operational output range remains -20 to 0 dBm (P1db of +10 dBm at maximum gain). The following table describes the input/output ranges, gain, P1db and noise figure implications with this option.

Range Letter	Level Range (dBm)	Gain Range (dB)	P1dB (dBm)	Noise Figure (dB)
A	-55 to -35	15 to 35	-25	10
B	-40 to -20	5 to 35	-10	20
C	-20 to 0	0 to 20	+10	> 35

The currently selected input range (A, B, or C as described above) is shown in the upper left hand corner of the main display as shown below.

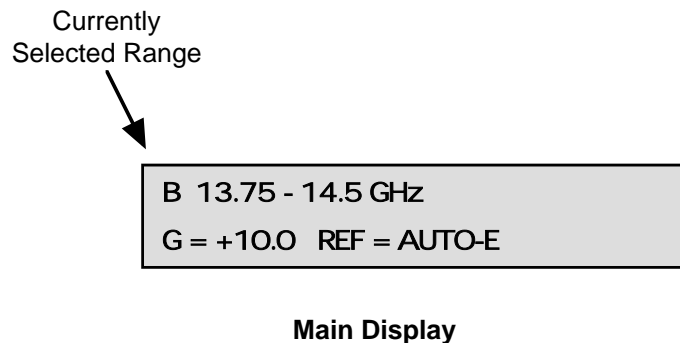

	ON POWER UP (1)		
Power Up 1:	=== IP Addr === 192.168.123.002		
	ON POWER UP (2)		
Power Up 2:	3116-137W18 1.0		
<hr/>			
	NORMAL DISPLAY		
Normal Display	13.75 -14.50 GHZ G = +10.0 REF=AUTO		PUSH BUTTON
<hr/>			
	PUSHING MENU/EXECUTE SEQUENCE		
Menu 1 Set Input Level Range (option W67 only)	INPUT LEVEL RANGE = R A -55 to -35 dBm	SCROLL <> SCROLL ⤴	PUSH BUTTON
Menu 2 Set Gain	GAIN = 15.0 R	SCROLL <> SCROLL ⤴	PUSH BUTTON
Menu 3 Set Mute	MUTE = ON R	SCROLL <> SCROLL ⤴	PUSH BUTTON
Menu 4 Set Reference Mode	REF MODE = AUTO R	SCROLL <> SCROLL ⤴	PUSH BUTTON
Menu 5 Set Reference Offset	INTERNAL FREQ ADJUST OFFSET = -1225 R	SCROLL <> SCROLL ⤴	PUSH BUTTON
Menu 6 Set Remote	REMOTE = ON R	SCROLL <> SCROLL ⤴	PUSH BUTTON
Menu 7 Set Remote Interface	INTERFACE = RS232 R	SCROLL <> SCROLL ⤴	PUSH BUTTON
Menu 8 Set RS485 Address	RS485 ADDRESS = 0 R	SCROLL <> SCROLL ⤴	PUSH BUTTON
Save? When go to end	SAVE SETTINGS? Y N	SCROLL <> SCROLL ⤴	PUSH BUTTON

FIGURE 2.4 Menu Display and Sequences

3.0 Environmental Use Information

- A. Rack-Mounting** - To mount this equipment in a rack, please refer to the installation instructions located in the user manual furnished by the manufacturer of your equipment rack.
- B. Mechanical Loading** - Mounting of equipment in a rack should be such that a hazardous condition does not exist due to uneven weight distribution.
- C. Elevated Operating Ambient Temperature** - If installed in a closed or multi-unit rack assembly, the operating ambient temperature of the rack may be greater than room ambient temperature. Therefore, consideration should be given to Tmra (Maximum Recommended Ambient Temperature).
- D. Reduced Air Flow** - Installation of the equipment in a rack should be such that the amount of air flow required for safe operation of the equipment is not compromised. Additional space between units may be required.
- E. Circuit Overloading** - Consideration should be given to the connection of the equipment to the supply circuit and the effect that overloading of circuits could have on over current protection and supply wiring. Appropriate consideration of equipment name plate rating should be used when addressing this concern.
- F. Reliable Earthing** - Reliable earthing of rack-mounted equipment should be maintained. Particular attention should be given to supply connections other than direct connection to the Branch (use of power strips).
- G. Top Cover** - There are no serviceable parts inside the product so, the Top Cover should not be removed. If the Top Cover is removed the ground strap and associated screw **MUST BE REINSTALLED** prior to Top Cover screw replacement. **FAILURE TO DO** this may cause **INGRESS** and/or **EGRESS** emission problems.



6170 Shiloh Road
Alpharetta, Georgia 30005

(770) 886-8005
FAX (770) 886-7964
Toll Free 888-900-5588

WEB www.crosstechnologies.com
E-MAIL info@crosstechnologies.com

Printed in USA