

Instruction Manual

Model 3115-145-1600

Block Upconverter

July 2017, Rev. A



Data, drawings, and other material contained herein are proprietary to Cross Technologies, Inc., but may be reproduced or duplicated without the prior permission of Cross Technologies, Inc. for purposes of operating the equipment. Printed in USA.

When ordering parts from Cross Technologies, Inc., be sure to include the equipment model number, equipment serial number, and a description of the part.



6170 Shiloh Road
Alpharetta, Georgia 30005

(770) 886-8005
FAX (770) 886-7964
Toll Free 888-900-5588

WEB www.crosstechnologies.com
E-MAIL info@crosstechnologies.com

INSTRUCTION MANUAL

MODEL 3115-145-1600 Block Upconverter

<u>TABLE OF CONTENTS</u>	<u>PAGE</u>
Warranty	2
1.0 General	3
1.1 Equipment Description	3
1.2 Technical Characteristics	4
1.3 Monitor & Control Interface	6
2.0 Installation	8
2.1 Mechanical	8
2.2 Rear I/O's	10
2.3 Front Panel Controls, Indicators	10
2.4 Operation	11
2.5 Menu Settings	12
3.0 Environmental Use Information	17

WARRANTY - The following warranty applies to all Cross Technologies, Inc. products.

All Cross Technologies, Inc. products are warranted against defective materials and workmanship for a period of one year after shipment to customer. Cross Technologies, Inc.'s obligation under this warranty is limited to repairing or, at Cross Technologies, Inc.'s option, replacing parts, subassemblies, or entire assemblies. Cross Technologies, Inc. shall not be liable for any special, indirect, or consequential damages. This warranty does not cover parts or equipment which have been subject to misuse, negligence, or accident by the customer during use. All shipping costs for warranty repairs will be prepaid by the customer. There are not other warranties, express or implied, except as stated herein.



6170 Shiloh Road
Alpharetta, Georgia 30005

(770) 886-8005
FAX (770) 886-7964
Toll Free 888-900-5588

WEB www.crosstechnologies.com
E-MAIL info@crosstechnologies.com

MODEL 3115-145-1600 Block Upconverter

1.0 General

1.1 Equipment Description

The 3115-145-1600 Upconverter converts 1.18 - 2.02 GHz (1600 ± 420 MHz) to 14.58 - 15.42 GHz ($F_c = 15.0$ GHz) (non-inverted) with a 13.4 GHz local oscillator. The maximum gain is +20 dB (adjustable in 0.5 ± 0.5 dB steps). Front panel LEDs provide indication of Remote operation, PLL Alarm and DC Power. Gain and internal/external/Auto reference frequency selection are controlled by front panel switches or remote selection (via RS-232C/485, standard; Ethernet Optional) and are viewable on the LCD Display. Connectors are SMA female for the RF and BNC female for the L-Band and external reference input and reference output. In AUTO, the 10 MHz reference stays in external if the external level is +3 dBm, ± 3 dB. It is powered by a 100-240 \pm 10% VAC power supply, and in a 1 3/4" X 19" X 14" rack mount chassis.



FRONT PANEL - 3115-145-1600

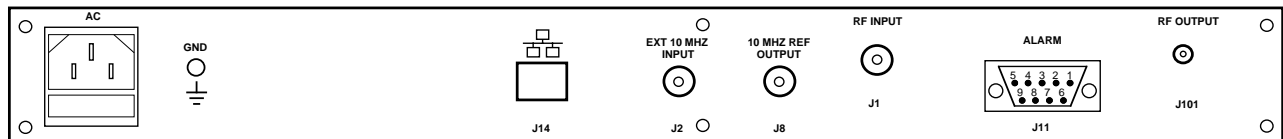

REAR PANEL - 3115-145-1600 (Shown with optional RJ45 Ethernet Connector)

FIGURE 1.1 3115-145-1600 Front and Rear Panels

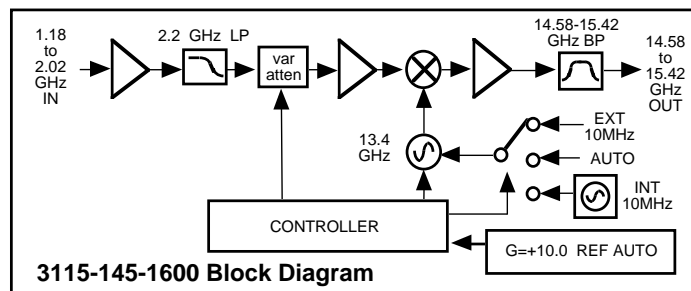

FIGURE 1.2 3115-145-1600 Block Diagram

1.2 Technical Characteristics

TABLE 1.0 3115-145-1600 Block Upconverter Specifications*

Input Characteristics					
Impedance / Return Loss	50Ω / 14 dB				
Frequency	1.18 to 2.02 GHz				
Output Level Range	-20 to -5 dBm				
Input Level Range	-40 to -25 dBm				
Output Characteristics					
Impedance / Return Loss	50Ω / 14 dB				
Frequency	14.58 to 15.42 GHz				
Output Level Range	-20 to -5 dBm				
Output 1 dB Compression	+5 dBm at maximum gain				
Channel Characteristics					
Gain, Max. (adjustment)	+20 dB ±2 dB, max. gain at Fc; 20 dB adjustment in 0.5 ±0.5 dB Steps				
Image Rejection	> 60 dB, minimum				
Spurious, Inband	SIGNAL RELATED<-60 dBC in band, -5dBm out; SIGNAL INDEPENDENT,<-60 dBm				
Spurious, Out of Band	<-50 dBm, 13.0 to 14.57 and 15.43 to 16.5GHz				
Intermodulation	<-50 dBC for two carriers each at -10 dBm out, GAIN = +20 dB				
Frequency Response	±1.5 dB, 14.58 -15.42 GHz out; ± 0.5 dB, 40 MHz BW				
Frequency Sense	Non-inverting				
LO Characteristics					
LO Frequency	13.4 GHz, Fixed LO				
Frequency Accuracy	±0.01 ppm maximum oven temperature internal reference; external reference input				
10 MHz Level In/Out	3 dBm, ± 3 dB, with Auto-detect				
Phase Noise @ F (Hz) >	100	1K	10K	100K	1M
Standard dBC/(Hz)	-70	-80	-85	-100	-110
Controls, Indicators					
Gain; Ext. Reference Selection	Direct Readout LCD; pushbutton switches or remote				
Power, Alarm, Remote	Green LED, Red LED, Yellow LED, Yellow LED				
Remote	RS232C/RS485/422, 9600 baud (Ethernet Optional)				
Other					
RF Connector	SMA (female), 50Ω				
L-Band Connector	BNC (female), 50Ω				
10 MHz Connectors	BNC (female), 75Ω works with 50 or 75 ohms				
Alarm / Remote Connector	DB9 - NO or NC Contact Closure on Alarm				
Size	19 inch, Standard Chassis, 1.75" high X 14.58" deep				
Power	100-24 ±10% VAC, 47-63 Hz, 45 watts maximum				

*10 degrees C to +40 degrees C; Specifications subject to change without notice.

Technical Specifications continued on page 5...

Technical Characteristics continued from page 4...

Available Options	
W31 -	0 to +50 degrees C Operation
Available Connector Options, See Table 2.2, PG 9	
Remote M&C Ethernet Options	
- W8	Ethernet with Web Browser Interface
- W18	Ethernet with SNMP (and MIB) Interface
- W28	Ethernet; with Direct TCP/IP Interface
Available Connector Options	
N -	50Ω N-Type (RF), 75Ω BNC (L-Band)
NN -	50Ω N-Type (RF), 50Ω N-Type (L-Band)
S7 -	50Ω SMA (RF), 75Ω BNC (L-Band)
SN -	50Ω SMA (RF), 50Ω N-Type (L-Band)
SS -	50Ω SMA (RF), 50Ω SMA (L-Band)
Available Connector Options, See Table 2.2, PG 9	

1.3 Monitor and Control Interface

A) Remote Serial Interface

Protocol: RS-232C, 9600 baud rate, no parity, 8 data bits, 1 start bit, and 1 stop bit.
(RS-232C, RS-422, or RS-485 - **option Q**)

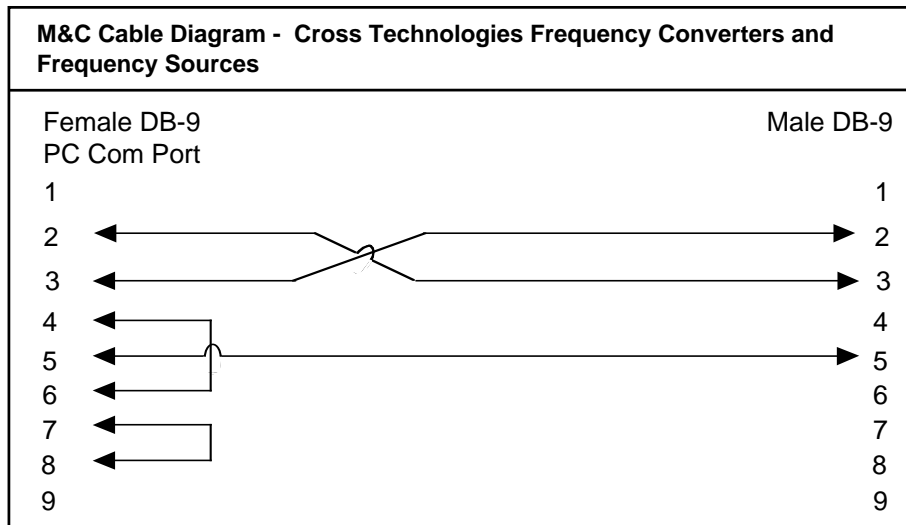

Connector: Rear panel, DB-9 male

J10 Pinouts (RS-232C/422/485)	
Pin	Function
1	Rx-
2	Rx+ (RS-232C)
3	Tx+ (RS-232C)
4	Tx-
5	GND
6	Alarm Relay: Common
7	Alarm Relay: Normally Open
8	Not Used
9	Alarm Relay: Normally Closed

B) Status Requests - Table 1.1 lists the status requests for the 3115-145-1600 and briefly describes them.

* PLEASE NOTE: The two character {aa}(00-31) prefix, in the table below, should be used ONLY when RS-485, (OPTION-Q), is selected.

TABLE 1.1 3115-145-1600 Status Requests		
Command	Syntax *	Description
Get Gain	{aaSG}	returns {aaSGxxxx} where: <ul style="list-style-type: none"> • xxxx = Converter gain in 0.5 dB steps
Get Internal 10 MHz Reference Offset	{aaSO}	Returns {aaSOxxxxx} where: <ul style="list-style-type: none"> • xxxxxx = Internal 10 MHz reference frequency offset.
Get 10 MHz Reference Mode	{aaSE}	Returns {aaSEx} where: <ul style="list-style-type: none"> • x = 0 if the converter's 10 MHz reference mode is set to Internal • x = 1 if the converter's 10 MHz reference mode is set to External • x = 2 if the converter's 10 MHz reference mode is set to Auto
Get Mute	{aaSM}	Returns {aaSMx} where: <ul style="list-style-type: none"> • x = 0 if the converter's RF output is NOT muted (RF output is ON) • x = 1 if the converter's RF output is muted (RF output is OFF)
Get 10 MHz Reference Status	{aaSB}	Returns {aaSBx} where: <ul style="list-style-type: none"> • x = 0 if the currently selected 10 MHz reference is Internal • x = 1 if the currently selected 10 MHz reference is External
Get IP Address Options W8, W18, W28 only)	{Si}	Returns {Sixxx.xxx.xxx.xxx} where: <ul style="list-style-type: none"> • xxx.xxx.xxx.xxx = IP address
Get Subnet Mask Options W8, W18, W28 only)	{Ss}	Returns {Ssxxx.xxx.xxx.xxx} where: <ul style="list-style-type: none"> • xxx.xxx.xxx.xxx = subnet mask
Get Product/Model info	{SV}	Returns {SV3115-145-1600y..yverZZZZ} where: <ul style="list-style-type: none"> • 3115-xx is the product model number • y..y = list of options, if any • ""ver" = separates model & options from firmware version • ZZZZ = firmware version (e.g., 4.00)
Get Alarm Status	{aaSA}	Returns {aaSAx}where: <ul style="list-style-type: none"> • x = 0 if alarm is off • x = 1 if alarm is on

C) Commands

Table 1.2 lists the commands for the 3115-145-1600 and briefly describes them.

After a command is sent the 3115 sends a return “>” indicating the command has been received and executed.

General Command Format - The general command format is {CND...}, where:

{ = start byte

C = 1 character, either C (command) or S (status)

N = 1 character command or status request

D = 1 character or more of data (depends on command)

} = stop byte

* PLEASE NOTE: The two character {aa}(00-31) prefix, in the table below, should be used ONLY when RS-485, (OPTION-Q), is selected.

TABLE 1.2 3115-145-1600 Commands		
Command	Syntax *	Description
Set Gain	{aaCGxxx}	where:
		• xxx = Converter gain in 0.5 ±0.5 dB steps.
		Range: 000 to 200 where 200 = 20.0 dB
		Example: {CG155} sets the converter's gain to +15.5dB
Set Internal 10 MHz Reference Offset	{aaCOxxxxx}	where:
		• xxxxxx = Internal 10 MHz reference frequency offset.
		Range: -2000 to +2000
Set 10 MHz Reference Mode	{aaCEx}	where:
		• x = 0 if the converter's 10 MHz reference mode is set to Internal
		• x = 1 if the converter's 10 MHz reference mode is set to External
		• x = 2 if the converter's 10 MHz reference mode is set to Auto
Set Mute	{aaCMx}	where:
		• x = 0 if the converter's RF output is NOT muted (RF output is ON)
		• x = 1 if the converter's RF output is muted (RF output is OFF)

2.0 Installation

2.1 Mechanical

The 3115 is powered by a 100-240 \pm 10% VAC power supply, and housed in a 1 3/4" X 19" X 14" rack mount chassis. The 3115-145-1600 can be secured to a rack using the 4 holes on the front panel. Figure 2.0 shows how the 3115-145-1600 is assembled.

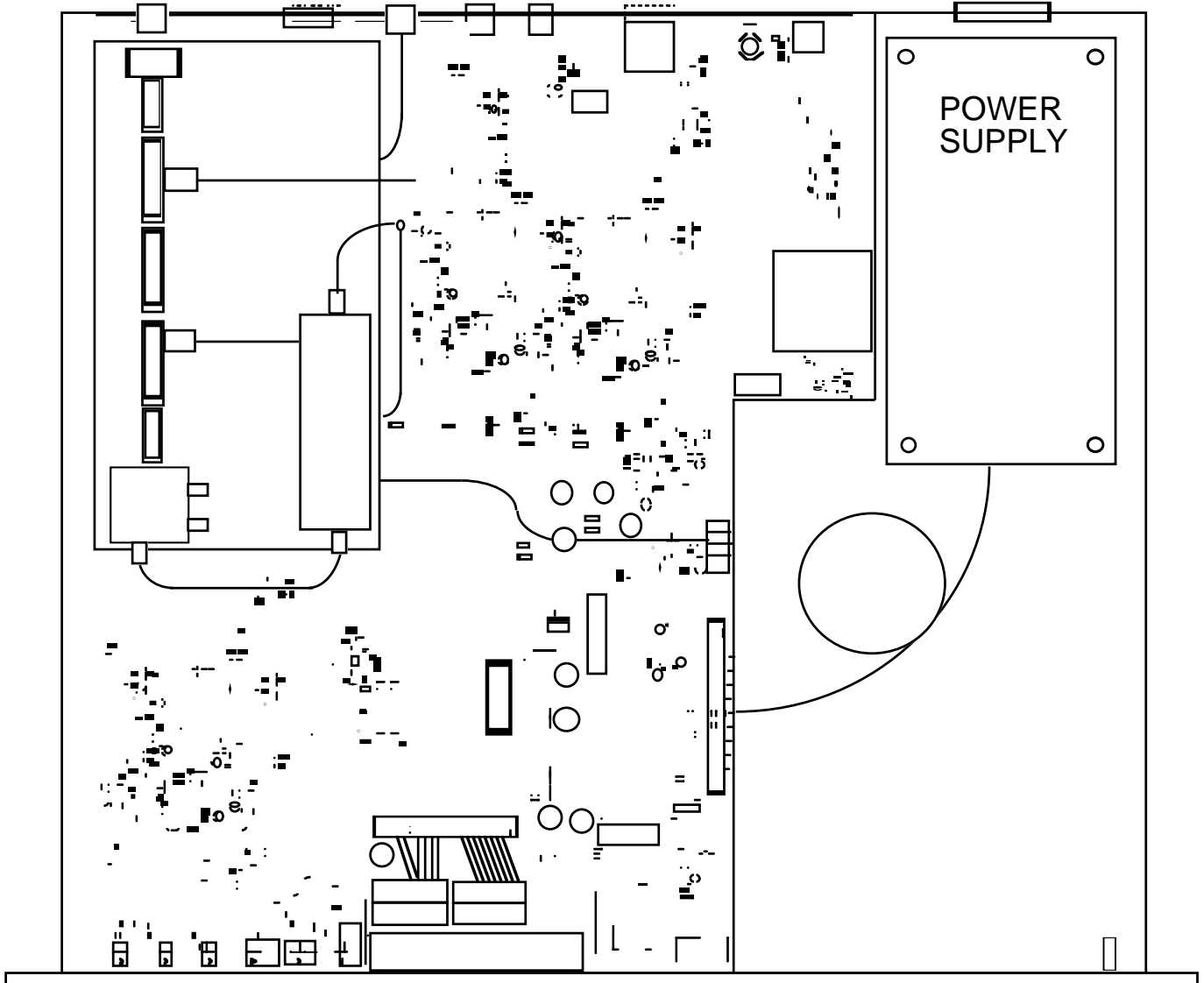

FIGURE 2.0 3115-145-1600 Mechanical Assembly

2.2 Rear Panel Input/Output Signals

Figure 2.1 shows the input and output connectors on the rear panel.

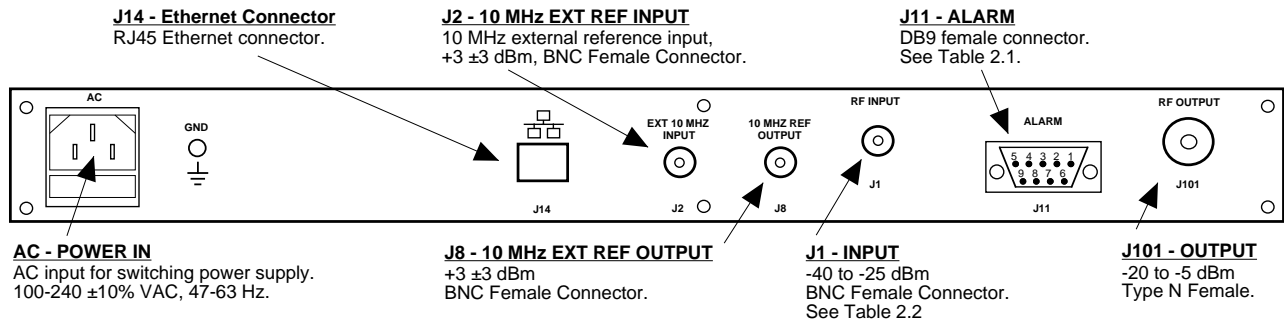

FIGURE 2.1 3115-145-1600 Rear Panel I/O's

TABLE 2.1 J10 Pinouts*	
Pin	Function
1	Rx-
2	Rx+ (RS-232C)
3	Tx+ (RS-232C)
4	Tx-
5	GND
6	Alarm Relay: Common
7	Alarm Relay: Normally Open
8	Not Used
9	Alarm Relay: Normally Closed

TABLE 2.2 Connector Options		
Option	RF	L-Band
-N	50Ω Type N	75Ω BNC
-NN	50Ω Type N	50Ω Type N
-S7	50Ω SMA	75Ω BNC
-SF	50Ω SMA	75Ω Type F
-SN	50Ω SMA	50Ω Type N
-SS	50Ω SMA	50Ω SMA

*Remote Serial Interface

Interface: DB-9 Male Protocol: RS-232C (RS-232C/422/485, **Option Q**),
9600 baud rate, no parity, 8 data bits, 1 start bit, 1 stop bit.

2.3 Front Panel Controls and Indicators

Figure 2.2 shows the front panel controls and indicators.

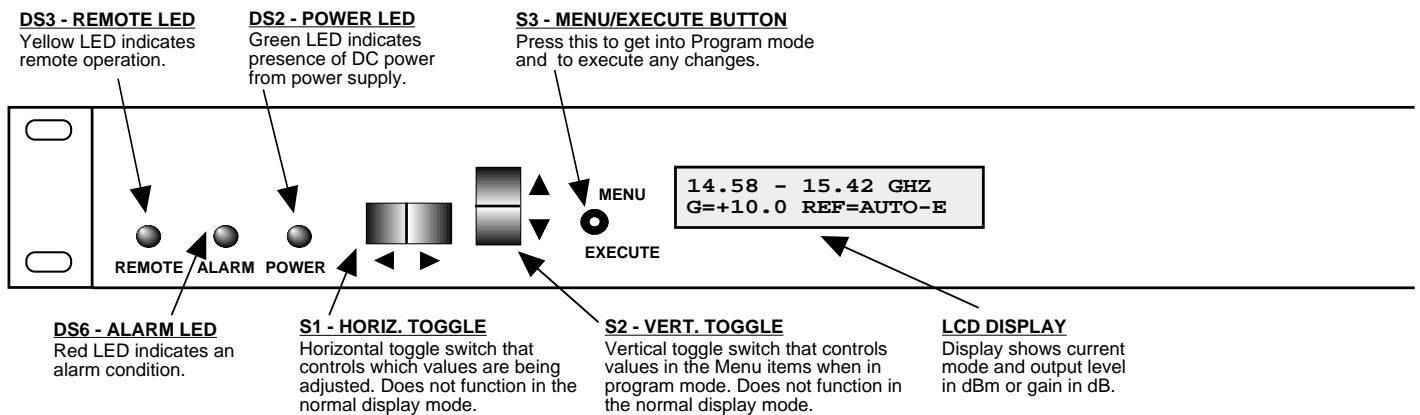

FIGURE 2.2 3115-145-1600 Front Panel Controls and Indicators

2.4 Installation / Operation

2.4.1 Installing and Operating the 3115-145-1600

1. Connect a -40 dBm to -25 dBm signal to L-Band IN, J1 (Figure 2.1).
2. Connect the RF OUT, J101, to the external equipment.
3. Connect 100-240 \pm 10% VAC, 47 - 63 Hz to AC connector on the back panel.
4. Set the gain +35 dB maximum, adjustable in 0.5 \pm 0.5 dB steps
Make sure the output stays within -20 to -5 dBm with the gain selected and the input level provided. (See Section 2.5 Menu Settings).
5. Be sure DS2 (green, DC Power) is on and DS6 (red, Alarm) is off (Figure 2.2).
6. AC Fuse - The fuse is a 5 mm X 20 mm, 2 amp slow blow (Type T) and is inserted in the far slot in the drawer below the AC input as shown in Figure 2.3. There is a spare fuse in the near slot. If a fuse continues to open, the power supply is most likely defective.

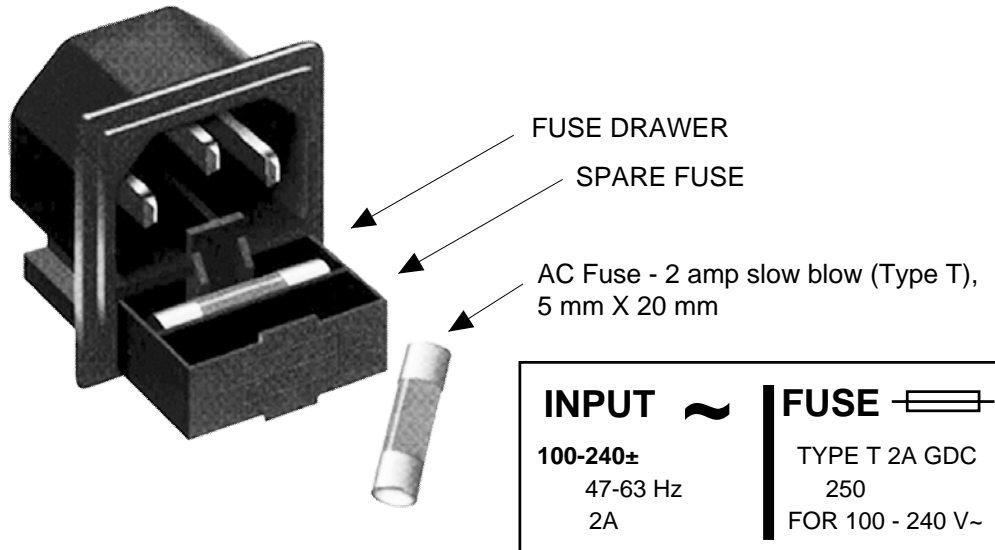

FIGURE 2.3 Fuse Location and Spare Fuse

2.5 Menu Settings

2.5.1 Functions

This section describes operation of the front panel controls. There are three operator switches, the LCD display and alarm indicator LEDs. All functions for the equipment are controlled by these components. The functions are (See Figure 2.4):

Power Up

Normal Display

Menu 1	Set Gain
Menu 2	Set Mute
Menu 3	Set Reference Mode
Menu 4	Set Reference Offset
Menu 5	Set Remote
Menu 6	Set Remote Interface
Menu 7	Set RS-485 Address

Save Menu When “R” is selected from any above menu or at the end.

Alarm indications appear on the LEDs (see Figure 2.2).

All program changes must start with the operation of the Menu/Execute switch and must also end with the operation of the Menu/Execute switch verified by the “Save Settings?” Menu. If this sequence is not followed, none of the changes will take effect. If programming is initiated and no operator action takes place for approximately 30 seconds (before the final press of the Menu/Execute switch) the display will revert to its previous status and you will need to start over.

2.5.2. Power On Settings

NOTE: THE LAST OPERATING PARAMETERS OF A UNIT ARE RETAINED EVEN WHEN POWER IS REMOVED. WHEN POWER IS RESTORED, THE UNIT WILL RETURN TO IT'S PREVIOUS SETTINGS.

When power is first applied, the LCD display goes through three steps.

1. The LCD goes black to show all segments are functioning.
2. The Model and Software version will be displayed.

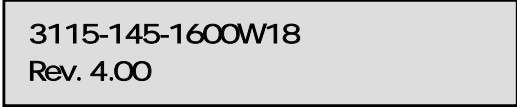

3115-145-1600W18
Rev. 4.00

3. The present frequency and gain of the upconverter is shown.

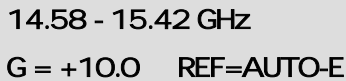

14.58 - 15.42 GHz
G = +10.0 REF=AUTO-E

The unit is now operational and ready for any changes the operator may desire.

2.5.3 Control Switches

1. Menu/Execute - Any change to the programming of the unit must be initiated by pressing the Menu/Execute switch and completed by pressing the Menu/Execute switch.
2. Horizontal Switch - This switch is mounted so its movement is horizontal and moves the display cursor left or right.
3. Vertical Switch - This switch is mounted so its movement is vertical and has two functions:
 - a. During gain changes, the vertical movement will raise or lower the number in the direction of the arrows.
 - b. For other functions such Remote on/off, the vertical switch will alternately turn the function on or off regardless of the direction operated.

2.5.4 Gain Changes

When you get to this menu note that gain changes will be made as you make them but if you do not wish to save the changes you have made, scroll to “**R**” and push the menu/Execute switch and select “**NO**” in the “**SAVE SETTINGS?**” window or **do not press the Menu/Execute switch**; simply do nothing for approximately 30 seconds, and the system will return to the normal operating mode.

NOTE: THE GAIN WILL CHANGE AS YOU ADJUST THE NUMBERS. HOWEVER, THE VALUE WILL NOT BE STORED UNTIL YOU INDICATE YES IN THE SAVE SETTINGS WINDOW. DO NOT SET A GAIN THAT WOULD EXCEED 0 dBm OR HAVE LESS THAN -20 dBm OUTPUT LEVEL.

Press the Up/Down switch to change the gain in 0.5, 1, or 10 dB steps and then push the Menu/Execute switch to get to the Save Settings Menu:

GAIN = +1 <u>7</u>.5 R

When the display indicates the value desired you can push the Menu/Execute switch to the next item OR you can scroll to “**R**”, push the Menu/Execute switch to get to:

SAVE SETTINGS? <u>Y</u>N
--

Selecting **Y** will save the new settings. Selecting **N** will revert to the previous settings.

Figure 2.4 (page 15) gives the menu items and how to make changes.

2.5.5 Alarm Indications

An alarm condition will occur if any local oscillator phase lock loop (PLL) comes out of lock. The Remote LED will light when you select the Remote mode.

2.5.6 10 MHz Reference Mode Operation

Internal Mode: The unit uses its own built-in 10 MHz OCXO. The Internal Reference is present on the Reference Output Connector, J8. REF = INT appears on the front panel display.

External Mode: The unit uses a 10 MHz Reference that is connected to the External Reference Input, J2. REF = EXT appears on the front panel display. The External 10 MHz Reference level must be +3dBm, ± 3 dB. If the External 10 MHz signal does not meet the unit's specified parameters then the unit will not function properly. The External Reference is present on the Reference Output connector, J8.

Auto Mode: The unit defaults to the External 10 MHz Reference as long as the level meets the +3dBm, ± 3 dB specification. REF = AUTO - E appears on the front panel display where the -E indicates that the unit is using the External 10 MHz Reference. The External Reference is present on the Reference Output connector, J8.

If the external 10 MHz Reference signal level is less than -1dBm, the unit switches to Internal 10 MHz Reference. REF = AUTO -I appears on the front panel display where -I indicates that the unit is using the Internal 10 MHz Reference. The Internal 10 MHz Reference is present on the reference output connector, J8.

	ON POWER UP (1)		
Power Up 1:	=== IP Addr === 192.168.123.002		
	ON POWER UP (2)		
Power Up 2:	3115-145-1600W18 4.0		
<hr/>			
	NORMAL DISPLAY		
Normal Display	14.58 - 15.42 GHZ G = +10.0 REF=AUTO-E		PUSH BUTTON
<hr/>			
	PUSHING MENU/EXECUTE SEQUENCE		
Menu 1 Set Gain	GAIN = 15.5 R	SCROLL <> SCROLL ⤴	PUSH BUTTON
Menu 2 Set Mute	MUTE = ON R	SCROLL <> SCROLL ⤴	PUSH BUTTON
Menu 3 Set Reference Mode	REF MODE = AUTO R	SCROLL <> SCROLL ⤴	PUSH BUTTON
Menu 4 Set Reference Offset	INTERNAL FREQ ADJUST OFFSET = -1225 R	SCROLL <> SCROLL ⤴	PUSH BUTTON
Menu 5 Set Remote	REMOTE = ON R	SCROLL <> SCROLL ⤴	PUSH BUTTON
Menu 6 Set Remote Interface	INTERFACE = RS232 R	SCROLL <> SCROLL ⤴	PUSH BUTTON
Menu 7 Set RS485 Address	RS485 ADDRESS = 0 R	SCROLL <> SCROLL ⤴	PUSH BUTTON
Save? When go to end	SAVE SETTINGS? Y N	SCROLL <> SCROLL ⤴	PUSH BUTTON

FIGURE 2.4 Menu Display and Sequences

3.0 Environmental Use Information

- A. Rack-Mounting** - To mount this equipment in a rack, please refer to the installation instructions located in the user manual furnished by the manufacturer of your equipment rack.
- B. Mechanical Loading** - Mounting of equipment in a rack should be such that a hazardous condition does not exist due to uneven weight distribution.
- C. Elevated Operating Ambient Temperature** - If installed in a closed or multi-unit rack assembly, the operating ambient temperature of the rack may be greater than room ambient temperature. Therefore, consideration should be given to Tmra (Maximum Recommended Ambient Temperature).
- D. Reduced Air Flow** - Installation of the equipment in a rack should be such that the amount of air flow required for safe operation of the equipment is not compromised. Additional space between units may be required.
- E. Circuit Overloading** - Consideration should be given to the connection of the equipment to the supply circuit and the effect that overloading of circuits could have on over current protection and supply wiring. Appropriate consideration of equipment name plate rating should be used when addressing this concern.
- F. Reliable Earthing** - Reliable earthing of rack-mounted equipment should be maintained. Particular attention should be given to supply connections other than direct connection to the Branch (use of power strips).
- G. Top Cover** - There are no serviceable parts inside the product so, the Top Cover should not be removed. If the Top Cover is removed the ground strap and associated screw **MUST BE REINSTALLED** prior to Top Cover screw replacement. **FAILURE TO DO** this may cause **INGRESS** and/or **EGRESS** emission problems.

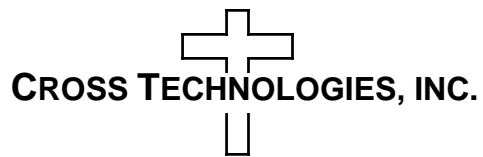

6170 Shiloh Road
Alpharetta, Georgia 30005

(770) 886-8005
FAX (770) 886-7964
Toll Free 888-900-5588

WEB www.crosstechnologies.com
E-MAIL info@crosstechnologies.com

Printed in USA