

Instruction Manual

Model 2117-9395 Up/Downconverter

September 2019, Rev. 0



Data, drawings, and other material contained herein are proprietary to Cross Technologies, Inc., but may be reproduced or duplicated without the prior permission of Cross Technologies, Inc. for purposes of operating the equipment.

When ordering parts from Cross Technologies, Inc., be sure to include the equipment model number, equipment serial number, and a description of the part.



6170 Shiloh Road
Alpharetta, Georgia 30005

(770) 886-8005
FAX (770) 886-7964
Toll Free 888-900-5588

WEB www.crosstechnologies.com
E-MAIL info@crosstechnologies.com

INSTRUCTION MANUAL

MODEL 2117-9395 Up/Downconverter

TABLE OF CONTENTS	PAGE
Warranty	2
1.0 General	3
1.1 Equipment Description	3
1.2 Technical Characteristics	4
2.0 Installation	5
2.1 Mechanical	5
2.2 Front & Rear Inputs and Outputs	6
2.3 Available Options/Pinouts	7
2.4 Installation/Operation	8
2.5 Use Information	9

WARRANTY - The following warranty applies to all Cross Technologies, Inc. products.

All Cross Technologies, Inc. products are warranted against defective materials and workmanship for a period of one year after shipment to customer. Cross Technologies, Inc.'s obligation under this warranty is limited to repairing or, at Cross Technologies, Inc.'s option, replacing parts, subassemblies, or entire assemblies. Cross Technologies, Inc. shall not be liable for any special, indirect, or consequential damages. This warranty does not cover parts or equipment which have been subject to misuse, negligence, or accident by the customer during use. All shipping costs for warranty repairs will be prepaid by the customer. There are not other warranties, express or implied, except as stated herein.



6170 Shiloh Road
Alpharetta, Georgia 30005

(770) 886-8005
FAX (770) 886-7964
Toll Free 888-900-5588

WEB www.crosstechnologies.com
E-MAIL info@crosstechnologies.com

MODEL 2117-9395 Up/Downconverter

9.30-9.50 GHz Up, 9.30-9.50 GHz Down

1.0 General

The 2117-9395 Up/Downconverter converts 2.00 - 2.20 GHz to 9.30 - 9.50 GHz and 9.30-9.50 GHz to 1.60 - 1.80 GHz, with non-inverting spectrums. Front panel LEDs provide indication of DC Power, External 10 MHz, and PLL Alarm. The gain is +20 dB for the upconverter and -20 dB for the downconverter. Connectors are Type N female for the RF output and input, BNC female for the L-band input and output and external reference input and reference output. A three-way switch controls which 10 MHz reference is being used. In the AUTO position, the internal reference is used unless a +3 dBm \pm 3 dB, 10MHz reference signal is connected to the external reference input. The 2117 is powered by a 100-240 \pm 10% VAC power supply, and in a 1 3/4" X 19" X 19" rack mount chassis.



FRONT PANEL

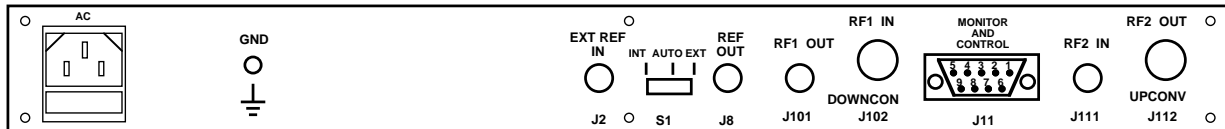

REAR PANEL

FIGURE 1.1 Model 2117-9395 Front and Rear Panels

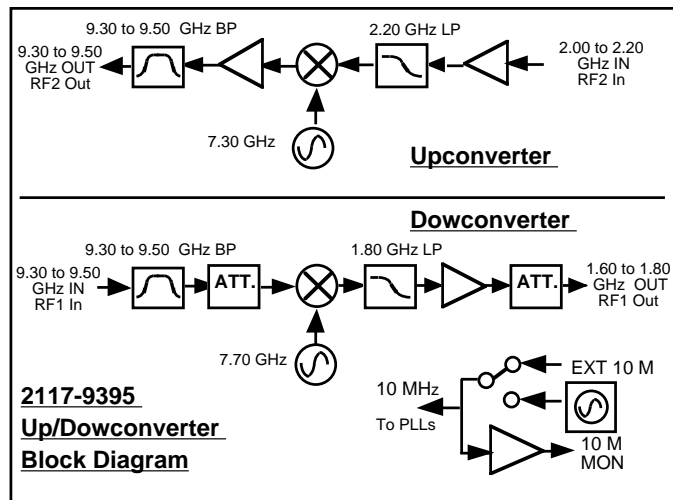

FIGURE 1.2 Model 2117-9395 Up/Downconverter Block Diagram

1.2 Technical Characteristics

TABLE 1.0 2117-9395 Up/Downconverter Specifications*

EQUIPMENTSPECIFICATIONS*		
Input Characteristics	UP, C	DOWN, C
Impedance/Return Loss	50Ω/14 dB	50Ω/14 dB
Frequency	2.00-2.20 GHz	9.30-9.50 GHz
Noise Figure, Max.	20 dB @ max gain	25 dB @ max gain
Input Level range	-40 to -20 dBm	-20 to 0 dBm
Output Characteristics		
Impedance/Return Loss	50 Ω /14 dB	50 Ω /14 dB
Frequency (GHz)	9.30-9.50 GHz	1.60-1.80 GHz
Output Level Range	-20 to 0 dBm	-40 to -20 dBm
1 dB comp, max gain	+10 dBm	-10 dBm
Mute @ 0 dBm out	>50 dB	N/A
Channel Characteristics		
Gain, max. at Fc, fixed	+20 ±2 dB	-20 ±2 dB
Image Rejection	>60 dBC	>60 dBC
Spurious, Inband, sig. rel.	<-50 dBC, 0dBm	<-50 dBC, -5dBm
Spurious, Inband, sig. ind.	<-50 dBC, Gmax	<-50 dBC, Gmax
Spurious, Out of band	<-50 dBm, Gmax	<-50 dBm, Gmax
2 tone 4MHz; Max -10 ea	<-50 dBC,Gmax	<-50 dBC,Gmax
Frequency Resp. band	±1.5 dB	±1.5 dB
Frequency Resp. 85 MHz	± 0.75 dB	± 0.75 dB
Frequency Sense	non-inverting	non-inverting

LO Characteristics

LO Frequency Downconverter -7.70 GHz; Upconverter - 7.30 GHz
 Frequency Accuracy ± 0.01 ppm max over temp internal reference; external reference input
 10 MHz Level +3 dBm, ± 3dB, 75 ohms, External In or Internal out

Phase Noise @ Freq (Hz)	100 MHz	1kHz	10kHz	100kHz	1MHz
dBc/Hz	-70	-80	-85	-100	-110

Controls, Indicators

INT/AUTO/EXT Switch Selects internal or external 10 Mhz 9 (rear panel DP3T switch)
 Ext 10 MHz Yellow LED, indicates external 10 MHz reference selected
 PLL Alarm Red LED, External contact closures
 Power Green LED

Other

RF1 In, RF2 Out N-type (female), 50Ω
 RF1 Out, RF2 In BNC (female), 50Ω
 10 MHz connectors BNC (female), 75Ω connector; works with 50Ω or 75Ω
 Alarm Connector DB9 - NO or NC contact closure on Alarm
 Size 19 inch standard chassis 1.75" high X 14" deep
 Power 100-240 ± 10% VAC, 47 - 63 Hz, 50 watts maximum

Options

Connector Options See TABLE 2.2

*+10°C to +40°C; Specifications subject to change without notice.

2.0 Installation

2.1 Mechanical - The 2117-9395 consists of one RF PCB housed in a 1 RU (1 3/4 inch high) by 14 inch deep chassis. A switching, ± 12 , +24, +5 VDC power supply provides power for the assemblies. The 2117-9395 can be secured to a rack using the 4 holes on the front panel. Figure 2.0 shows how the 2117-9395 is assembled.

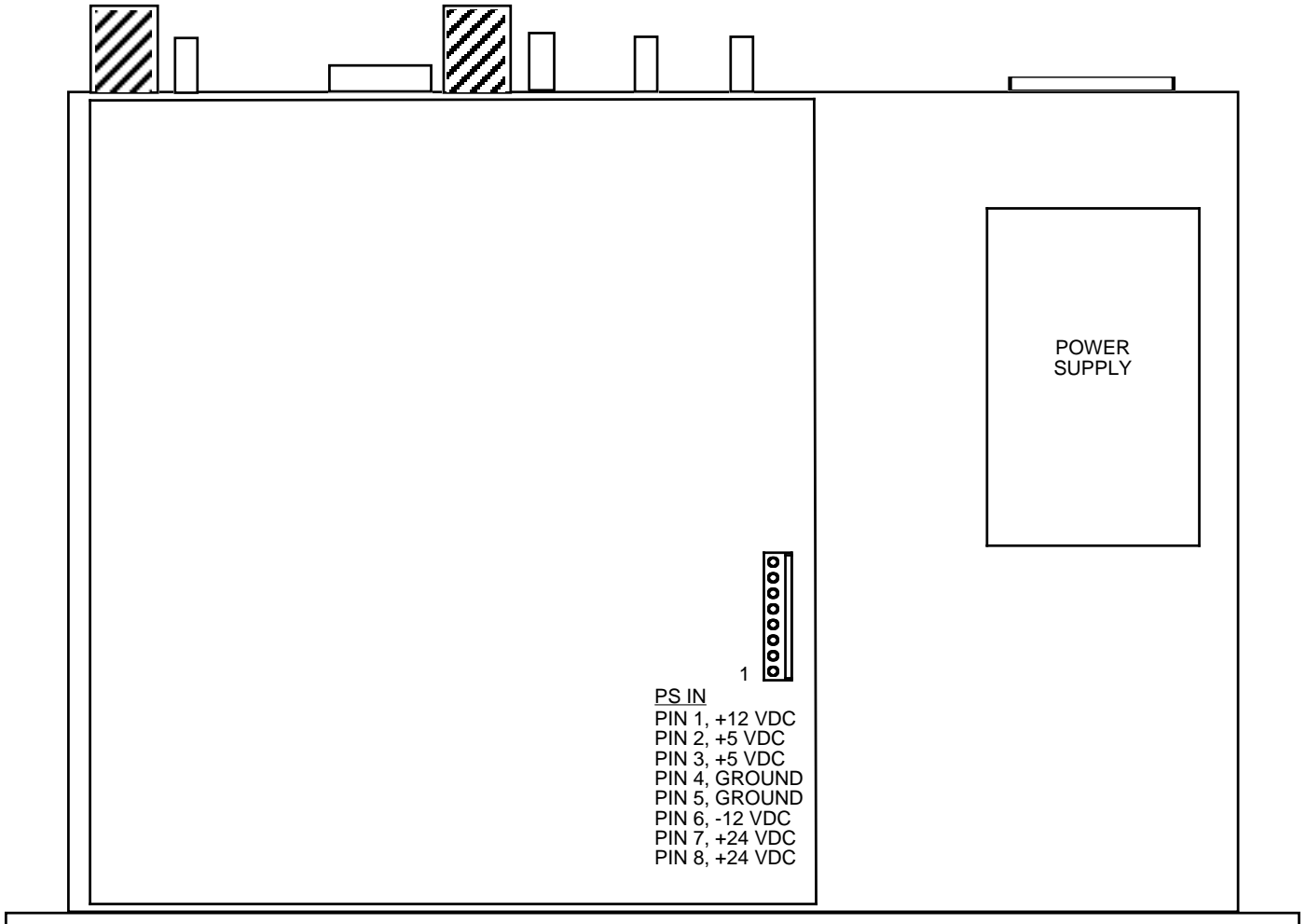
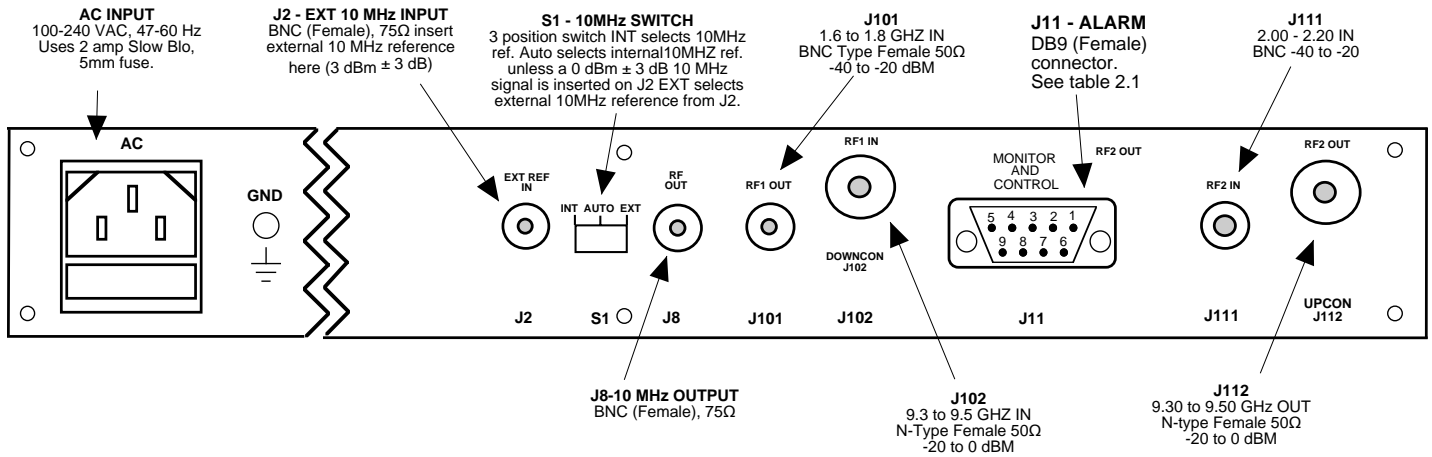

FIGURE 2.0 2117-9395 Mechanical Assembly

2.2 Rear Panel Input/Output Signals - Figure 2.1 shows the input and output connectors on the rear panel.



Shown below (Option P48) - Rear Panel Input/Output Signals with Option P48, 48 VDC nominal 36-72 VDC, 2.5A maximum.

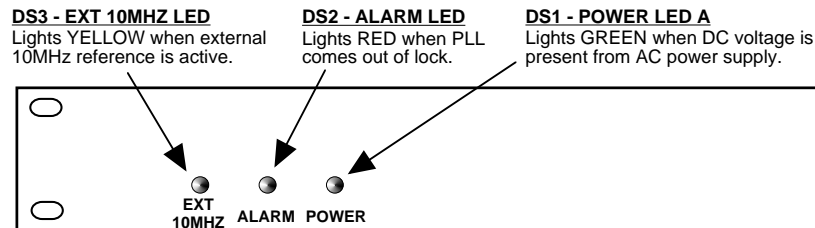
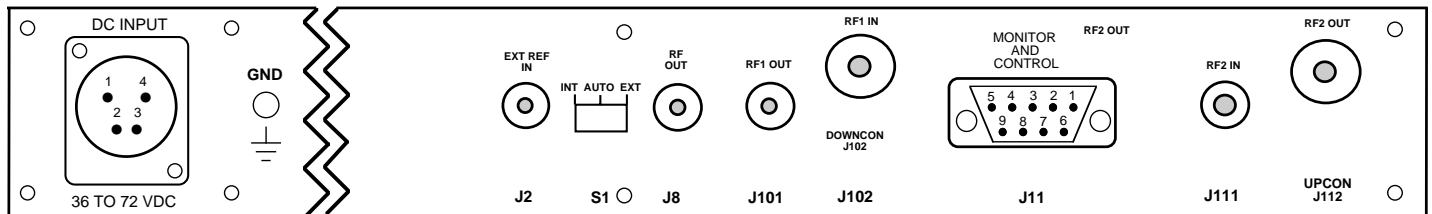

FIGURE 2.2 2117-9395 Front Panel Controls and Indicators

TABLE 2.1 J11 Pinouts (DB9)	
Pin	Function
1	Not Used
2	Not Used
3	Not Used
4	Not Used
5	GND
6	Alarm Relay: Common
7	Alarm Relay: Normally Open
8	Not Used
9	Alarm Relay: Normally Closed

FIGURE 2.1 2117-9395 Rear Panel I/O's

TABLE 2.3 DC1 Pinouts	
Pin#	Function
1	Minus DC input
2	NC
3	Plus DC input
4	NC
Shell	Ground

FIGURE 2.3 2117-9395 DC1 Pinouts

TABLE 2.2	Available Options
P48 =	48 VDC Nominal 36-72 VDC, 2.5A max.
R =	Redundant AC Power Supply
	Available Connector Options
NF	50Ω N-Type (RF), 75Ω F-Type (L-Band)
N	50Ω N-Type (RF), 75Ω BNC (L-Band)
NN	50Ω N-Type (RF), 50Ω N-Type (L-Band)
SS	50Ω SMA (RF), 50Ω SMA (L-Band)

FIGURE 2.2 2117-9395 Available Options

2.4 Installation / Operation

2.4.2 Installing and Operating the 2117-9395 Downconverter

- 1.) Connect a -20 dBm to 0 dBm from 9.30 - 9.50 GHz, signal to RF INPUT, J102 (Figure 2.1).
- 2.) Connect the L-BAND OUTPUT, RF1 OUT, J101 to the external equipment.
Output will be 1.60 - 1.80 GHz.
- 3.) Connect 100-240 \pm 10% VAC, 47 - 63 Hz to AC connector on the back panel.
- 4.) Be sure DS1 (green, DC Power) is on and DS2 (red, Alarm) is off (Figure 2.2).
- 5.) Select either INT (for internal 10MHz ref), AUTO (for internal 10MHz ref UNLESS a external 10MHz, 0 dBm signal is connected to J2), or EXT (for external 10MHz, 0 dBm ref that is inserted at J2) on rear panel switch S1 (Figure 2.1).
- 6.) If EXT is selected or AUTO is selected and there is a 10MHz, 0 dBm signal at J2, check that DS3 (yellow, Ext 10 MHz) is on (Figure 2.2).
- 7.) Check that a 10MHz, 0 dBm \pm 3 dB signal is present at the 10 MHz REF OUTPUT (J8) (Figure 2.1).
- 8.) **AC Fuse** - The fuse is a 5 mm X 20 mm, 2 amp slow blow (Type T) and is inserted in the far slot in the drawer below the AC input as shown in Figure 2.3. There is a spare fuse in the near slot. If a fuse continues to open, the power supply is most likely defective.

2.4.3 Installing and Operating the 2117-9395 Upconverter

1. Connect a -40 dBm to -20 dBm signal, from 2.0 to 2.2 GHz, to L-BAND INPUT, RF2 IN, J111 (Figure 2.1).
2. Connect the RF OUTPUT, J112, to the external equipment.
Output will be 9.3 to 9.5 GHz.
3. Connect 100-240 \pm 10% VAC, 47 - 63 Hz to AC connector on the back panel.
4. Be sure DS1 (green, DC Power) is on and DS2 (red, Alarm) is off (Figure 2.2).
5. Select either INT (for internal 10MHz ref), AUTO (for internal 10MHz ref UNLESS a external 10MHz, 3 dBm signal is connected to J2), or EXT (for external 10MHz, 3 dBm ref that is inserted at J2) on rear panel switch S1 (Figure 2.1).
6. If EXT is selected or AUTO is selected and there is a 10MHz, 3 dBm signal at J2, check that DS3 (yellow, Ext 10MHZ) is on (Figure 2.2).
7. Check that a 10MHz, 3 dBm \pm 3 dB signal is present at the 10MHZ REF OUTPUT (J8) (Figure 2.1).
8. **AC Fuse** - The fuse is a 5 mm X 20 mm, 2 amp slow blow (Type T) and is inserted in the far slot in the drawer below the AC input as shown in Figure 2.3. There is a spare fuse in the near slot. If a fuse continues to open, the power supply is most likely defective.

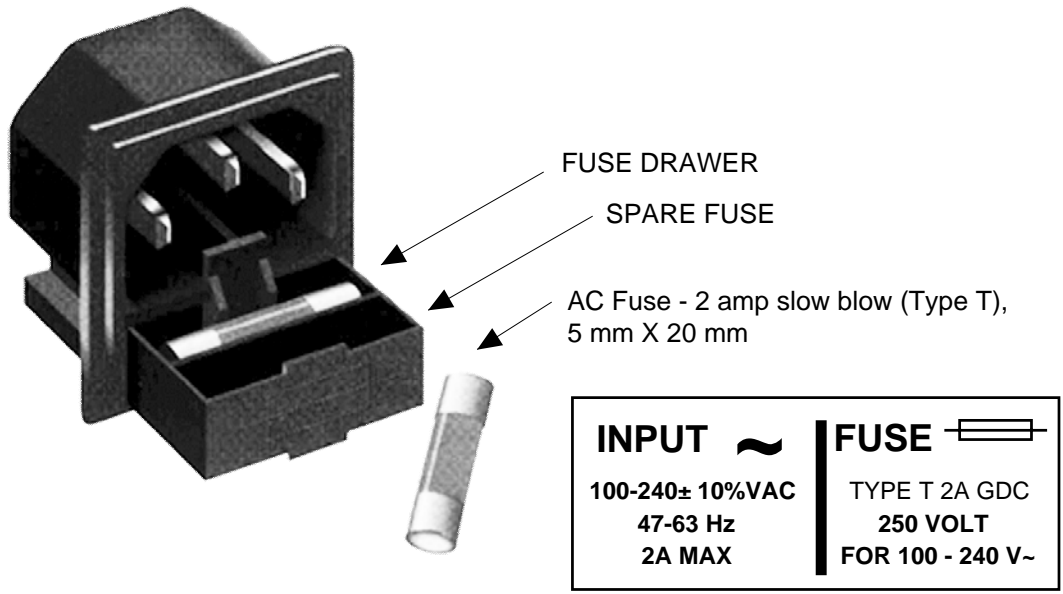

FIGURE 2.3 Fuse Location and Spare Fuse

Use Information

- A. Rack-Mounting** - To mount this equipment in a rack, please refer to the installation instructions located in the user manual furnished by the manufacturer of your equipment rack.
- B. Mechanical Loading** - Mounting of equipment in a rack should be such that a hazardous condition does not exist due to uneven weight distribution.
- C. Elevated Operating Ambient Temperature** - If installed in a closed or multi-unit rack assembly, the operating ambient temperature of the rack may be greater than room ambient temperature. Therefore, consideration should be given to Tmra. (Maximum Recommended Ambient Temperature)
- D. Reduced Air Flow** - Installation of the equipment in a rack should be such that the amount of air flow required for safe operation of the equipment is not compromised. Additional space between units may be required.
- E. Circuit Overloading** - Consideration should be given to the connection of the equipment to the supply circuit and the effect that overloading of circuits could have on over current protection and supply wiring. Appropriate consideration of equipment name plate rating should be used when addressing this concern.
- F. Reliable Earthing** - Reliable earthing of rack-mounted equipment should be maintained. Particular attention should be given to supply connections other than direct connection to the Branch (use of power strips).
- G. Top Cover** - There are no serviceable parts inside the product so, the Top Cover should not be removed. If the Top Cover is removed the ground strap and associated screw **MUST BE REINSTALLED** prior to Top Cover screw replacement. **FAILURE TO DO** this may cause **INGRESS** and/or **EGRESS** emission problems.



6170 Shiloh Road
Alpharetta, Georgia 30005

(770) 886-8005
FAX (770) 886-7964
Toll Free 888-900-5588

WEB www.crosstechnologies.com
E-MAIL info@crosstechnologies.com