

Instruction Manual

Model 2117-3764 Up/Downconverter

September 2019, Rev. B



Data, drawings, and other material contained herein are proprietary to Cross Technologies, Inc., but may be reproduced or duplicated without the prior permission of Cross Technologies, Inc. for purposes of operating the equipment.

When ordering parts from Cross Technologies, Inc., be sure to include the equipment model number, equipment serial number, and a description of the part.



6170 Shiloh Road
Alpharetta, Georgia 30005

(770) 886-8005
FAX (770) 886-7964
Toll Free 888-900-5588

WEB www.crosstechnologies.com
E-MAIL info@crosstechnologies.com

INSTRUCTION MANUAL

MODEL 2117-3764 Up/Downconverter

| TABLE OF CONTENTS | PAGE |
|-------------------------------------|----------|
| Warranty | 2 |
| 1.0 General | 3 |
| 1.1 Equipment Description | 3 |
| 1.2 Technical Characteristics | 4 |
| 2.0 Installation | 5 |
| 2.1 Mechanical | 5 |
| 2.2 Front & Rear Inputs and Outputs | 6 |
| 2.3 Available Options/Pinouts | 7 |
| 2.4 Installation/Operation | 8 |
| 2.5 Use Information | 9 |

WARRANTY - The following warranty applies to all Cross Technologies, Inc. products.

All Cross Technologies, Inc. products are warranted against defective materials and workmanship for a period of one year after shipment to customer. Cross Technologies, Inc.'s obligation under this warranty is limited to repairing or, at Cross Technologies, Inc.'s option, replacing parts, subassemblies, or entire assemblies. Cross Technologies, Inc. shall not be liable for any special, indirect, or consequential damages. This warranty does not cover parts or equipment which have been subject to misuse, negligence, or accident by the customer during use. All shipping costs for warranty repairs will be prepaid by the customer. There are not other warranties, express or implied, except as stated herein.



6170 Shiloh Road
Alpharetta, Georgia 30005

(770) 886-8005
FAX (770) 886-7964
Toll Free 888-900-5588

WEB www.crosstechnologies.com
E-MAIL info@crosstechnologies.com

MODEL 2117-3764 Up/Downconverter

1.0 General

The 2117-3764 Up/Downconverter converts 0.95 - 1.45 GHz to 5.925 - 6.425 GHz and 3.70-4.20 GHz to 0.95 - 1.45 GHz, with inverting spectrums. Front panel LEDs provide indication of DC Power, External 10 MHz, and PLL Alarm. The gain is +20 dB for the upconverter and +35 dB for the downconverter. Connectors are Type N female for the RF output and input, BNC female for the L-band input and output and external reference input and reference output. A three-way switch controls which 10 MHz reference is being used. In the AUTO position, the internal reference is used unless a +3 dBm \pm 3 dB, 10MHz reference signal is connected to the external reference input. The 2117 is powered by a 100-240 \pm 10% VAC power supply, and in a 1 3/4" X 19" X 19" rack mount chassis.

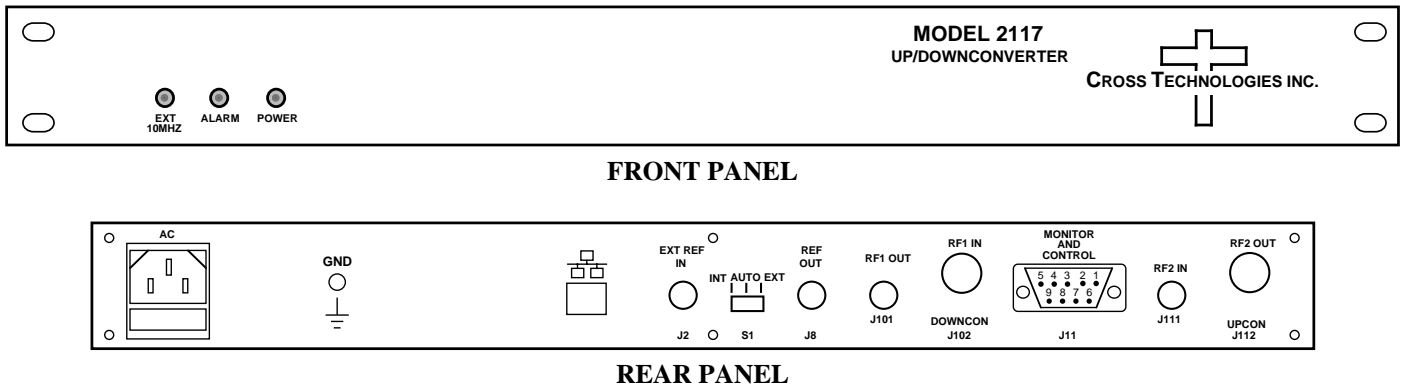

FIGURE 1.1 Model 2117-3764 Front and Rear Panels

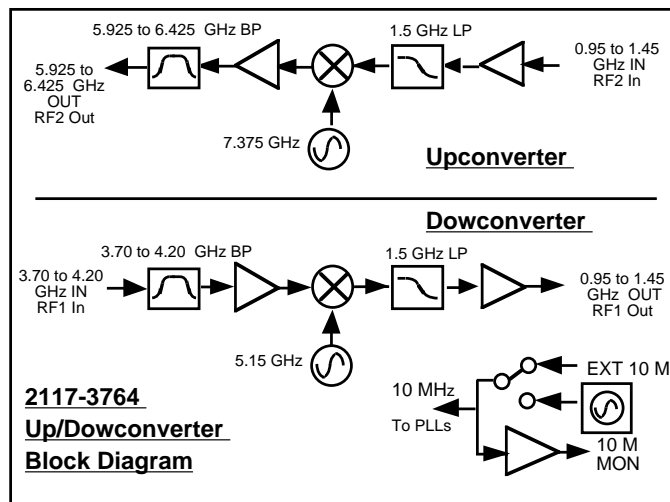

FIGURE 1.2 Model 2117-3764 Up/Downconverter Block Diagram

1.2 Technical Characteristics

TABLE 1.0 2117-3764 Up/Downconverter Specifications*

| EQUIPMENT SPECIFICATIONS* | | |
|--------------------------------|------------------|------------------|
| Input Characteristics | UP, C | DOWN, C |
| Impedance/Return Loss | 50Ω/14 dB | 50Ω/14 dB |
| Frequency | 0.95-1.45 GHz | 3.70-4.20 GHz |
| Noise Figure, Max. | 20 dB @ max gain | 12 dB @ max gain |
| Input Level range | -40 to -20 dBm | -55 to -35 dBm |
| Output Characteristics | | |
| Impedance/Return Loss | 50 Ω /14 dB | 50 Ω /14 dB |
| Frequency (GHz) | 5.925-6.425 GHz | 0.95-1.45 GHz |
| Output Level Range | -20 to 0 dBm | -20 to 0 dBm |
| 1 dB comp, max gain | +10 dBm | +10 dBm |
| Mute @ 0 dBm out | >50 dB | N/A |
| Channel Characteristics | | |
| Gain, max. at Fc | +20 ±1 dB | +35 ±2 dB |
| Gain, range, 0.5±0.5 dB step | FIXED GAIN | FIXED GAIN |
| Image Rejection | >60 dBC | >60 dBC |
| Spurious, Inband, sig. rel. | <-50 dBC,0dBm | <-50 dBC,-5dBm |
| Spurious, Inband, sig. ind. | <-50 dBC,Gmax | <-50 dBC,Gmax |
| Spurious, Out of band | <-50 dBm, Gmax | <-50 dBm, Gmax |
| 2 tone 4MHz del, -10 ea | <-50 dBC,Gmax | <-50 dBC,Gmax |
| Frequency Resp. band | ±2 dB | ±2 dB |
| Frequency Resp. 40 MHz | ± 0.5 dB | ± 0.5 dB |
| Frequency Sense | Inverting | Inverting |

LO Characteristics

LO Frequency Downconverter -5.15 GHz; Upconverter - 7.375 GHz
 Frequency Accuracy ± 0.01 ppm max over temp internal reference; external reference input
 10 MHz Level +3 dBm, ± 3dB, 75 ohms, External In or Internal out

| Phase Noise @ Freq (Hz) | 100 MHz | 1kHz | 10kHz | 100kHz | 1MHz |
|-------------------------|---------|------|-------|--------|------|
| dBC/Hz | -70 | -80 | -85 | -100 | -110 |

Controls, Indicators

INT/AUTO/EXT Switch Selects internal or external 10 Mhz 9 (rear panel DP3T switch)
 Ext 10 MHz Yellow LED, indicates external 10 MHz reference selected
 PLL Alarm Red LED, External contact closures for Band 1 & Band 2
 Power Green LED

Other

RF Connector N-Type, 50Ω, female (see TABLE 2.2 for other options)
 L-Band Connector BNC, 50Ω, female (see TABLE 2.2 for other options)
 10 MHz Connectors BNC, 75Ω, female
 Alarm Connector DB9, female - NO or NC contact closure on Alarm
 Size 19 inch Standard Chassis 1.75"high X 14.0" deep
 Power 100-240 ± 10% VAC, 47-63 Hz, 45 watts maximum

Options

Connector Options See TABLE 2.2

*+10°C to +40°C; Specifications subject to change without notice.

2.0 Installation

2.1 Mechanical - The 2117-3764 consists of one RF PCB housed in a 1 RU (1 3/4 inch high) by 14 inch deep chassis. A switching, ± 12 , +24, +5 VDC power supply provides power for the assemblies. The 2117-3764 can be secured to a rack using the 4 holes on the front panel. Figure 2.0 shows how the 2117-3764 is assembled.

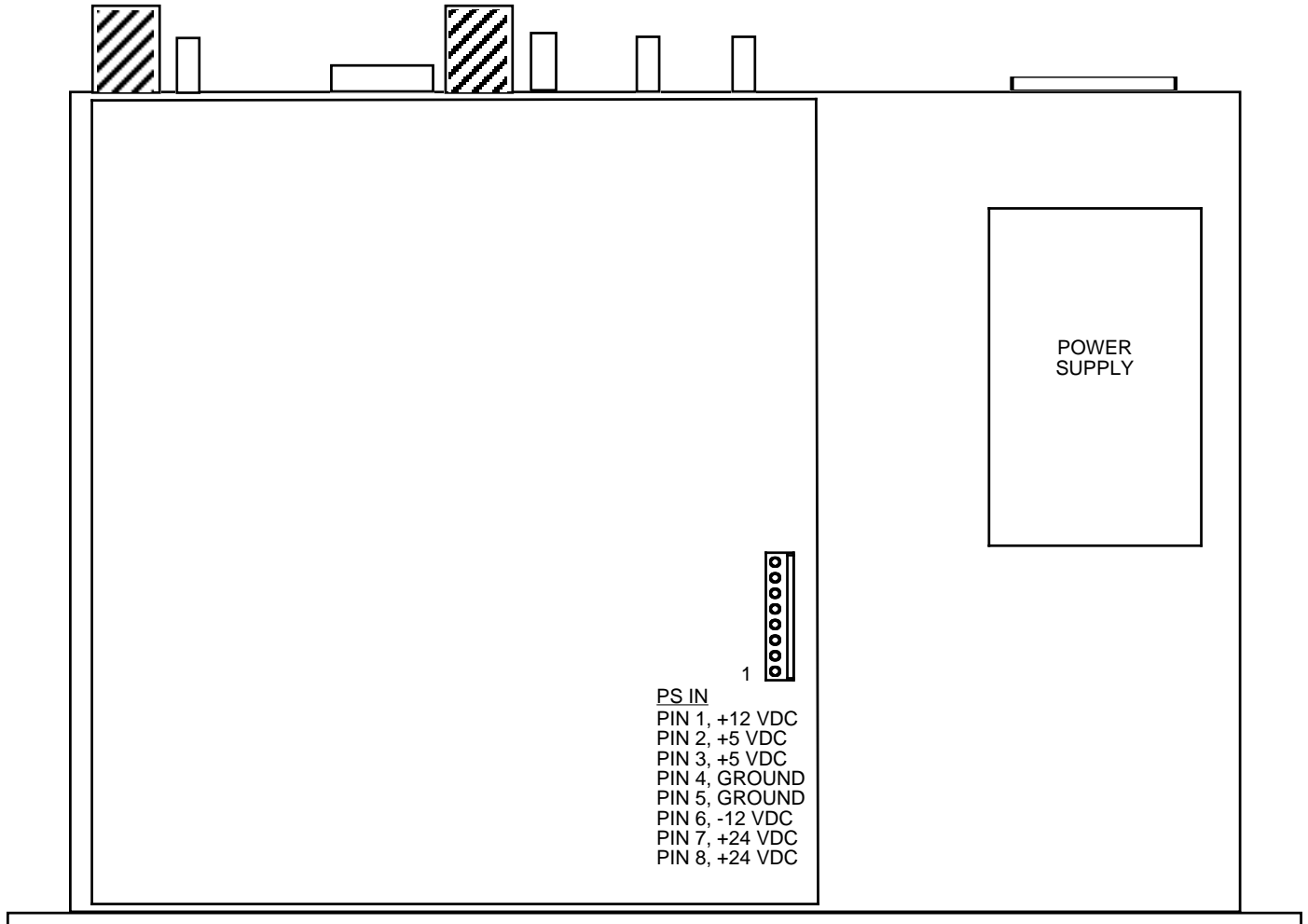
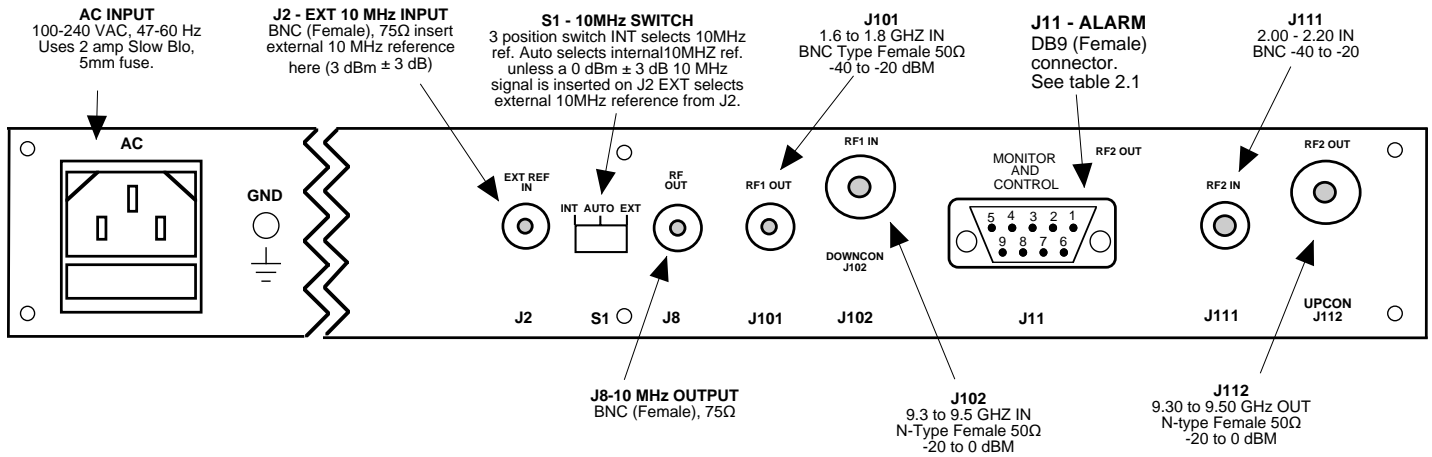

FIGURE 2.0 2117-3764 Mechanical Assembly

2.2 Rear Panel Input/Output Signals - Figure 2.1 shows the input and output connectors on the rear panel.



Shown below (Option P48) - Rear Panel Input/Output Signals
with Option P48, 48 VDC nominal 36-72 VDC, 2.5A maximum.

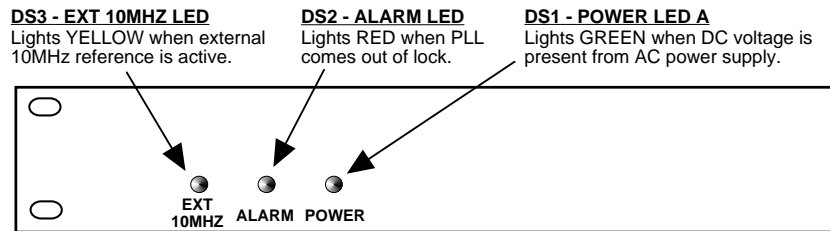
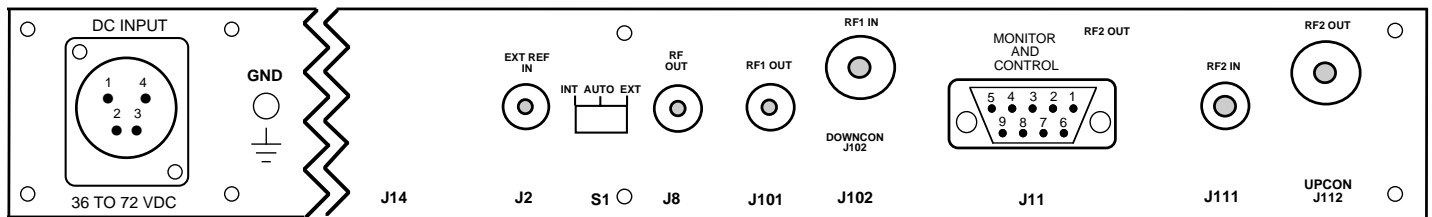

FIGURE 2.2 2117-3764 Front Panel Controls and Indicators

| TABLE 2.1 J11 Pinouts (DB9) | |
|-----------------------------|------------------------------|
| Pin | Function |
| 1 | Not Used |
| 2 | Not Used |
| 3 | Not Used |
| 4 | Not Used |
| 5 | GND |
| 6 | Alarm Relay: Common |
| 7 | Alarm Relay: Normally Open |
| 8 | Not Used |
| 9 | Alarm Relay: Normally Closed |

FIGURE 2.1 2117-3764 Rear Panel I/O's

| TABLE 2.3 DC1 Pinouts | |
|-----------------------|----------------|
| Pin# | Function |
| 1 | Minus DC input |
| 2 | NC |
| 3 | Plus DC input |
| 4 | NC |
| Shell | Ground |

FIGURE 2.3 2117-3764 DC1 Pinouts

| TABLE 2.2 | Available Options |
|-----------|--------------------------------------|
| P48 = | 48 VDC Nominal 36-72 VDC, 2.5A max. |
| R = | Redundant AC Power Supply |
| | Available Connector Options |
| NF | 50Ω N-Type (RF), 75Ω F-Type (L-Band) |
| N | 50Ω N-Type (RF), 75Ω BNC (L-Band) |
| NN | 50Ω N-Type (RF), 50Ω N-Type (L-Band) |
| SS | 50Ω SMA (RF), 50Ω SMA (L-Band) |

FIGURE 2.2 2117-3764 Available Options

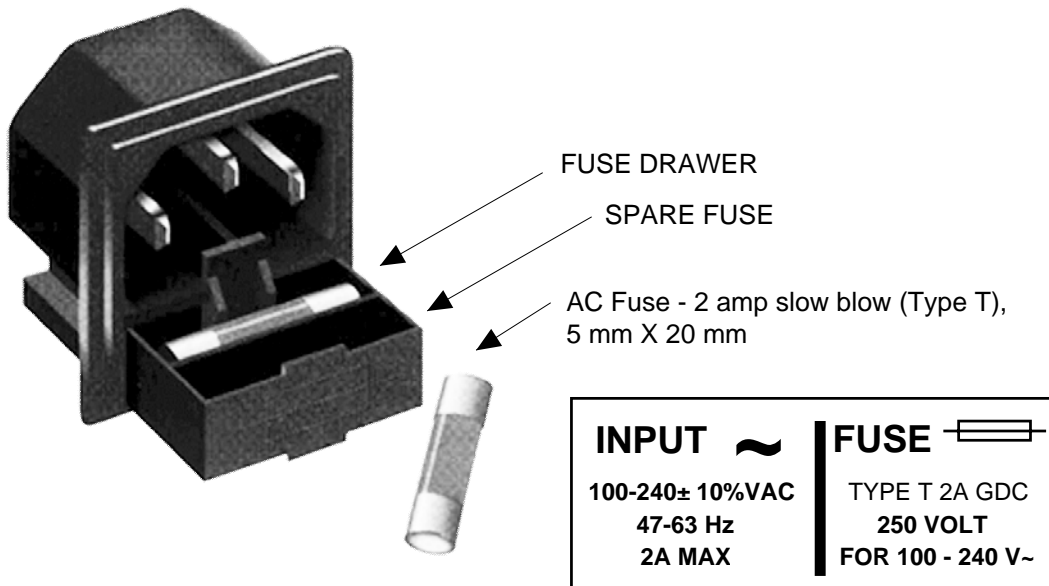

FIGURE 2.3 Fuse Location and Spare Fuse

2.4 Installation / Operation

2.4.2 Installing and Operating the 2117-3764 Downconverter

- 1.) Connect a -55 dBm to -35 dBm signal to RF INPUT, J102 (Figure 2.1).
- 2.) Connect the L-BAND OUTPUT, RF1 OUT, J101 to the external equipment.
- 3.) Connect 100-240 \pm 10% VAC, 47 - 63 Hz to AC connector on the back panel.
- 4.) Be sure DS1 (green, DC Power) is on and DS2 (red, Alarm) is off (Figure 2.2).
- 5.) Select either INT (for internal 10MHz ref), AUTO (for internal 10MHz ref UNLESS a external 10MHz, 0 dBm signal is connected to J2), or EXT (for external 10MHz, 0 dBm ref that is inserted at J2) on rear panel switch S1 (Figure 2.1).
- 6.) If EXT is selected or AUTO is selected and there is a 10MHz, 0 dBm signal at J2, check that DS3 (yellow, Ext 10 MHz) is on (Figure 2.2).
- 7.) Check that a 10MHz, 0 dBm \pm 3 dB signal is present at the 10 MHz REF OUTPUT (J8) (Figure 2.1).
- 8.) **AC Fuse** - The fuse is a 5 mm X 20 mm, 2 amp slow blow (Type T) and is inserted in the far slot in the drawer below the AC input as shown in Figure 2.3. There is a spare fuse in the near slot. If a fuse continues to open, the power supply is most likely defective

2.4.3 Installing and Operating the 2117-3764 Upconverter

1. Connect a -40 dBm to -20 dBm signal to L-BAND INPUT, RF2 IN, J111 (Figure 2.1).
2. Connect the RF OUTPUT, J112, to the external equipment.
3. Connect 100-240 \pm 10% VAC, 47 - 63 Hz to AC connector on the back panel.
4. Be sure DS1 (green, DC Power) is on and DS2 (red, Alarm) is off (Figure 2.2).
5. Select either INT (for internal 10MHz ref), AUTO (for internal 10MHz ref UNLESS a external 10MHz, 3 dBm signal is connected to J2), or EXT (for external 10MHz, 3 dBm ref that is inserted at J2) on rear panel switch S1 (Figure 2.1).
6. If EXT is selected or AUTO is selected and there is a 10MHz, 3 dBm signal at J2, check that DS3 (yellow, Ext 10MHZ) is on (Figure 2.2).
7. Check that a 10MHz, 3 dBm \pm 3 dB signal is present at the 10MHZ REF OUTPUT (J8) (Figure 2.1).
8. **AC Fuse** - The fuse is a 5 mm X 20 mm, 2 amp slow blow (Type T) and is inserted in the far slot in the drawer below the AC input as shown in Figure 2.3. There is a spare fuse in the near slot. If a fuse continues to open, the power supply is most likely defective.

Use Information

- A. Rack-Mounting** - To mount this equipment in a rack, please refer to the installation instructions located in the user manual furnished by the manufacturer of your equipment rack.
- B. Mechanical Loading** - Mounting of equipment in a rack should be such that a hazardous condition does not exist due to uneven weight distribution.
- C. Elevated Operating Ambient Temperature** - If installed in a closed or multi-unit rack assembly, the operating ambient temperature of the rack may be greater than room ambient temperature. Therefore, consideration should be given to Tmra. (Maximum Recommended Ambient Temperature)
- D. Reduced Air Flow** - Installation of the equipment in a rack should be such that the amount of air flow required for safe operation of the equipment is not compromised. Additional space between units may be required.
- E. Circuit Overloading** - Consideration should be given to the connection of the equipment to the supply circuit and the effect that overloading of circuits could have on over current protection and supply wiring. Appropriate consideration of equipment name plate rating should be used when addressing this concern.
- F. Reliable Earthing** - Reliable earthing of rack-mounted equipment should be maintained. Particular attention should be given to supply connections other than direct connection to the Branch (use of power strips).
- G. Top Cover** - There are no serviceable parts inside the product so, the Top Cover should not be removed. If the Top Cover is removed the ground strap and associated screw **MUST BE REINSTALLED** prior to Top Cover screw replacement. **FAILURE TO DO** this may cause **INGRESS** and/or **EGRESS** emission problems.



6170 Shiloh Road
Alpharetta, Georgia 30005

(770) 886-8005
FAX (770) 886-7964
Toll Free 888-900-5588

WEB www.crosstechnologies.com
E-MAIL info@crosstechnologies.com