

# Instruction Manual

# Model 2116-55 Block Downconverter

April 2009 Rev A

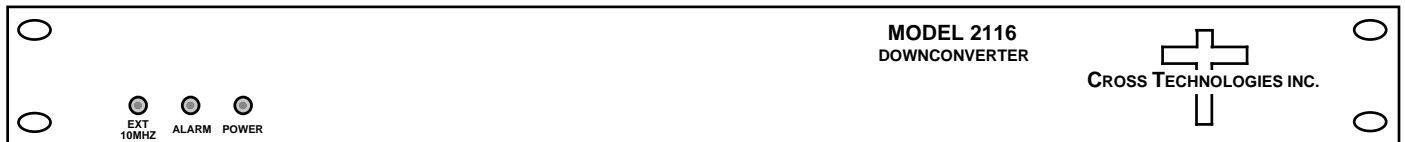

Data, drawings, and other material contained herein are proprietary to Cross Technologies, Inc., but may be reproduced or duplicated without the prior permission of Cross Technologies, Inc. for purposes of operating the equipment.

When ordering parts from Cross Technologies, Inc., be sure to include the equipment model number, equipment serial number, and a description of the part.



6170 Shiloh Road  
Alpharetta, Georgia 30005

(770) 886-8005  
FAX (770) 886-7964  
Toll Free 888-900-5588

WEB [www.crosstechnologies.com](http://www.crosstechnologies.com)  
E-MAIL [info@crosstechnologies.com](mailto:info@crosstechnologies.com)

# INSTRUCTION MANUAL

## MODEL 2116-55 Downconverter

<u>TABLE OF CONTENTS</u>	<u>PAGE</u>
Warranty	2
1.0 General	3
1.1 Equipment Description	3
1.2 Technical Characteristics	4
1.3 Environmental Use Information	5
2.0 Installation	6
2.1 Mechanical	6
2.2 Rear Inputs and Outputs	7
2.3 Front Panel Indicators	7
2.4 Operation	8

**WARRANTY** - The following warranty applies to all Cross Technologies, Inc. products.

All Cross Technologies, Inc. products are warranted against defective materials and workmanship for a period of one year after shipment to customer. Cross Technologies, Inc.'s obligation under this warranty is limited to repairing or, at Cross Technologies, Inc.'s option, replacing parts, subassemblies, or entire assemblies. Cross Technologies, Inc. shall not be liable for any special, indirect, or consequential damages. This warranty does not cover parts or equipment which have been subject to misuse, negligence, or accident by the customer during use. All shipping costs for warranty repairs will be prepaid by the customer. There are not other warranties, express or implied, except as stated herein.



6170 Shiloh Road  
Alpharetta, Georgia 30005

(770) 886-8005  
FAX (770) 886-7964  
Toll Free 888-900-5588

WEB [www.crosstechnologies.com](http://www.crosstechnologies.com)  
E-MAIL [info@crosstechnologies.com](mailto:info@crosstechnologies.com)

# MODEL 2116-55 Downconverter

## 1.0 General

**1.1 Equipment Description** - The 2116-55 Downconverter converts 5.5 - 6.0 GHz to 1.2 - 1.7 GHz with low phase noise and flat frequency response. Frequency translation is via a 7.2 GHz local oscillator. Front panel LEDs provide indication of DC Power, External 10 MHz, and PLL Alarm. The gain is +35 dB. Connectors are Type N female for the RF and BNC female for the L-Band and external reference input and reference output. A three-way switch controls which 10 MHz reference is being used. In the INT position, the internal reference is used, in the EXT position, the external reference is used, and in the AUTO position, the internal reference is used unless a 3 dBm  $\pm$  3 dB, 10MHz reference signal is connected to the external reference input. The 2116 is powered by a 100-240  $\pm$ 10% VAC power supply, and mounted in a 1 3/4" X 19" X 14" rack mount chassis.

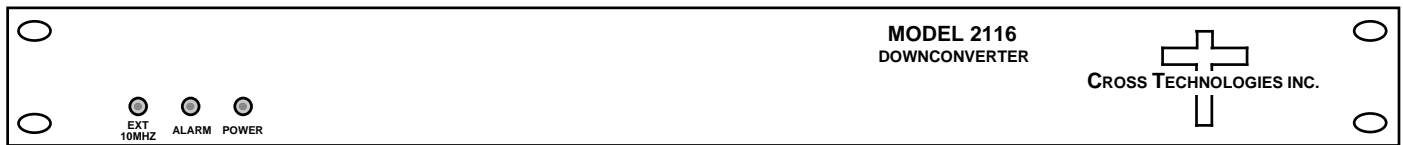

**FRONT PANEL**

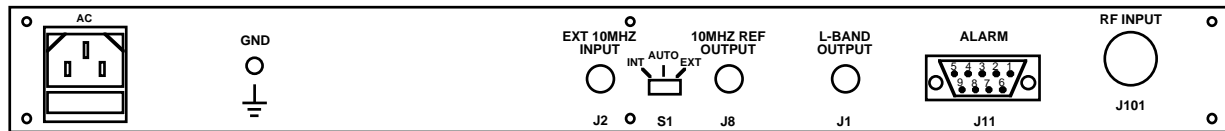

**REAR PANEL**

**FIGURE 1.1 Model 2116-55 Front and Rear Panels**

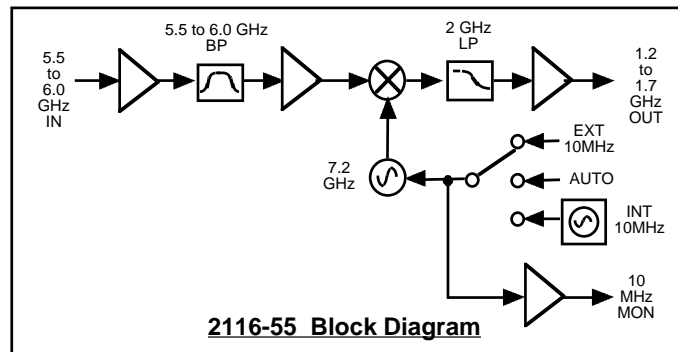

**FIGURE 1.2 Model 2116-55 Downconverter Block Diagram**

## 1.2 Technical Characteristics

**TABLE 1.0 2116-55 Downconverter Specifications\***

### Input Characteristics

Impedance/Return Loss	50 $\Omega$ /14 dB (see TABLE 2.2 for connector options)
Frequency	5.5 to 6.0 GHz
Noise Figure, max.	15 dB, max gain
Input Level	-55 to -35 dBm
Input 1dB Compression	-25 dBm

### Output Characteristics

Impedance/Return Loss	50 $\Omega$ /14 dB (see TABLE 2.2 for connector options)
Frequency	1.2 to 1.7 GHz
Output Level Range	-20 to 0 dBm
Output 1dB Compression	+10 dBm

### Channel Characteristics

Gain	+35 dB $\pm$ 2 dB
Image Rejection	>60 dB, min.
Spurious, Inband	<-60 dBC (0 dBm output level) SIGNAL RELATED
Spurious, Out of Band	<-50 dBC
Intermodulation	<-55 dBC for two carriers each @ -10 dBm out
Frequency Response	$\pm$ 1.5 dB, 1.2 to 1.7 GHz out; $\pm$ 0.5 dB, 40 MHz BW
Frequency Sense	Inverting

### LO Characteristics

LO Frequency	5.15 GHz
Frequency Accuracy	$\pm$ 0.01 ppm max over temp internal reference

Phase Noise @ Freq	100 Hz	1kHz	10kHz	100kHz	1MHz
dBC/Hz	-70	-80	-85	-100	-110

10 MHz Level 0 dBm,  $\pm$  3 dB, 75 ohms, External In or 10MHz Out

### Controls, Indicators

Power	Green LED
PLL Alarm	Red LED, External contact closure
Ext 10 MHz	Yellow LED, Indicates Ext 10 MHz reference is active

### Other

RF Connector	N-type (female), 50 $\Omega$
L-Band Connector	BNC (female), 50 $\Omega$
10 MHz Connectors	BNC (female), 50 $\Omega$ /75 $\Omega$
Alarm Connector	DB9 - NO or NC contact closure on Alarm
Size	19 inch standard chassis 1.7" high X 14.0" deep
Power	100 - 240 $\pm$ 10% VAC, 47 - 63 Hz, 45 watts max.

### Options

Connector options	see TABLE 2.2
-------------------	---------------

\*+10°C to +40°C; Specifications subject to change without notice.

### 1.3 Environmental Use Information

- A. **Rack-Mounting** - To mount this equipment in a rack, please refer to the installation instructions located in the user manual furnished by the manufacturer of your equipment rack.
- B. **Mechanical loading** - Mounting of equipment in a rack should be such that a hazardous condition does not exist due to uneven weight distribution.
- C. **Elevated operating ambient temperature** - If installed in a closed or multi-unit rack assembly, the operating ambient temperature of the rack may be greater than room ambient temperature. Therefore, consideration should be given to Tmra.
- D. **Reduced air flow** - Installation of the equipment in a rack should be such that the amount of air flow required for safe operation of the equipment is not compromised. Additional space between unit may be required.
- E. **Circuit Overloading** - Consideration should be given to the connection of the equipment to the supply circuit and the effect that overloading of circuits could have on over current protection and supply wiring. Appropriate consideration of equipment name plate rating should be used, when addressing this concern.
- F. **Reliable Earthing** - Reliable earthing of rack-mounted equipment should be maintained. Particular attention should be given to supply connections other than direct connection to the Branch (use of power strips).
- G. **Top Cover** - There are no serviceable parts inside the product so, the Top Cover should not be removed. If the Top Cover is removed the ground strap and associated screw **MUST BE REINSTALLED** prior to Top Cover screw replacement. **FAILURE TO DO** this may cause **INGRESS** and/or **EGRESS** emission problems.

## 2.0 Installation

**2.1 Mechanical** - The 2116-55 consists of one RF PCB housed in a 1 RU (1 3/4 inch high) by 12 inch deep chassis. A switching,  $\pm 12$ , +24, +5 VDC power supply provides power for the assemblies. The 2116-55 can be secured to a rack using the 4 holes on the front panel. Figure 2.0 shows how the 2116-55 is assembled.

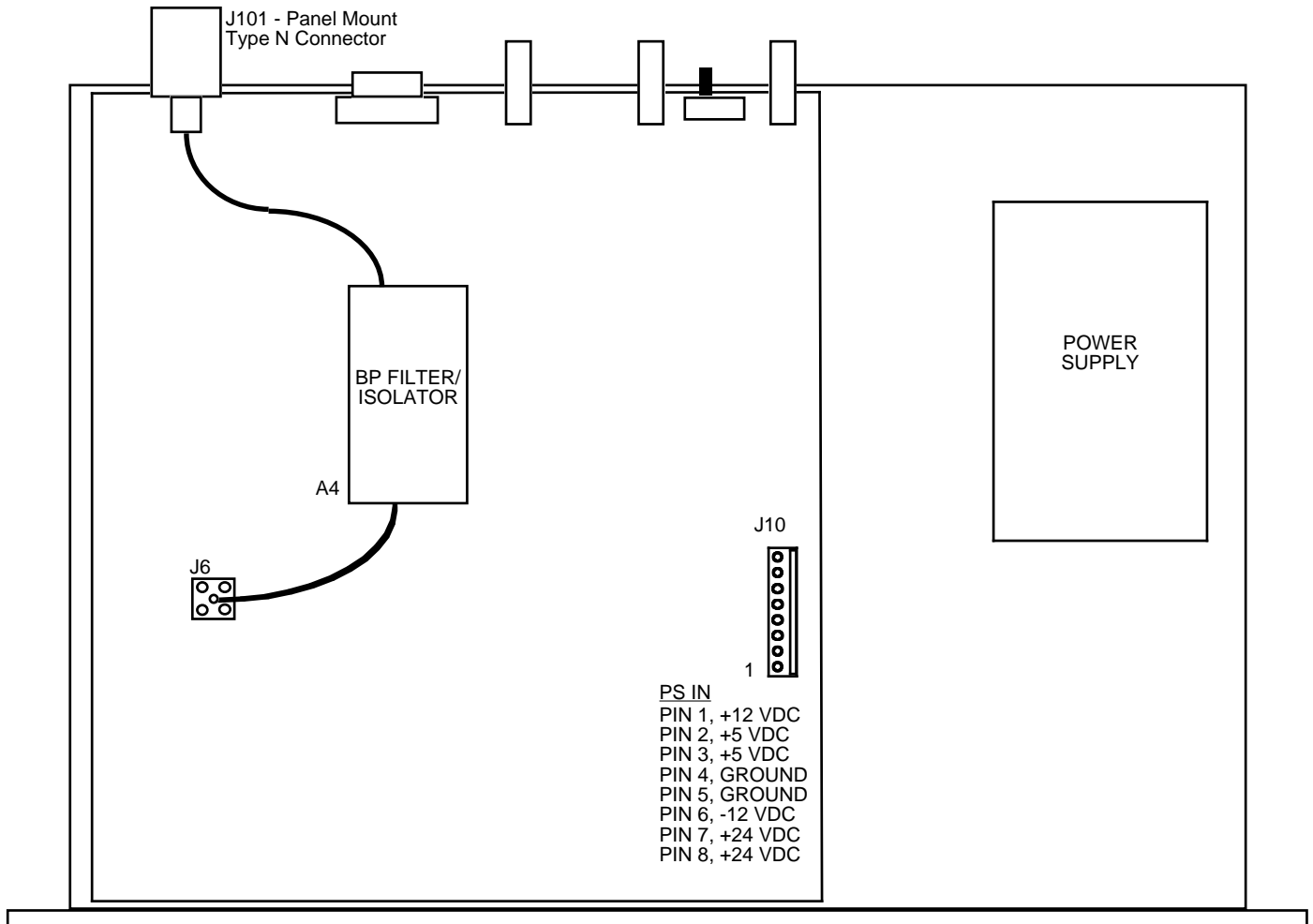

**FIGURE 2.0 2116-55 Mechanical Assembly**

**2.2 Rear Panel Input/Output Signals** - Figure 2.1 shows the input and output connectors on the rear panel.

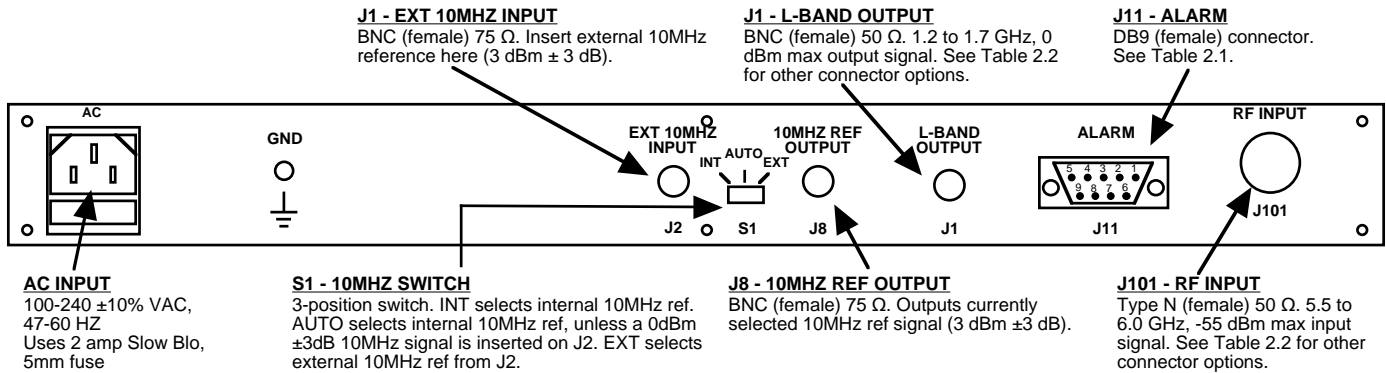
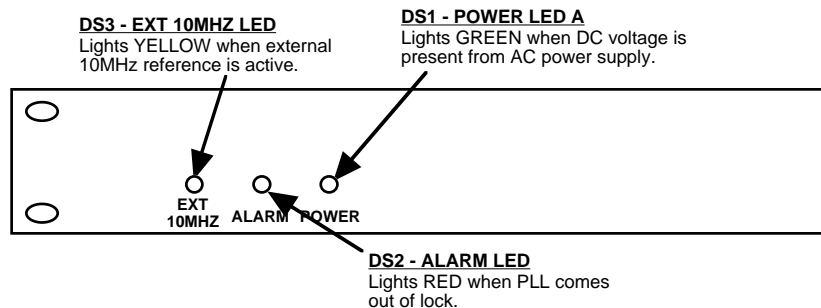

**FIGURE 2.1 2116-55 Rear Panel I/O's**

Pin	Function
1	Not Used
2	Not Used
3	Not Used
4	Not Used
5	GND
6	Alarm Relay: Common
7	Alarm Relay: Normally Open
8	Not Used
9	Alarm Relay: Normally Closed

L-Band	RF
BNC, 50Ω (STD)	Type N, 50Ω (STD)
BNC, 75Ω	SMA, 50Ω
Type F, 75Ω	
Type N, 50Ω	

**2.3 Front Panel Indicators** -The following are the front panel indicators.

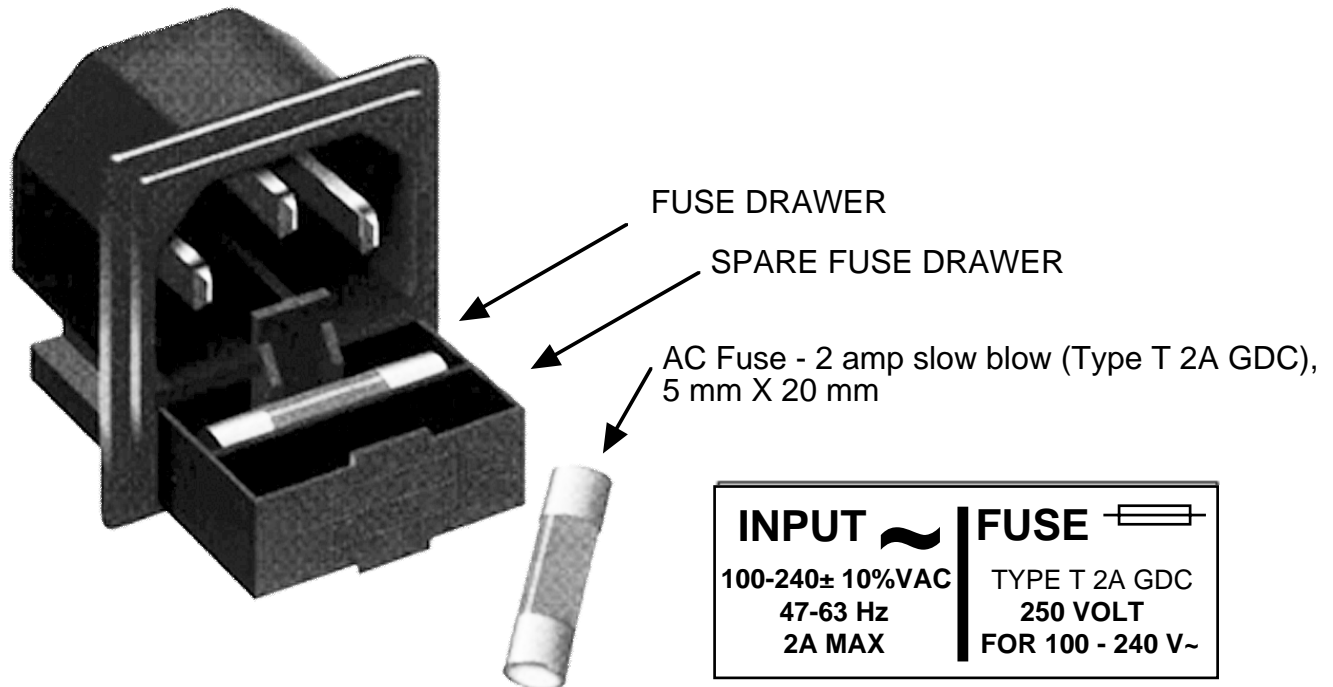

**FIGURE 2.2 2116-55 Front Panel Controls and Indicators**

## 2.4 Installation / Operation

### 2.4.1 Installing and Operating the 2116-55 Downconverter

- 1.) Connect a -55 dBm to -35 dBm signal to RF INPUT, J101 (Figure 2.1).
- 2.) Connect the L-BAND OUTPUT, J1, to the external equipment.
- 3.) Connect 100-240  $\pm$ 10% VAC, 47 - 63 Hz to AC connector on the back panel.
- 4.) Be sure DS1 (green, DC Power) is on and DS2 (red, Alarm) is off (Figure 2.2).
- 5.) Select either INT (for internal 10MHz ref), AUTO (for internal 10MHz ref UNLESS a external 10MHz, 0 dBm signal is connected to J2), or EXT (for external 10MHz, 0 dBm ref that is inserted at J2) on rear panel switch S1 (Figure 2.1).
- 6.) If EXT is selected or AUTO is selected and there is a 10MHz, 0 dBm signal at J2, check that DS3 (yellow, Ext 10MHZ) is on (Figure 2.2).
- 7.) Check that a 10MHz, 0 dBm  $\pm$ 3 dB signal is present at the 10MHZ REF OUTPUT (J8) (Figure 2.1).
- 8.) **AC Fuse** - The fuse is a 5 mm X 20 mm, 2 amp slow blow (Type T) and is inserted in the far slot in the drawer below the AC input as shown in Figure 2.3. There is a spare fuse in the near slot.  
If a fuse continues to open, the power supply is most likely defective.



**FIGURE 2.3 Fuse Location and Spare Fuse**





6170 Shiloh Road  
Alpharetta, Georgia 30005

(770) 886-8005  
FAX (770) 886-7964  
Toll Free 888-900-5588

WEB [www.crosstechnologies.com](http://www.crosstechnologies.com)  
E-MAIL [info@crosstechnologies.com](mailto:info@crosstechnologies.com)