

# Instruction Manual

# Model 2116-31T21 Block Translator

December 2019, Rev. 0



Data, drawings, and other material contained herein are proprietary to Cross Technologies, Inc., but may be reproduced or duplicated without the prior permission of Cross Technologies, Inc. for purposes of operating the equipment.

When ordering parts from Cross Technologies, Inc., be sure to include the equipment model number, equipment serial number, and a description of the part.



6170 Shiloh Road  
Alpharetta, Georgia 30005

(770) 886-8005  
FAX (770) 886-7964  
Toll Free 888-900-5588

WEB [www.crosstechnologies.com](http://www.crosstechnologies.com)  
E-MAIL [info@crosstechnologies.com](mailto:info@crosstechnologies.com)

# INSTRUCTION MANUAL

## MODEL 2116-31T21 Block Translator

<u>TABLE OF CONTENTS</u>	<u>PAGE</u>
<b>Warranty</b>	<b>2</b>
<b>1.0 General</b>	<b>3</b>
1.1 Equipment Description	<b>3</b>
1.2 Technical Characteristics	<b>4</b>
<b>2.0 Installation</b>	<b>5</b>
2.1 Mechanical	<b>5</b>
2.2 Rear Inputs and Outputs	<b>6</b>
2.3 Front Panel Indicators	<b>6</b>
2.4 Operation	<b>7</b>
<b>3.0 Environmental Use Information</b>	<b>8</b>

**WARRANTY** - The following warranty applies to all Cross Technologies, Inc. products.

All Cross Technologies, Inc. products are warranted against defective materials and workmanship for a period of one year after shipment to customer. Cross Technologies, Inc.'s obligation under this warranty is limited to repairing or, at Cross Technologies, Inc.'s option, replacing parts, subassemblies, or entire assemblies. Cross Technologies, Inc. shall not be liable for any special, indirect, or consequential damages. This warranty does not cover parts or equipment which have been subject to misuse, negligence, or accident by the customer during use. All shipping costs for warranty repairs will be prepaid by the customer. There are not other warranties, express or implied, except as stated herein.



6170 Shiloh Road  
Alpharetta, Georgia 30005

(770) 886-8005  
FAX (770) 886-7964  
Toll Free 888-900-5588

WEB [www.crosstechnologies.com](http://www.crosstechnologies.com)  
E-MAIL [info@crosstechnologies.com](mailto:info@crosstechnologies.com)

# MODEL 2116-31T21 Block Translator

## 1.0 General

### 1.1 Equipment Description

The 2116-31T21 Block Translator converts 30.0 - 31.0 GHz to 20.2 - 21.2 GHz with a local oscillator at 9.80 GHz. Front panel LEDs provide indication of DC Power, External 10 MHz, and PLL Alarm. The gain is -30 dB. Connectors are 2.92mm female for RF In, Super SMA female for RF Out and BNC female for the external reference input and reference output. A three-way switch controls which 10 MHz reference is being used. When in the AUTO position, the internal reference is used unless a +3 dBm  $\pm$  3 dB, 10MHz reference signal is connected to the external reference input. The 2116 is powered by a 100-240  $\pm$ 10% VAC power supply, and mounted in a 1 3/4" X 19" X 14" rack mount chassis.

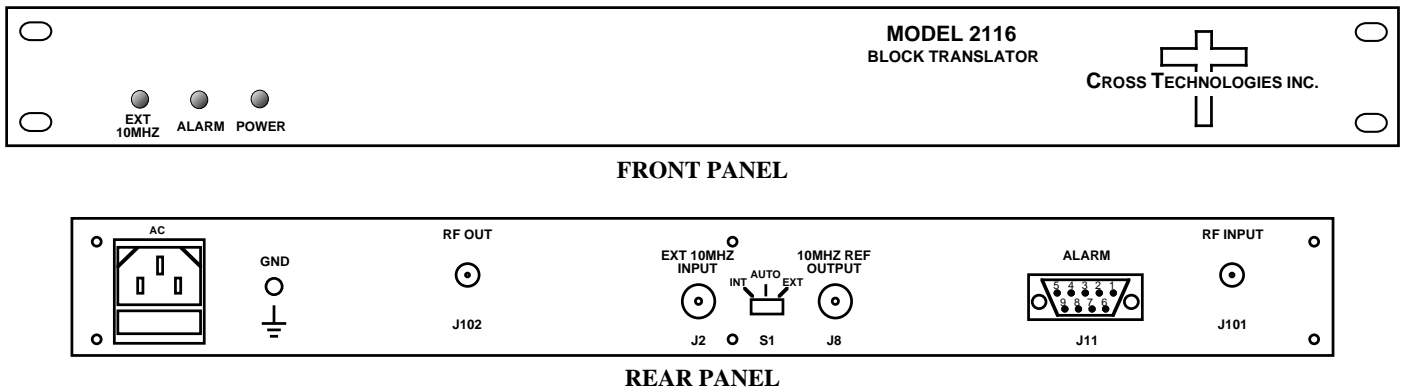

**FIGURE 1.1 Front and Rear Panels**

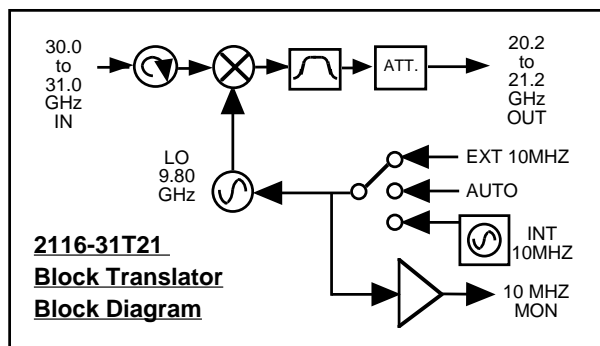

**FIGURE 1.2 Block Diagram**

## 1.2 Technical Characteristics

**TABLE 1.0 2116-31T21 Block Translator Specifications\***

### Input Characteristics

Impedance/Return Loss	50 $\Omega$ /14 dB min. (see TABLE 2.2 for connector options)
Frequency	30.0 to 31.0 GHz
Input Level Range	-30 to -10 dBm
Input 1dB Compression	0 dBm

### Output Characteristics

Impedance/Return Loss	50 $\Omega$ /15 dB, typ., 14 dB min. (see TABLE 2.2 for connector options)
Frequency	20.2 to 21.2 GHz
Output Level Range	-60 to -40 dBm
Output 1dB compression	-30 dBm

### Channel Characteristics

Gain	-30 dB $\pm$ 2 dB at Fc
Input/Output Isolation	>40 dB minimum
Intermodulation	>50 dBC for two carriers each at -15 dBm in
Spurious, Inband	SIGNAL RELATED<-50 dBC,typical -40 dBC max; SIGNAL INDEPENDENT<-80 dBm;
Frequency Response	$\pm$ 2.0 dB, over frequency band; $\pm$ 0.5 dB, 40 MHz BW
Frequency Sense	Non-inverting

### LO Characteristics

LO Frequency	9.80 GHz
Frequency Accuracy	$\pm$ 0.01 ppm max. over temp internal reference; ext. ref. input
10 MHz In/Out Level	+3 dBm $\pm$ 3 dB

Phase Noise @ Freq	10Hz	1kHz	10kHz	100kHz	1MHz
dBC/Hz	-70	-80	-85	-95	-110

### Controls, Indicators

Power	Green LED
PLL Alarm	Red LED, External contact closure
Ext 10 MHz	Yellow LED, indicates ext. 10 MHz ref. selected (rear panel DPDT switch)
10 MHz Reference	3-way Switch (selects INTERNAL, EXTERNAL, or AUTO mode)

### Other

RF In/RF Out Connectors	2.92 mm / Super SMA
10 MHz Connectors	BNC (female), 50 $\Omega$ /75 $\Omega$
Alarm Connector	DB9 (female) - NO or NC contact closure on alarm
Size	19 inch, 1RU standard chassis 1.75" High X 14.0" Deep
Power	100-240 $\pm$ 10 VAC, 47-63 Hz, 45 watts max.

### Options

Connector Options	See TABLE 2.2
-------------------	---------------

---

\*0°C to +40°C; Specifications subject to change without notice.

## 2.0 Installation

### 2.1 Mechanical

The 2116-31T21 consists of one RF PCB housed in a 1 RU (1 3/4 inch high) by 14 inch deep chassis. A switching,  $\pm 12$ , +24, +5 VDC power supply provides power for the assemblies. The 2116-31T21 can be secured to a rack using the 4 holes on the front panel. Figure 2.0 shows how the 2116-31T21 is assembled.

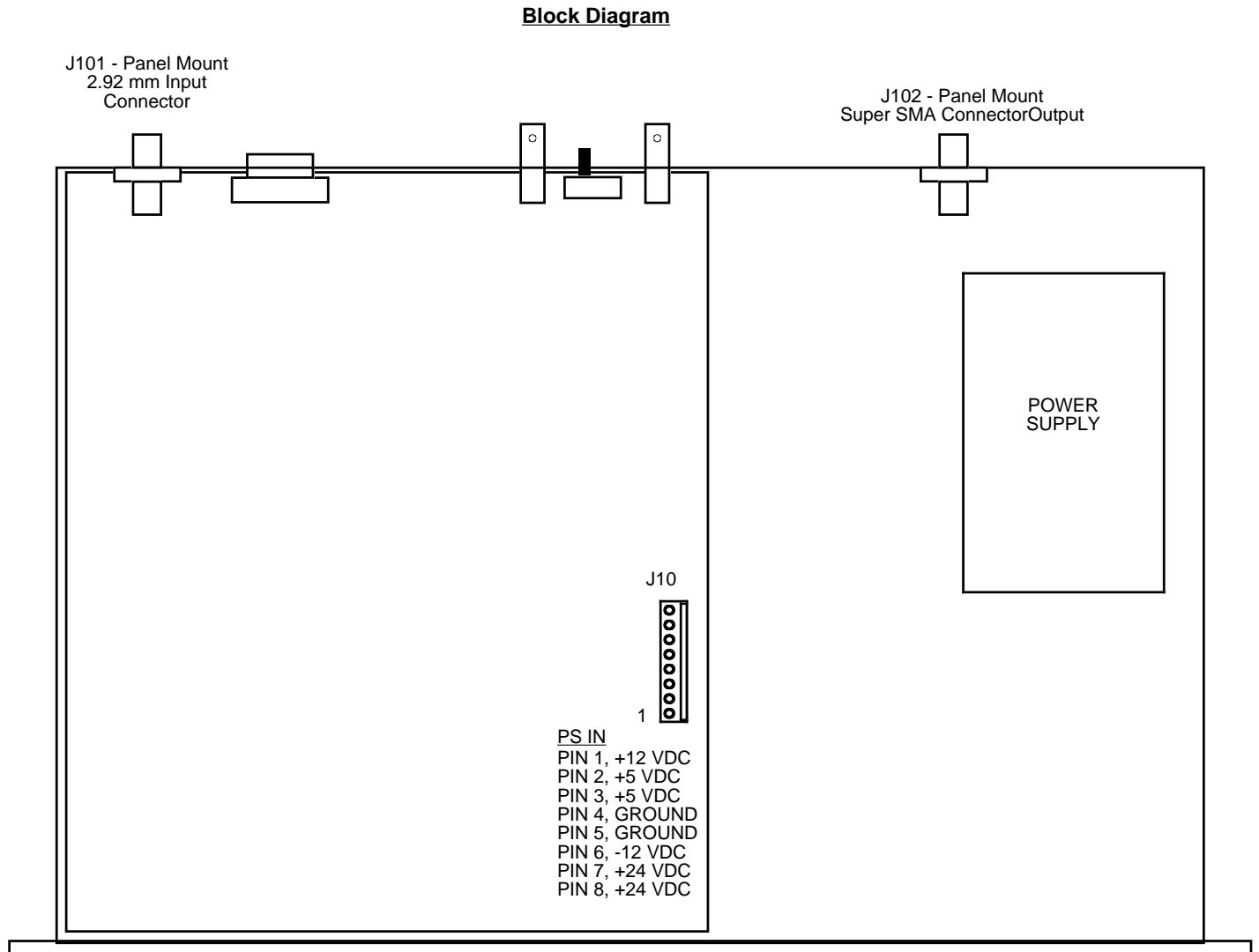

**FIGURE 2.0 2116-31T21 Mechanical Assembly**

## 2.2 Rear Panel Input/Output Signals

Figure 2.1 shows the input and output connectors on the rear panel.

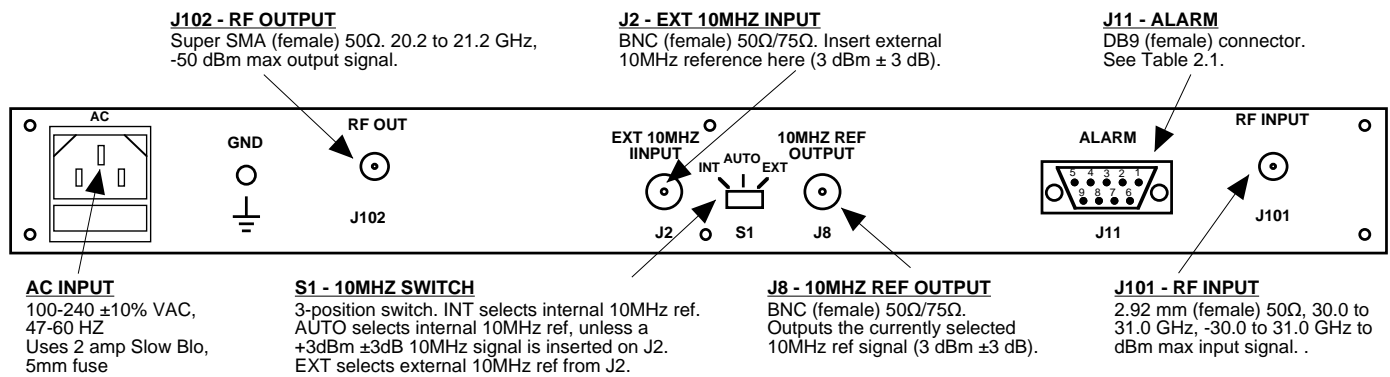

**FIGURE 2.1 2116-31T21 Rear Panel I/O's**

Pin	Function
1	Not Used
2	Not Used
3	Not Used
4	Not Used
5	GND
6	Alarm Relay: Common
7	Alarm Relay: Normally Open
8	Not Used
9	Alarm Relay: Normally Closed

	RF Input	RF Output
STD	2.92 mm	Super SMA, 50Ω

## 2.3 Front Panel Indicators

Figure 2.2 shows the front panel indicators.

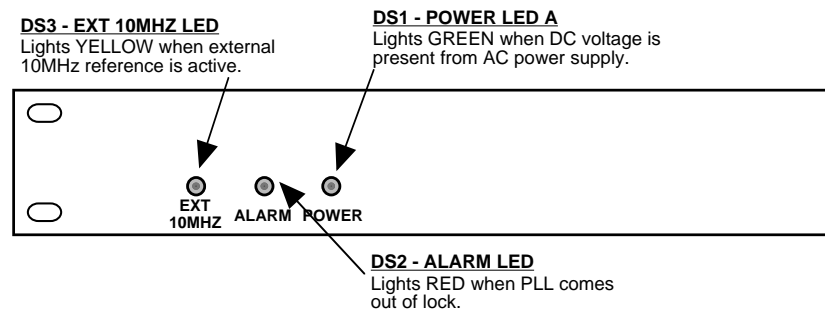
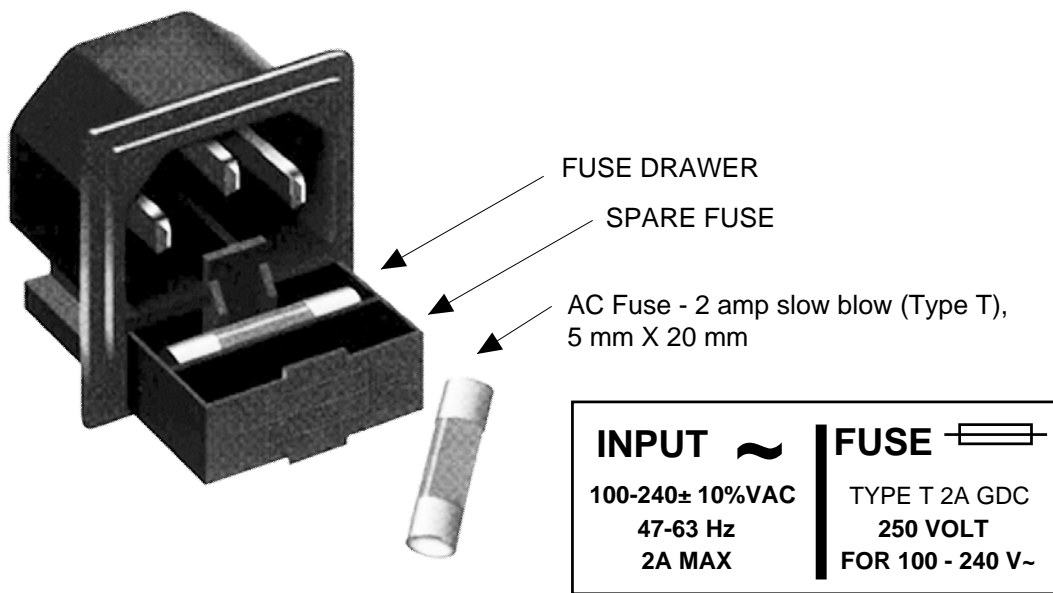

**FIGURE 2.2 2116-31T21 Front Panel Controls and Indicators**

## 2.4 Installation / Operation

### 2.4.1 Installing and Operating the 2116-31T21 Block Translator

1. Connect a -30 dBm to -10 dBm (30.0 to 31.2) GHz signal to RF INPUT (J101) (Figure 2.1).
2. Connect RF OUT (20.2 to 21.2 GHz, (J102) to the external equipment.
3. Connect a 100-240  $\pm$ 10% VAC, 47 - 63 Hz to AC connector on the back panel.
4. Be sure DS1 (green, DC Power) is on and DS2 (red, Alarm) is off (Figure 2.2).
5. Select either INT. (for internal 10MHz ref), AUTO (for internal 10MHz ref UNLESS an external 10MHz, 3 dBm signal is connected to J2), or EXT (for external 10MHz, 3 dBm ref that is inserted at J2) using the rear panel 3-way switch, S1 (Figure 2.1).
6. If EXT is selected or AUTO is selected and there is a 10MHz, 3 dBm signal at J2, check that DS3 (yellow, Ext 10MHZ) is on (Figure 2.2).
7. Check that a 10MHz, 3 dBm  $\pm$ 3 dB signal is present at the 10MHZ REF OUTPUT (J8) (Figure 2.1).
8. AC Fuse - The fuse is a 5 mm X 20 mm, 2 amp slow blow (Type T) and is inserted in the far slot in the drawer below the AC input as shown in Figure 2.3. There is a spare fuse in the near slot. If a fuse continues to open, the power supply is most likely defective.



**FIGURE 2.3 Fuse Location and Spare Fuse**

### 3.0 Environmental Use Information

- A. **Rack-Mounting** - To mount this equipment in a rack, please refer to the installation instructions located in the user manual furnished by the manufacturer of your equipment rack.
- B. **Mechanical loading** - Mounting of equipment in a rack should be such that a hazardous condition does not exist due to uneven weight distribution.
- C. **Elevated operating ambient temperature** - If installed in a closed or multi-unit rack assembly, the operating ambient temperature of the rack may be greater than room ambient temperature. Therefore, consideration should be given to Tmra.
- D. **Reduced air flow** - Installation of the equipment in a rack should be such that the amount of air flow required for safe operation of the equipment is not compromised. Additional space between units may be required.
- E. **Circuit Overloading** - Consideration should be given to the connection of the equipment to the supply circuit and the effect that overloading of circuits could have on over current protection and supply wiring. Appropriate consideration of equipment name plate rating should be used, when addressing this concern.
- F. **Reliable Earthing** - Reliable earthing of rack-mounted equipment should be maintained. Particular attention should be given to supply connections other than direct connection to the Branch (use of power strips).
- G. **Top Cover** - There are no serviceable parts inside the product so, the Top Cover should not be removed. If the Top Cover is removed the ground strap and associated screw **MUST BE REINSTALLED** prior to Top Cover screw replacement. **FAILURE TO DO** this may cause **INGRESS** and/or **EGRESS** emission problems.





6170 Shiloh Road  
Alpharetta, Georgia 30005

(770) 886-8005  
FAX (770) 886-7964  
Toll Free 888-900-5588

WEB [www.crosstechnologies.com](http://www.crosstechnologies.com)  
E-MAIL [info@crosstechnologies.com](mailto:info@crosstechnologies.com)

PRINTED IN USA