

Instruction Manual

Model 2116-182193 Block Downconverter

February 2023, Rev. 0

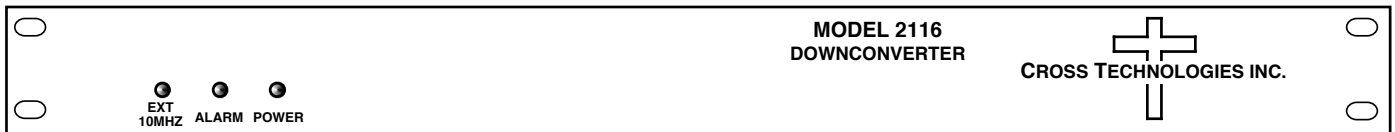

Data, drawings, and other material contained herein are proprietary to Cross Technologies, Inc., but may be reproduced or duplicated without the prior permission of Cross Technologies, Inc. for purposes of operating the equipment. Printed in USA.

When ordering parts from Cross Technologies, Inc., be sure to include the equipment model number, equipment serial number, and a description of the part.



6170 Shiloh Road
Alpharetta, Georgia 30005

(770) 886-8005
FAX (770) 886-7964
Toll Free 888-900-5588

WEB www.crosstechnologies.com
E-MAIL info@crosstechnologies.com

INSTRUCTION MANUAL

MODEL 2116-182193 Downconverter

| <u>TABLE OF CONTENTS</u> | <u>PAGE</u> |
|--|--------------------|
| Warranty | 2 |
| 1.0 General | 3 |
| 1.1 Equipment Description | 3 |
| 1.2 Technical Characteristics | 4 |
| 2.0 Installation | 6 |
| 2.1 Mechanical | 6 |
| 2.2 Rear Inputs and Outputs | 7 |
| 2.3 Front Panel Indicators | 7 |
| 2.4 Operation | 8 |
| 3.0 Environmental Use Information | 9 |

WARRANTY - The following warranty applies to all Cross Technologies, Inc. products.

All Cross Technologies, Inc. products are warranted against defective materials and workmanship for a period of one year after shipment to customer. Cross Technologies, Inc.'s obligation under this warranty is limited to repairing or, at Cross Technologies, Inc.'s option, replacing parts, subassemblies, or entire assemblies. Cross Technologies, Inc. shall not be liable for any special, indirect, or consequential damages. This warranty does not cover parts or equipment which have been subject to misuse, negligence, or accident by the customer during use. All shipping costs for warranty repairs will be prepaid by the customer. There are not other warranties, express or implied, except as stated herein.



6170 Shiloh Road
Alpharetta, Georgia 30005

(770) 886-8005
FAX (770) 886-7964
Toll Free 888-900-5588

WEB www.crosstechnologies.com
E-MAIL info@crosstechnologies.com

MODEL 2116-182193 Downconverter

1.0 General

1.1 Equipment Description - The 2116-182193 Downconverter converts **18.2 - 19.3 GHz** to **0.95 - 2.05 GHz** with a local oscillator at **17.25 GHz**. Front panel LEDs indicate DC Power, External 10 MHz, and PLL Alarm. The gain is **+25 dB**. Connectors are **SuperSMA** female for the RF input and BNC female for the RF output (designated L-Band), the external reference input, and the reference output. A three-way switch controls which 10 MHz reference is being used. In the INT position, the internal reference is used, in the EXT position, the external reference is used, and in the AUTO position, the internal reference is used unless a +3 dBm \pm 3 dB, 10MHz reference signal is connected to the external reference input. It is powered by a 100-240 \pm 10% VAC power supply, and in a 1 3/4" X 19" X 14" rack mount chassis.

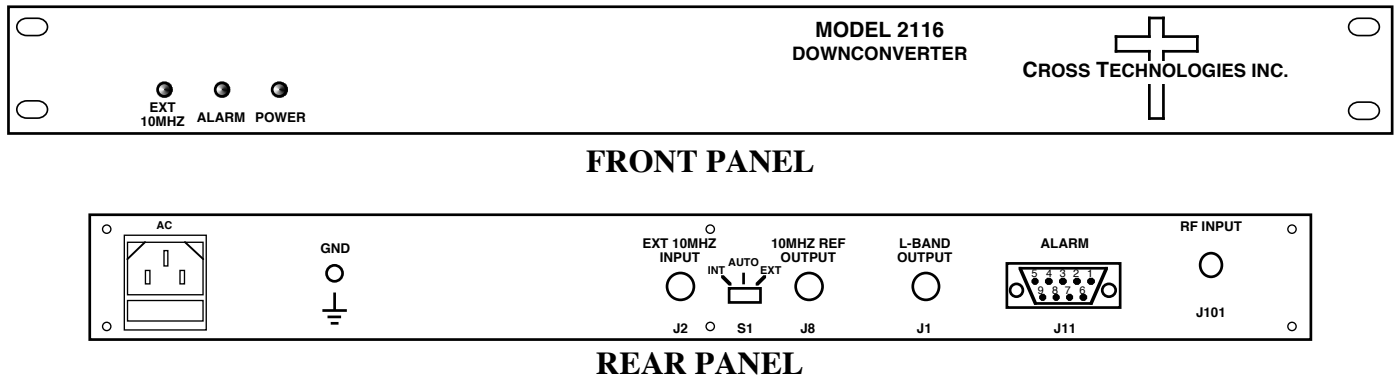

FIGURE 1.1 Model 2116-182193 Front and Rear Panels

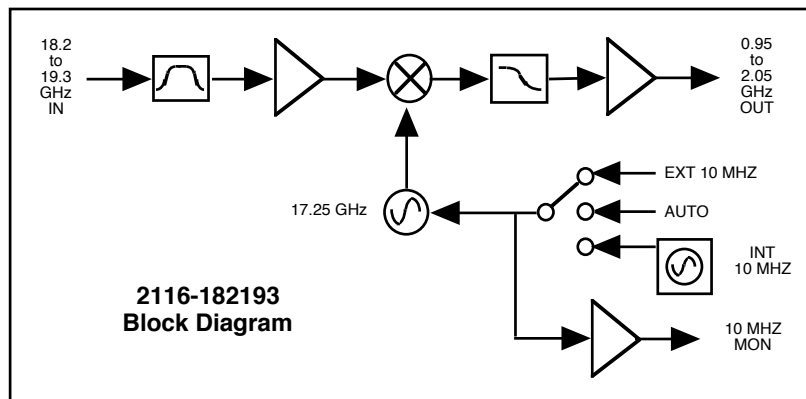

FIGURE 1.2 Model 2116-182193 Downconverter Block Diagram

1.2 Technical Characteristics

TABLE 1.0 2116-182193 Downconverter Specifications*

Input Characteristics (RF)

| | |
|-----------------------|--|
| Impedance/Return Loss | 50 Ω /14 dB (See TABLE 2.2 for connector options) |
| Frequency | 18.2 to 19.3 GHz |
| Noise Figure, max. | 12 dB, max. gain |
| Input Level | -55 to -35 dBm |
| Input 1dB Compression | -25 dBm |

Output Characteristics (L-Band)

| | |
|-------------------------|--------------------|
| Impedance/Return Loss | 50 Ω /14 dB |
| Frequency | 0.95 to 2.05 GHz |
| Output Level Range | -30 to -10 dBm |
| Output 1 dB compression | +0 dBm at Fc, Gmax |

Channel Characteristics

| | |
|-----------------------|--|
| Gain | +25 dB \pm 2 dB at Fc |
| Image Rejection | >55 dB, min. |
| Spurious, In Band | SIGNAL RELATED <-50 dBc in band, -10 dBm out; SIGNAL INDEPENDENT, <-60 dBm, 0.95-2.05 GHz Out |
| Spurious, Out of Band | <-50 dBm (0.5-0.94 GHz and 2.06-3.3 GHz Out), Gmax |
| Intermodulation | <-55 dBc for two carriers at Fc \pm 2 MHz, each at -15 dBm out, Gmax |
| Frequency Response | \pm 2.0 dB, 0.95 to 2.05 GHz out; \pm 0.5 dB, 40 MHz BW |
| Frequency Sense | Non-Inverting |

LO Characteristics

| | |
|--------------------|--|
| LO Frequency | 17.25 GHz |
| Frequency Accuracy | \pm 0.01 ppm max over temp internal reference, |
| 10 MHz Level | 3 dBm, \pm 3 dB, 75 ohms, External In or 10MHz Out |

Controls, Indicators

| | |
|---------------------|--|
| INT/AUTO/EXT Switch | Selects internal or external 10 MHz (rear panel DP3T switch) |
| Power | Green LED |
| PLL Alarm | Red LED, External contact closure |
| Ext 10 MHz | Yellow LED, Indicates Ext 10 MHz reference selected |

Other

| | |
|-------------------|--|
| RF Connector | Super SMA (female), 50 Ω |
| L-Band Connector | BNC (female), 50 Ω |
| 10 MHz Connectors | BNC (female), 50 Ω /75 Ω |
| Alarm Connector | DB9 - NO or NC contact closure on Alarm |
| Size | 19 inch standard chassis, 1.7" high X 14.0" deep |
| Power | 100 - 240 \pm 10% VAC, 47 - 63 Hz, 45 watts max. |

Options

| | |
|-------------------|---------------|
| Connector Options | See TABLE 2.2 |
|-------------------|---------------|

*+10°C to +40°C; Specifications subject to change without notice.

2.0 Installation

2.1 Mechanical - The 2116-182193 consists of one RF PCB housed in a 1 RU (1 3/4 inch high) by 14 inch deep chassis. A switching, ± 12 , +24, +5 VDC power supply provides power for the assemblies. The 2116-182193 can be secured to a rack using the 4 holes on the front panel. Figure 2.0 shows how the 2116-182193 is assembled.

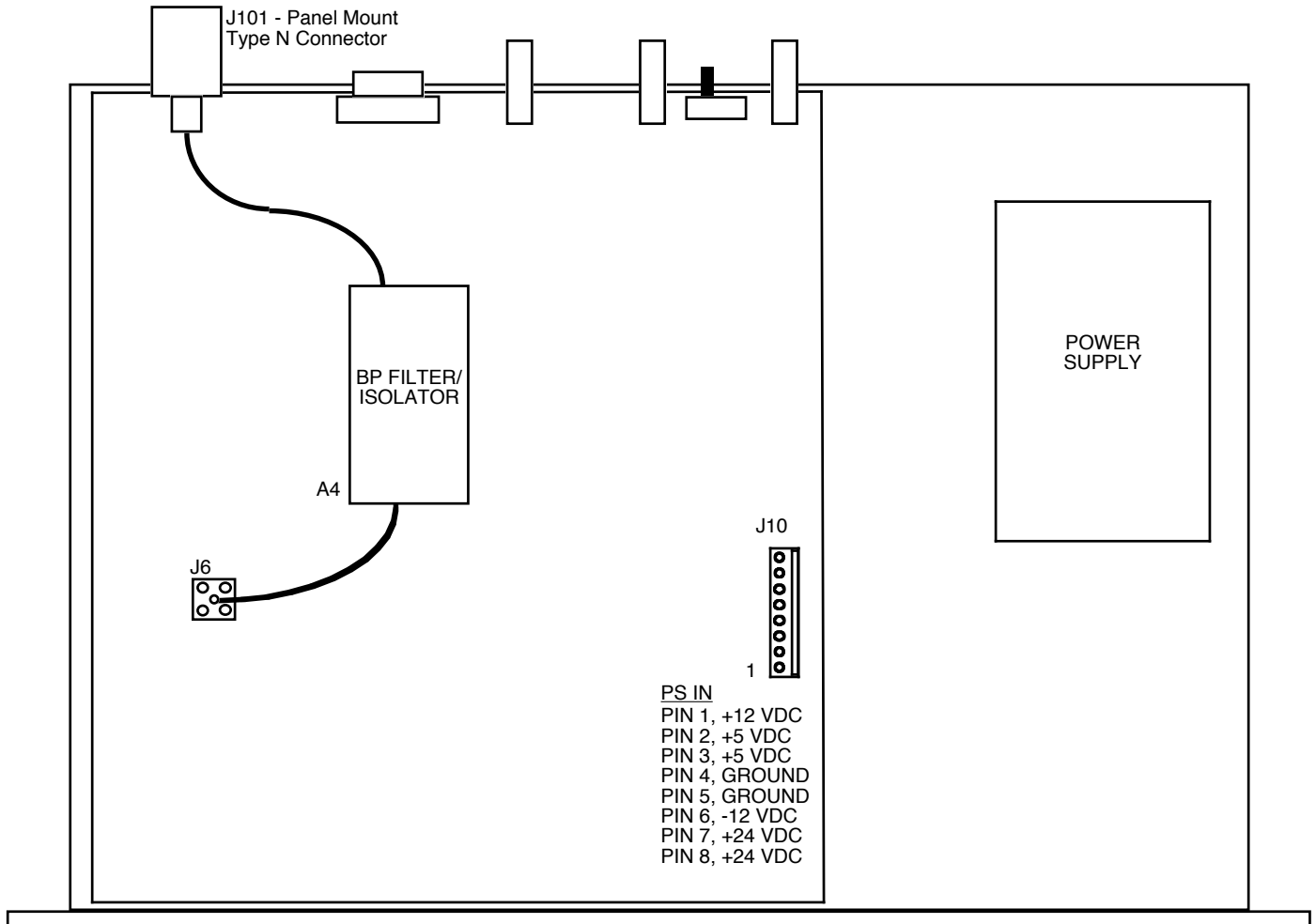

FIGURE 2.0 2116-182193 Mechanical Assembly

2.2 Rear Panel Input/Output Signals - Figure 2.1 shows the input and output connectors on the rear panel.

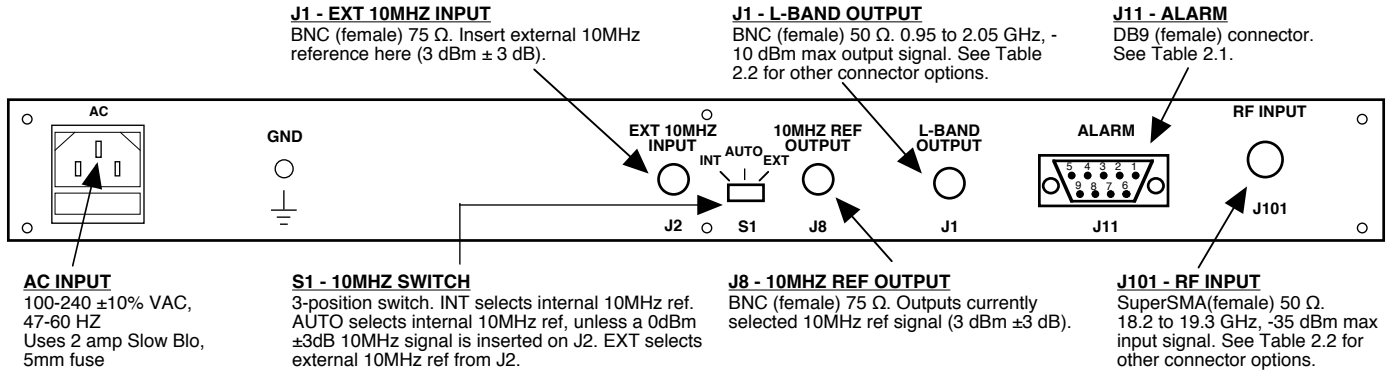

FIGURE 2.1 2116-182193 Rear Panel I/O's

TABLE 2.1 J11 Pinouts (DB9)

| Pin | Function |
|-----|------------------------------|
| 1 | Not Used |
| 2 | Not Used |
| 3 | Not Used |
| 4 | Not Used |
| 5 | GND |
| 6 | Alarm Relay: Common |
| 7 | Alarm Relay: Normally Open |
| 8 | Not Used |
| 9 | Alarm Relay: Normally Closed |

TABLE 2.2 Connector Options

| L-Band | RF |
|----------------|---------------------|
| BNC, 50Ω (STD) | SuperSMA, 50Ω (STD) |
| BNC, 75Ω | |
| Type F, 75Ω | |
| Type N, 50Ω | |

2.3 Front Panel Indicators - The following are the front panel indicators.

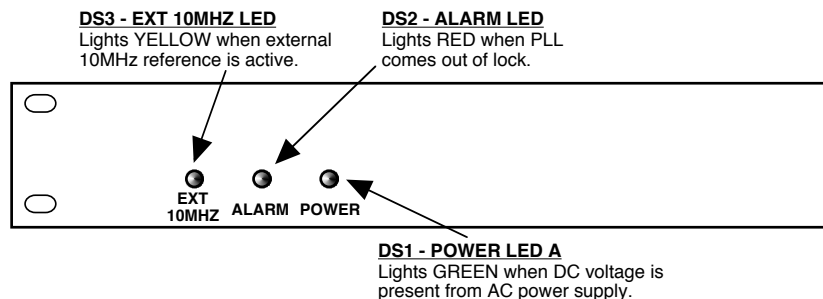

FIGURE 2.2 2116-182193 Front Panel Controls and Indicators

2.4 Installation / Operation

2.4.1 Installing and Operating the 2116-182193 Downconverter

- 1.) Connect a -55 dBm to -35 dBm signal to RF INPUT, J101 (Figure 2.1).
- 2.) Connect the L-BAND OUTPUT, J1, to the external equipment.
- 3.) Connect 100-240 \pm 10% VAC, 47 - 63 Hz to AC connector on the back panel.
- 4.) Be sure DS1 (green, DC Power) is on and DS2 (red, Alarm) is off (Figure 2.2).
- 5.) Select either INT (for internal 10MHz ref), AUTO (for internal 10MHz ref UNLESS a external 10MHz, 0 dBm signal is connected to J2), or EXT (for external 10MHz, 0 dBm ref that is inserted at J2) on rear panel switch S1 (Figure 2.1).
- 6.) If EXT is selected or AUTO is selected and there is a 10MHz, 0 dBm signal at J2, check that DS3 (yellow, Ext 10MHZ) is on (Figure 2.2).
- 7.) Check that a 10MHz, 0 dBm \pm 3 dB signal is present at the 10MHZ REF OUTPUT (J8) (Figure 2.1).
- 8.) **AC Fuse** - The fuse is a 5 mm X 20 mm, 2 amp slow blow (Type T) and is inserted in the far slot in the drawer below the AC input as shown in Figure 2.3. There is a spare fuse in the near slot.
If a fuse continues to open, the power supply is most likely defective.

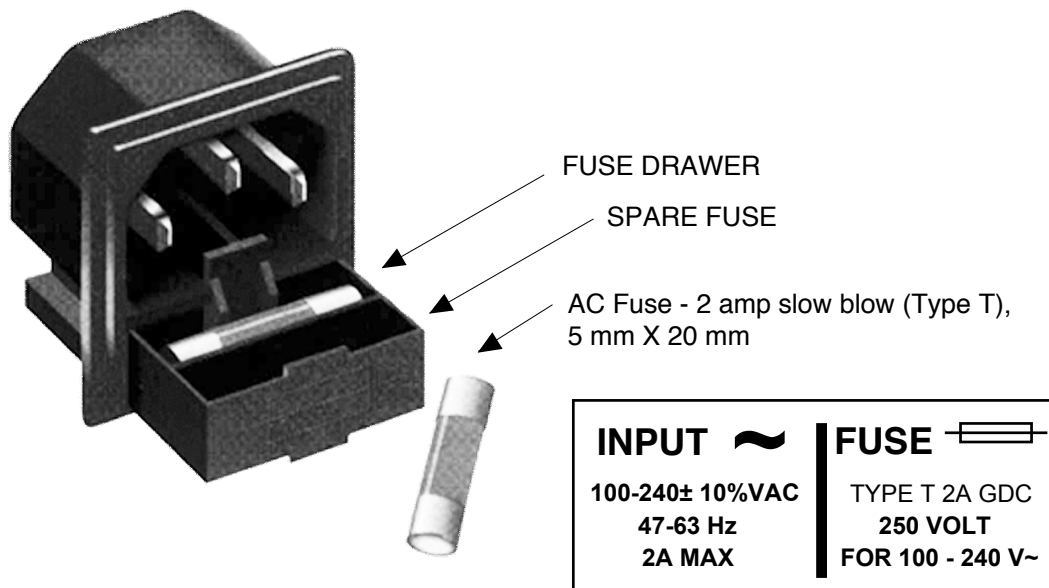

FIGURE 2.3 Fuse Location and Spare Fuse

3.0 Environmental Use Information

- A. Rack-Mounting** - To mount this equipment in a rack, please refer to the installation instructions located in the user manual furnished by the manufacturer of your equipment rack.
- B. Mechanical Loading** - Mounting of equipment in a rack should be such that a hazardous condition does not exist due to uneven weight distribution.
- C. Elevated Operating Ambient Temperature** - If installed in a closed or multi-unit rack assembly, the operating ambient temperature of the rack may be greater than room ambient temperature. Therefore, consideration should be given to Tmra.
- D. Reduced Air Flow** - Installation of the equipment in a rack should be such that the amount of air flow required for safe operation of the equipment is not compromised. Additional space between unit may be required.
- E. Circuit Overloading** - Consideration should be given to the connection of the equipment to the supply circuit and the effect that overloading of circuits could have on over current protection and supply wiring. Appropriate consideration of equipment name plate rating should be used, when addressing this concern.
- F. Reliable Earthing** - Reliable earthing of rack-mounted equipment should be maintained. Particular attention should be given to supply connections other than direct connection to the Branch (use of power strips).
- G. Top Cover** - There are no serviceable parts inside the product so, the Top Cover should not be removed. If the Top Cover is removed the ground strap and associated screw **MUST BE REINSTALLED** prior to Top Cover screw replacement. **FAILURE TO DO** this may cause **INGRESS** and/or **EGRESS** emission problems.



6170 Shiloh Road
Alpharetta, Georgia 30005

(770) 886-8005
FAX (770) 886-7964
Toll Free 888-900-5588

WEB www.crosstechnologies.com
E-MAIL info@crosstechnologies.com

Printed in USA