

Instruction Manual

Model 2115-310-1600

Block Upconverter

December 15, 2021 Rev. 0



Data, drawings, and other material contained herein are proprietary to Cross Technologies, Inc., but may be reproduced or duplicated without the prior permission of Cross Technologies, Inc. for purposes of operating the equipment.

When ordering parts from Cross Technologies, Inc., be sure to include the equipment model number, equipment serial number, and a description of the part.



6170 Shiloh Road
Alpharetta, Georgia 30005

(770) 886-8005
FAX (770) 886-7964
Toll Free 888-900-5588

WEB www.crosstechnologies.com
E-MAIL info@crosstechnologies.com

INSTRUCTION MANUAL

MODEL 2115-310-1600 Block Upconverter

<u>TABLE OF CONTENTS</u>	<u>PAGE</u>
Warranty	2
1.0 General	3
1.1 Equipment Description	3
1.2 Technical Characteristics	4
2.0 Installation	5
2.1 Mechanical	5
2.2 Rear Inputs and Outputs	6
2.3 Front Panel Indicators	6
2.4 Operation	7
2.5 Environmental Use Information	8

WARRANTY - The following warranty applies to all Cross Technologies, Inc. products.

All Cross Technologies, Inc. products are warranted against defective materials and workmanship for a period of one year after shipment to customer. Cross Technologies, Inc.'s obligation under this warranty is limited to repairing or, at Cross Technologies, Inc.'s option, replacing parts, subassemblies, or entire assemblies. Cross Technologies, Inc. shall not be liable for any special, indirect, or consequential damages. This warranty does not cover parts or equipment which have been subject to misuse, negligence, or accident by the customer during use. All shipping costs for warranty repairs will be prepaid by the customer. There are not other warranties, express or implied, except as stated herein.



6170 Shiloh Road
Alpharetta, Georgia 30005

(770) 886-8005
FAX (770) 886-7964
Toll Free 888-900-5588

WEB www.crosstechnologies.com
E-MAIL info@crosstechnologies.com

MODEL 2115-310-1600 Block Upconverter

1.0 General

1.1 Equipment Description

The 2115-310-1600 Block Upconverter converts 1100 - 2100 MHz ($F_c=1600$ MHz) to 30.0 - 31.0 GHz with a local oscillator at 28.90 GHz. Front panel LEDs indicate DC Power, External 10 MHz, and PLL Alarm. The gain is +0 dB. Connectors are 2.92 mm female for the RF out and BNC female for the RF in (designated L-Band) and external reference input and reference output. A three-way switch controls which 10 MHz reference is being used. In the INT position, the internal reference is used, in the EXT position, the external reference is used, and in the AUTO position, the internal reference is used unless a +3 dBm \pm 3 dB, 10MHz reference signal is connected to the external reference input. It is powered by a 100-240 \pm 10% VAC power supply, and in a 1 3/4" X 19" X 14" rack mount chassis.

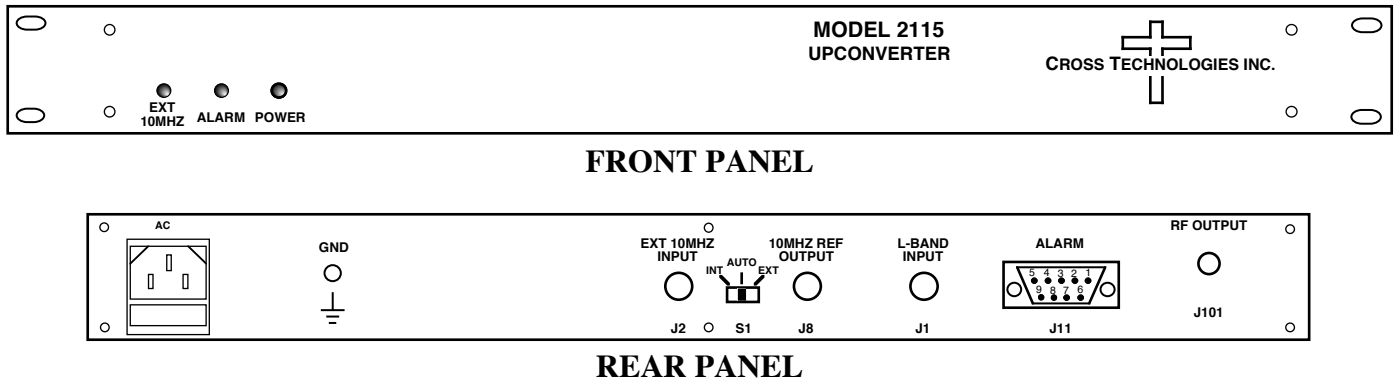

FIGURE 1.1 Model 2115-310-1600 Front & Rear Panels

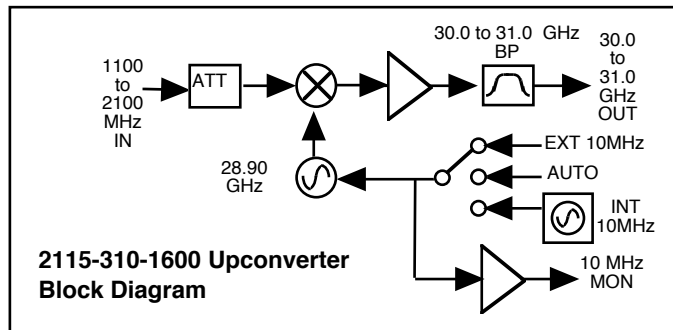

FIGURE 1.2 Model 2115-310-1600 Upconverter Block Diagram

1.2 Technical Characteristics

TABLE 1.1 2115-310-1600 Block Upconverter Specifications*					
Input Characteristics (designated L-Band)					
Impedance / Return Loss	50Ω / 14 dB				
Frequency	1100 to 2100 GHz				
Noise Figure, Maximum	20 dB maximum gain				
Input Level Range	-30 to -10 dBm				
Input 1 dB Compression	+0 dBm				
Output Characteristics (RF)					
Impedance / Return Loss	50Ω / 14 dB				
Frequency	30.0 to 31.0 GHz				
Output Level Range	-30 to -10 dBm				
Output 1 dB Compression	+0 dBm				
Channel Characteristics					
Gain	+0 ±1 dB at Fc				
Image Rejection	> 55 dB, minimum				
Spurious, Inband	SIGNAL RELATED <-55 dBc in band, -10 dBm out; SIGNAL INDEPENDENT, <-60 dBm;				
Spurious, Out of Band	<-60 dBm, 25.0-29.9 and 31.1-35.0 GHz out				
Intermodulation	< -50 dBc for two carriers at Fc ±2 MHz each at -15 dBm out				
Frequency Response	±2.0 dB, 30.0 - 31.0 MHz out; ± 0.5 dB, 40 MHz BW				
Frequency Sense	Non-inverting				
LO Characteristics					
LO Frequency	28.90 GHz				
Frequency Accuracy	± 0.01 ppm maximum over temp internal reference; external reference input				
10 MHz Level	3 dBm, ±3 dB, 75 ohms, External In or Internal Out				
Phase Noise @ F (Hz) >	100 MHz	1kHz	10kHz	100kHz	1MHz
dBc/Hz	-60	-70	-80	-90	-100
Controls, Indicators					
INT / AUTO / EXT Switch	Selects Internal or External 10 MHz (Rear Panel DP3T Switch)				
External 10 MHz	Yellow LED, Indicates External 10 MHz Reference Selected				
PLL Alarm	Red LED, External Contact Closure				
Power	Green LED				
Other					
RF In Connector	BNC (female), 50Ω (designated L-Band)				
RF Out Connector	2.92 mm (female), 50Ω				
10 MHz Connectors	BNC (female), 75Ω Connector; Works for 50Ω or 75Ω				
Alarm Connector	DB9 - NO or NC Contact Closure on Alarm				
Size	19 inch, Standard Chassis 1.75" high X 14.0" deep				
Power	100-24 ±10% VAC, 47-63 Hz, 25 watts maximum				
Available Options					
- 297	50Ω 2.92 (RF), 75Ω BNC (L-Band)				
- 29N	50Ω 2.92 (RF), 50Ω N-Type (L-Band)				
- 29S	50Ω 2.92 (RF), 50Ω SMA (L-Band)				
*+0 to +40 degrees C; Specifications subject to change without notice.					
© 2021 Cross Technologies, Inc.					

2.0 Installation

2.1 Mechanical - The 2115-310-1600 consists of one RF PCB housed in a 1 RU (1 3/4 inch high) by 14 inch deep chassis. A switching, ± 12 , +24, +5 VDC power supply provides power for the assemblies.

The 2115-310-1600 can be secured to a rack using the 4 holes on the front panel. Figure 2.0 shows how the 2115-310-1600 is assembled.

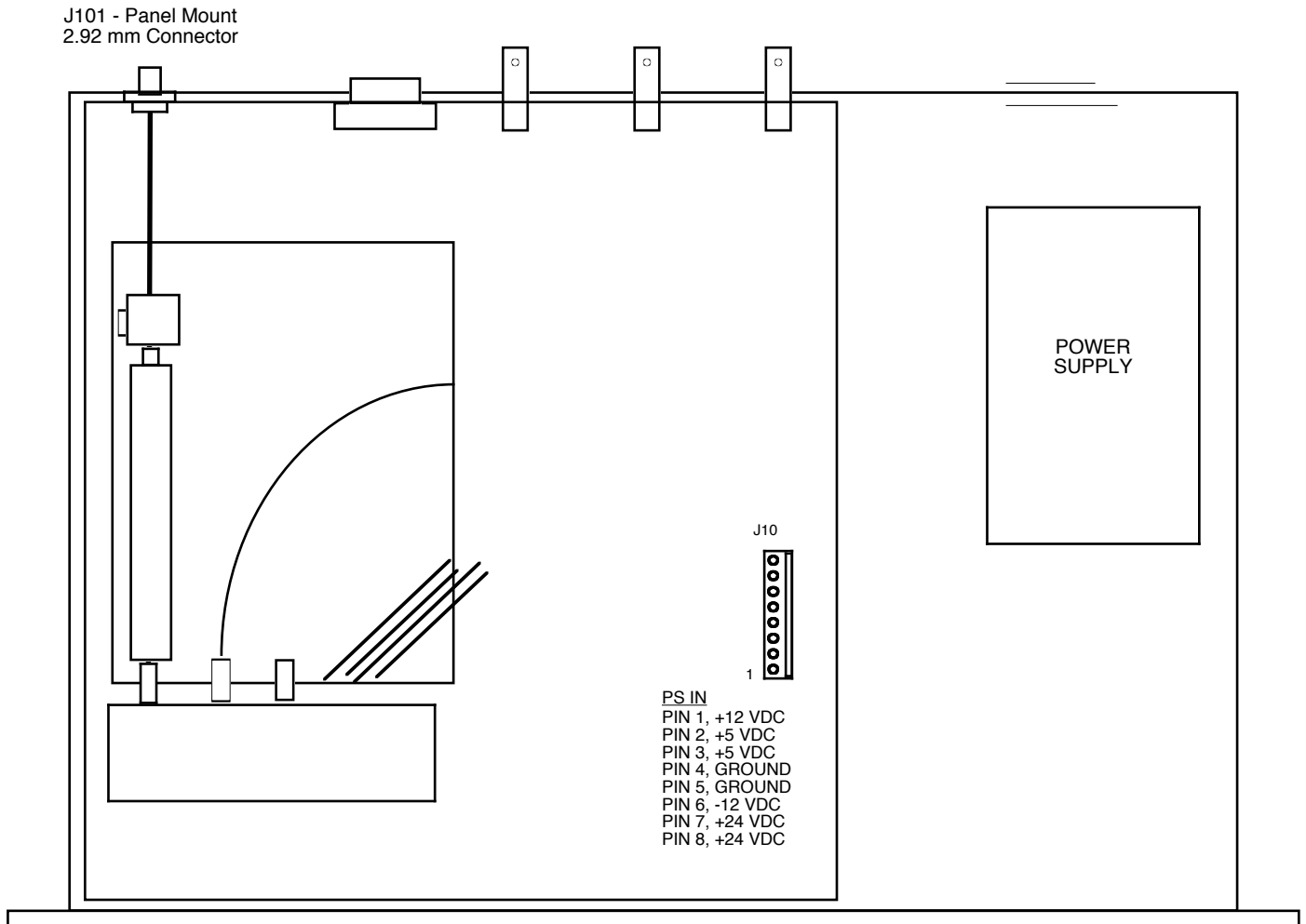

FIGURE 2.0 2115-310-1600 Mechanical Assembly

2.2 Rear Panel Input/Output Signals - Figure 2.1 shows the input and output connectors on the rear panel.

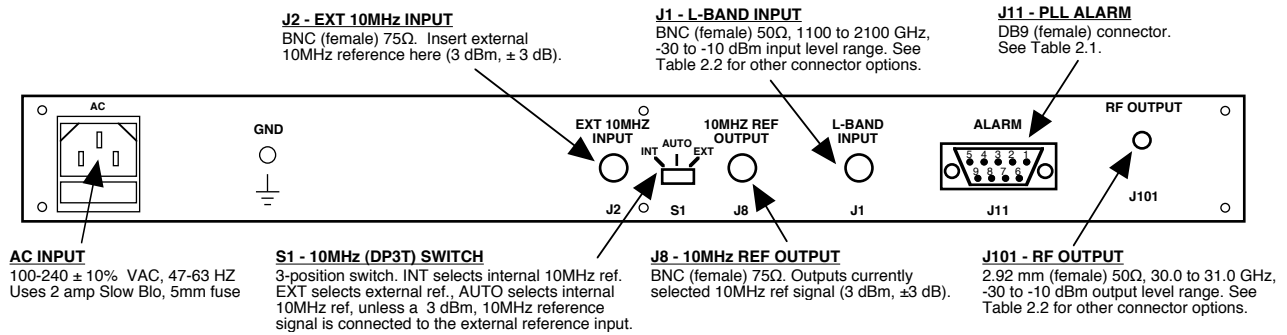

FIGURE 2.1 2115-310-1600 Rear Panel I/O's

TABLE 2.1 J11 Pinouts (DB9)	
Pin	Function
1	Not Used
2	Not Used
3	Not Used
4	Not Used
5	GND
6	Alarm Relay: Common
7	Alarm Relay: Normally Open
8	Not Used
9	Alarm Relay: Normally Closed

TABLE 2.2 Connector Options		
Option	L-Band	RF
Standard	BNC, 50Ω (STD)	2.92 mm, 50Ω (STD)
297	BNC, 75Ω	2.92 mm, 50Ω
29F	F-Type, 75Ω	2.92 mm, 50Ω
29N	N-Type, 50Ω	2.92 mm, 50Ω
29S	SMA, 50Ω	2.92 mm, 50Ω

2.3 Front Panel Indicators -The following are the front panel indicators.

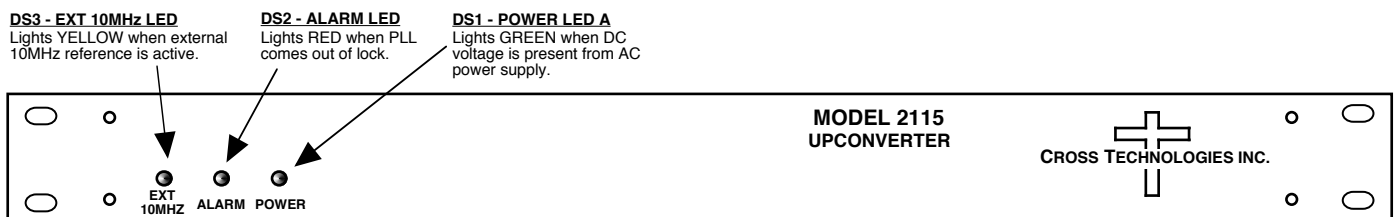

FIGURE 2.2 2115-310-1600 Front Panel Controls and Indicators

2.4 Installation / Operation

2.4.1 Installing and Operating the 2115-310-1600 Upconverter

1. Connect a -30 dBm to -10 dBm signal to L-BAND INPUT, J1 (Figure 2.1).
2. Connect the RF OUTPUT, J101, to the external equipment.
3. Connect 100-240 \pm 10% VAC, 47 - 63 Hz to AC connector on the back panel.
4. Be sure DS1 (green, DC Power) is on and DS2 (red, Alarm) is off (Figure 2.2).
5. Select either INT (for internal 10MHz ref), AUTO (for internal 10MHz ref UNLESS a external 10MHz, 3 dBm signal is connected to J2), or EXT (for external 10MHz, 3 dBm ref that is inserted at J2) on rear panel switch S1 (Figure 2.1).
6. If EXT is selected or AUTO is selected and there is a 10MHz, 3 dBm signal at J2, check that DS3 (yellow, Ext 10MHz) is on (Figure 2.2).
7. Check that a 10MHz, 3 dBm \pm 3 dB signal is present at the 10MHz REF OUTPUT (J8) (Figure 2.1).
8. AC Fuse - The fuse is a 5 mm X 20 mm, 2 amp slow blow (Type T) and is inserted in the far slot in the drawer below the AC input as shown in Figure 2.3. There is a spare fuse in the near slot. If a fuse continues to open, the power supply is most likely defective.

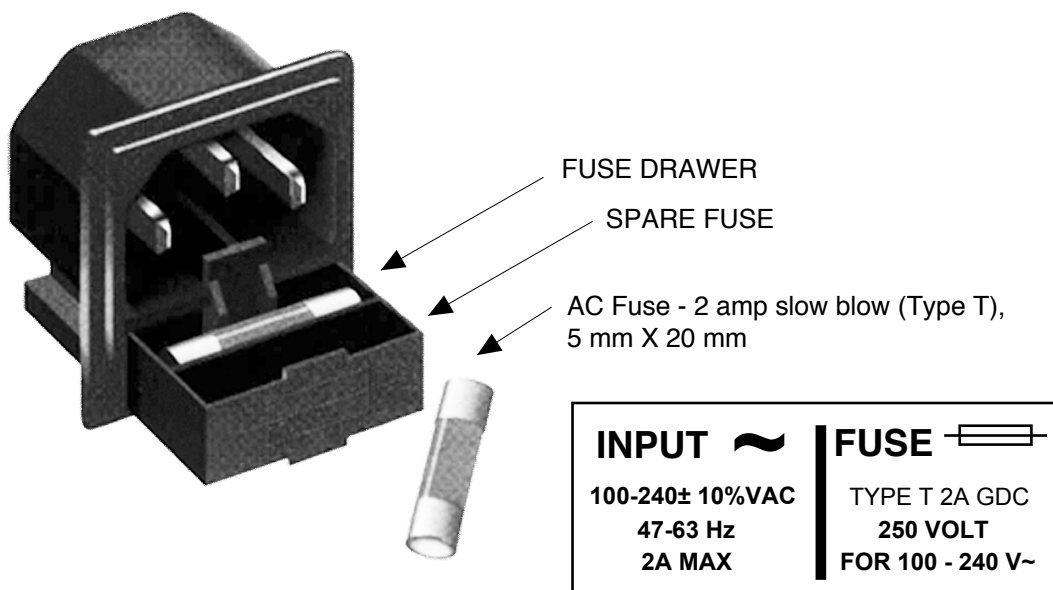

FIGURE 2.3 Fuse Location and Spare Fuse

2.5 Environmental Use Information

- A. Rack-Mounting** - To mount this equipment in a rack, please refer to the installation instructions located in the user manual furnished by the manufacturer of your equipment rack.
- B. Mechanical Loading** - Mounting of equipment in a rack should be such that a hazardous condition does not exist due to uneven weight distribution.
- C. Elevated Operating Ambient Temperature** - If installed in a closed or multi-unit rack assembly, the operating ambient temperature of the rack may be greater than room ambient temperature. Therefore, consideration should be given to Tmra (Maximum Recommended Ambient Temperature).
- D. Reduced Air Flow** - Installation of the equipment in a rack should be such that the amount of air flow required for safe operation of the equipment is not compromised. Additional space between units may be required.
- E. Circuit Overloading** - Consideration should be given to the connection of the equipment to the supply circuit and the effect that overloading of circuits could have on over current protection and supply wiring. Appropriate consideration of equipment name plate rating should be used, when addressing this concern.
- F. Reliable Earthing** - Reliable earthing of rack-mounted equipment should be maintained. Particular attention should be given to supply connections other than direct connection to the Branch (use of power strips).
- G. Top Cover** - There are no serviceable parts inside the product so, the Top Cover should not be removed. If the Top Cover is removed the ground strap and associated screw **MUST BE REINSTALLED** prior to Top Cover screw replacement. **FAILURE TO DO** this may cause **INGRESS** and/or **EGRESS** emission problems.



6170 Shiloh Road
Alpharetta, Georgia 30005

(770) 886-8005
FAX (770) 886-7964
Toll Free 888-900-5588

WEB www.crosstechnologies.com
E-MAIL info@crosstechnologies.com