

Instruction Manual

Model 2115-21-202 Block Upconverter

November 2013, Rev. 0

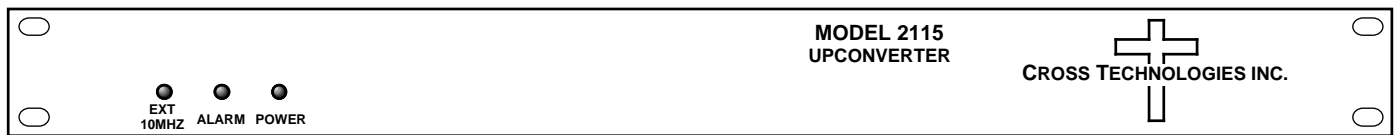

Data, drawings, and other material contained herein are proprietary to Cross Technologies, Inc., but may be reproduced or duplicated without the prior permission of Cross Technologies, Inc. for purposes of operating the equipment.

When ordering parts from Cross Technologies, Inc., be sure to include the equipment model number, equipment serial number, and a description of the part.



6170 Shiloh Road
Alpharetta, Georgia 30005

(770) 886-8005
FAX (770) 886-7964
Toll Free 888-900-5588

WEB www.crosstechnologies.com
E-MAIL info@crosstechnologies.com

INSTRUCTION MANUAL

MODEL 2115-21-202 Block Upconverter

<u>TABLE OF CONTENTS</u>	<u>PAGE</u>
Warranty	2
1.0 General	3
1.1 Equipment Description	3
1.2 Technical Characteristics	4
2.0 Installation	5
2.1 Mechanical	5
2.2 Rear Inputs and Outputs	6
2.3 Front Panel Indicators	6
2.4 Operation	7
3.0 Environmental Use Information	8

WARRANTY - The following warranty applies to all Cross Technologies, Inc. products.

All Cross Technologies, Inc. products are warranted against defective materials and workmanship for a period of one year after shipment to customer. Cross Technologies, Inc.'s obligation under this warranty is limited to repairing or, at Cross Technologies, Inc.'s option, replacing parts, subassemblies, or entire assemblies. Cross Technologies, Inc. shall not be liable for any special, indirect, or consequential damages. This warranty does not cover parts or equipment which have been subject to misuse, negligence, or accident by the customer during use. All shipping costs for warranty repairs will be prepaid by the customer. There are not other warranties, express or implied, except as stated herein.



6170 Shiloh Road
Alpharetta, Georgia 30005

(770) 886-8005
FAX (770) 886-7964
Toll Free 888-900-5588

WEB www.crosstechnologies.com
E-MAIL info@crosstechnologies.com

MODEL 2115-21-202 Block Upconverter

1.0 General

1.1 Equipment Description

The 2115-21-202 Block Upconverter converts two separate 950 - 1450 MHz signals to 18.3-18.8 GHz (LO=17.35 GHz) and to 19.7-20.2 GHz (LO=3.19 & 15.56 GHz). Front panel LEDs provide indication of DC power, external 10 MHz, and PLL alarm. Gain is 0 ± 3 dB. Connectors are SMA female for the RF and BNC female for the L-band and external reference input and reference output. A three-way switch controls which 10 MHz reference is being used. In the INT position, the internal reference is used, in the EXT position, the external reference is used, and in the AUTO position, the internal reference is used unless a +3 dBm \pm 3 dB, 10MHz signal is received on the external reference input. It is powered by a 100-240 \pm 10% VAC power supply, and in a 1 3/4" X 19" X 14" rack mount chassis.

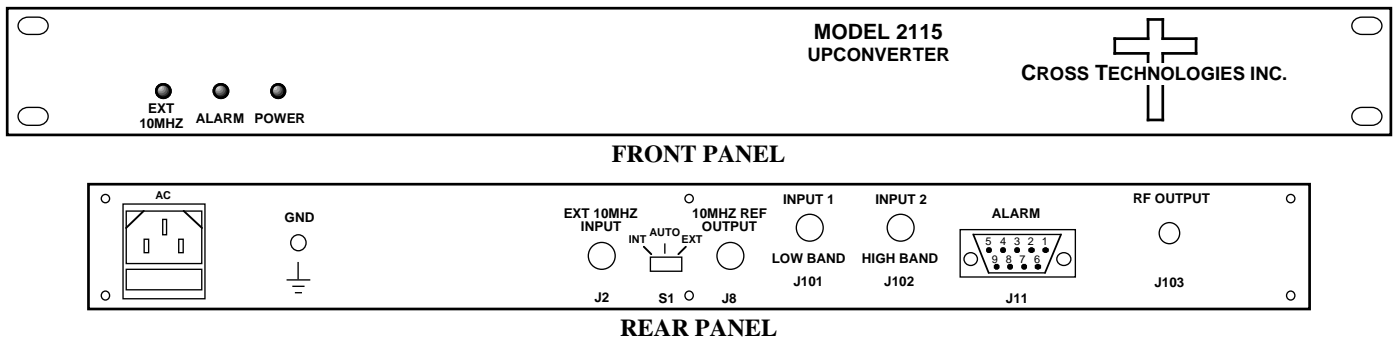

FIGURE 1.1 Front and Rear Panels

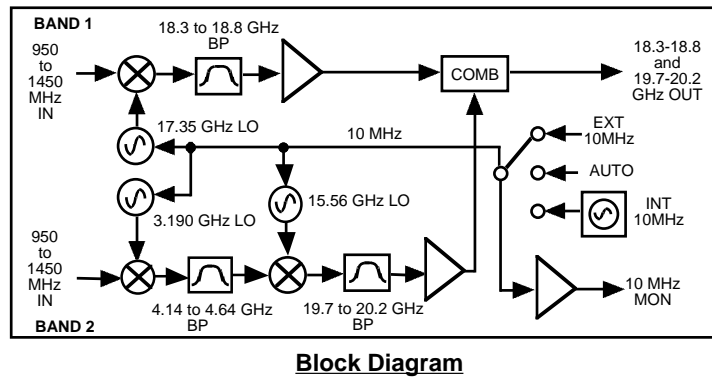

FIGURE 1.2 2115-21-202 Block Diagram

1.2 Technical Characteristics

TABLE 1.1 2115-21-202 Upconverter Specifications*

Input Characteristics					
Impedance / Return Loss	50Ω / 14 dB				
Frequency, Input 1, Input 2	950 to 1450 MHz (each input)				
Noise Figure, Maximum	20 dB Maximum Gain				
Input Level Range - Composite	-11 to -31 dBm				
Input Level Range - Carrier	-22 to -42 dBm				
Input 1 dB Compression	+4 dBm				
Output Characteristics					
Impedance / Return Loss	50Ω / 10 dB				
Frequency	18.3 - 18.8 and 19.7 - 20.2 GHz				
Output Level Range - Composite	-11 to -31 dBm				
Output Level Range - Carrier	-22 to -42 dBm				
Output 1 dB Compression	+4 dBm				
Channel Characteristics					
Gain	0 dB ±3 dB				
Image Rejection	> 50 dB, Minimum				
Spurious Inband	<-70 dBm				
Spurious, Out of band	<-60 dBm				
Intermodulation	<-50 dBC for two carriers each at -14 dBm out				
Frequency Response	±2 dB, 18.3 - 18.8 GHz and 19.7 - 20.2 GHz out; ±1 dB, 40 MHz BW				
Frequency Sense	Non-inverting				
LO Characteristics					
LO Frequency	17.35 GHz (Band 1) and 3.190 & 15.56 GHz (Band 2)				
Frequency Accuracy	±0.01 ppm maximum over temp internal reference; external reference input				
10 MHz In/Out Level	3 dBm ± 3 dB				
Phase Noise @ Frequency	100 MHz	1kHz	10kHz	100kHz	1MHz
	dBc/Hz	-55	-65	-80	-100
Controls, Indicators					
Power	Green LED				
PLL Alarm	Red LED, External Contact Closure				
Eternal 10 MHz	Yellow LED, Indicates ext. 10 MHz reference selected (rear panel DPDT switch)				
Other					
RF Connector	SMA (female). 50 Ω				
L-Band Connector	BNC (female). 50Ω				
10 MHz Connectors	BNC (female). 75Ω Connector: Works for 50Ω or 75Ω				
Alarm Connector	DB9 (female) - NO or NC contact closure on Alarm				
Size	19 inch, Standard Chassis, 1.75" high X 14.0" deep				
Power	100-240 ±10% VAC. 47-63 Hz. 45 watts maximum				
Available Options					
Standard -	50Ω SMA (RF), 50Ω BNC (L-Band)				
S7 -	50Ω SMA (RF), 75Ω BNC (L-Band)				
SF -	50Ω SMA (RF), 75Ω F-type (L-Band)				
SN -	50Ω SMA (RF), 50Ω N-type (L-Band)				
*+10°C to +40°C; Specifications subject to change without notice					

2.0 Installation

2.1 Mechanical - The 2115-21-202 consists of one RF PCB and a number of RF modules housed in a 1 RU (1 3/4 inch high) by 12 inch deep chassis. A switching, ± 12 , +24, +5 VDC power supply provides power for the assemblies. The 2115-21-202 can be secured to a rack using the 4 holes on the front panel.

Figure 2.0 shows how the 2115-21-202 is assembled.

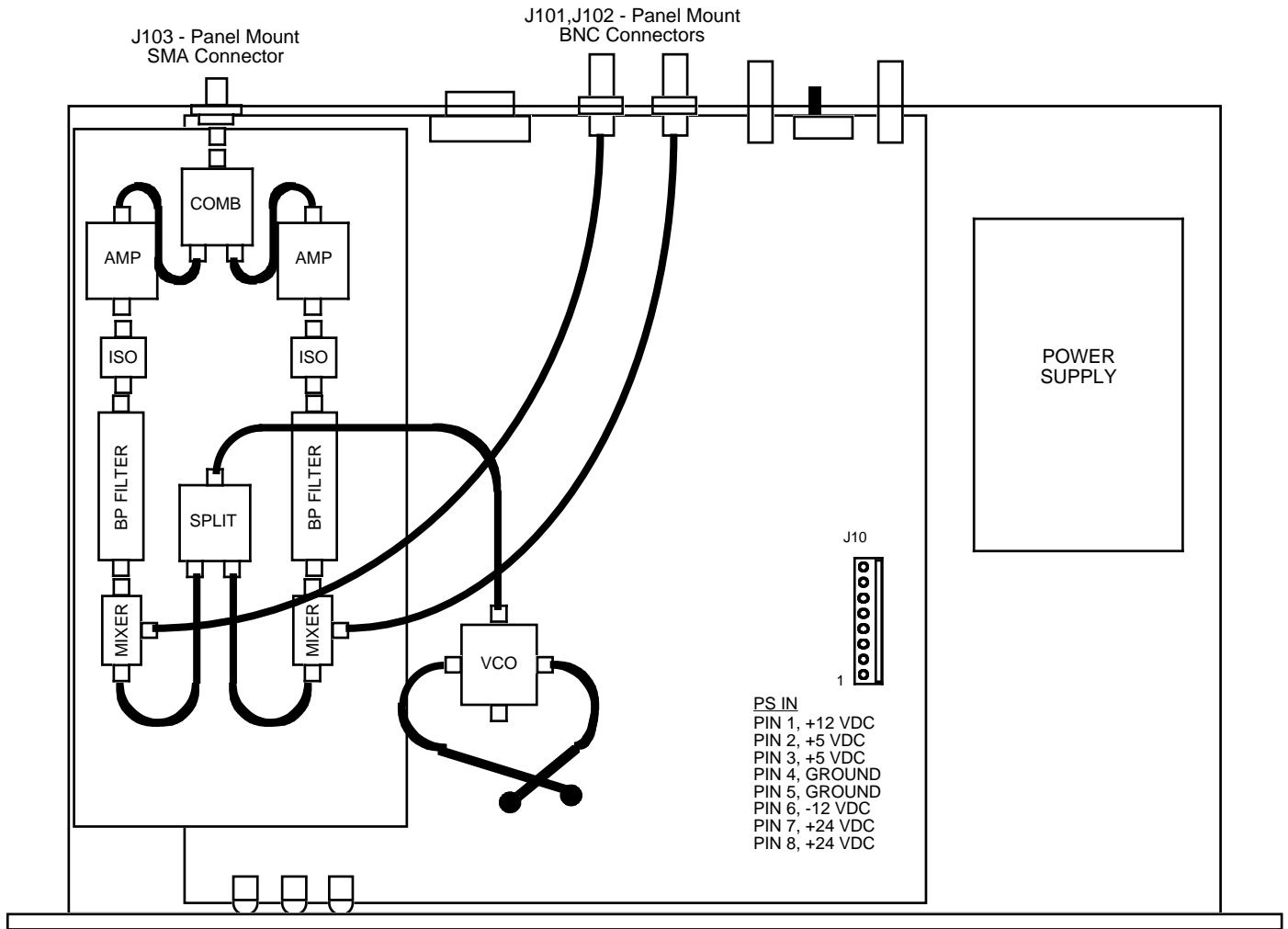

FIGURE 2.0 2115-21-202 Mechanical Assembly

2.2 Rear Panel Input/Output Signals

Figure 2.1 shows the input and output connectors on the rear panel.

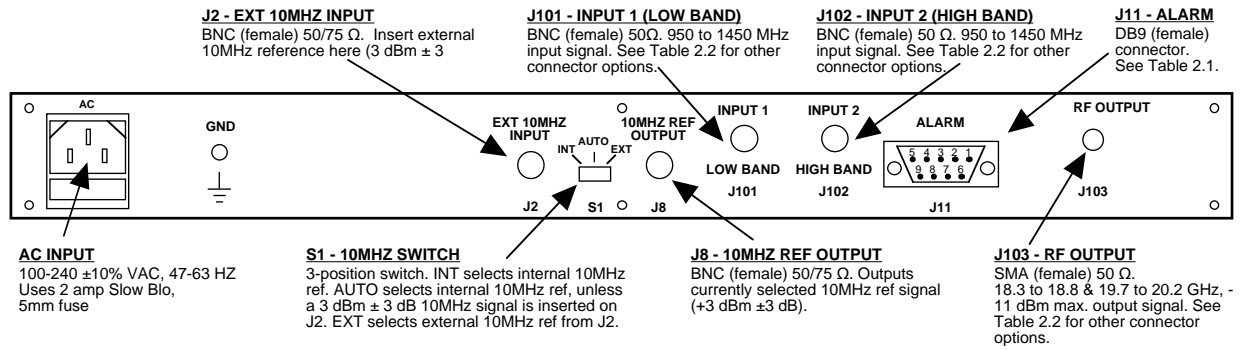

FIGURE 2.1 2115-21-202 Rear Panel I/O's

TABLE 2.1 J11 Pinouts (DB9)	
Pin	Function
1	Not Used
2	Not Used
3	Not Used
4	Not Used
5	GND
6	Alarm Relay: Common
7	Alarm Relay: Normally Open
8	Not Used
9	Alarm Relay: Normally Closed

TABLE 2.2 Connector Options		
Option	RF	L-Band
STD	SMA, 50Ω	BNC, 50Ω
S7	SMA, 50Ω	BNC, 75Ω
SF	SMA, 50Ω	Type F, 75Ω
SN	SMA, 50Ω	Type N, 50Ω

2.3 Front Panel Indicators

The following are the front panel indicators.

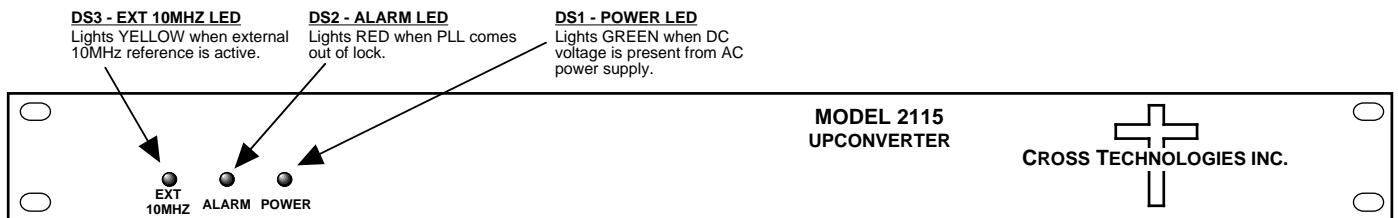

FIGURE 2.2 2115-21-202 Front Panel Controls and Indicators

2.4 Installation / Operation

2.4.1 Installing and Operating the 2115-21-202 Upconverter

1. Connect a -11 dBm maximum composite signal (950 - 1450 MHz) to INPUT 1, J101 (Figure 2.1).
2. Connect a -11 dBm maximum composite signal (950 - 1450 MHz) to INPUT 2, J102 (Figure 2.1).
3. Connect the RF OUTPUT, J103, to the external equipment.
4. Connect 100-240 \pm 10% VAC, 47 - 63 Hz to AC connector on the back panel.
5. Be sure DS1 (green, DC Power) is on and DS2 (red, Alarm) is off (Figure 2.2).
6. Select either INT (for internal 10MHz ref), AUTO (for internal 10MHz ref UNLESS a external 10MHz, 3 dBm signal is connected to J2), or EXT (for external 10MHz, 3 dBm ref that is inserted at J2) on rear panel switch, S1 (Figure 2.1).
7. If EXT is selected or AUTO is selected and there is a 10MHz, 3 dBm signal at J2, check that DS3 (yellow, Ext 10MHZ) is on (Figure 2.2).
8. Check that a 10MHz, 3 dBm \pm 3 dB signal is present at the 10MHz REF OUTPUT, J8 (Figure 2.1).
9. AC Fuse - The fuse is a 5 mm X 20 mm, 2 amp slow blow (Type T) and is inserted in the far slot in the drawer below the AC input as shown in Figure 2.3. There is a spare fuse in the near slot. If a fuse continues to open, the power supply is most likely defective.

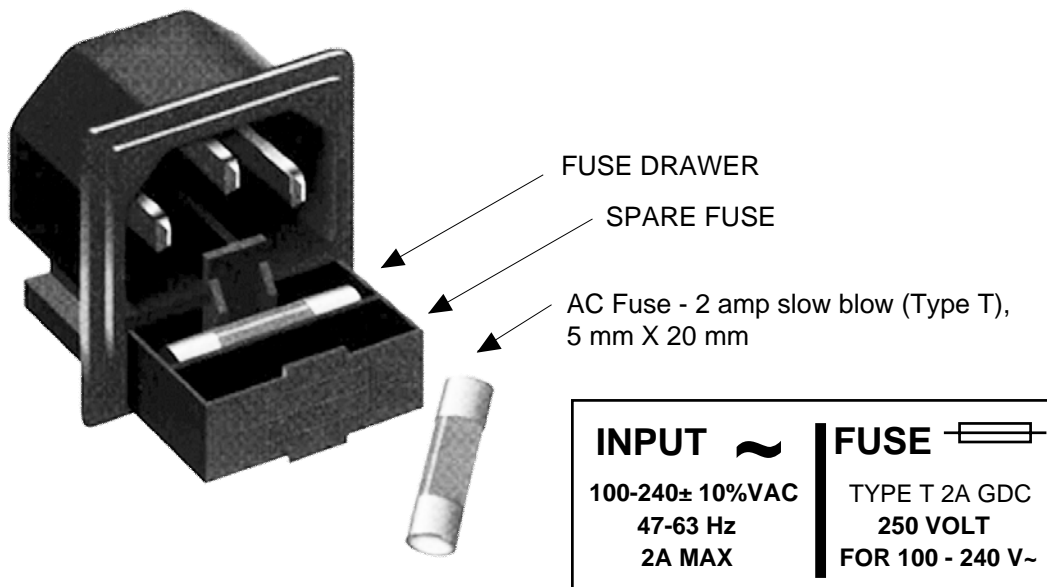

FIGURE 2.3 Fuse Location and Spare Fuse

3.0 Environmental Use Information

- A. **Rack-Mounting** - To mount this equipment in a rack, please refer to the installation instructions located in the user manual furnished by the manufacturer of your equipment rack.
- B. **Mechanical Loading** - Mounting of equipment in a rack should be such that a hazardous condition does not exist due to uneven weight distribution.
- C. **Elevated Operating Ambient Temperature** - If installed in a closed or multi-unit rack assembly, the operating ambient temperature of the rack may be greater than room ambient temperature. Therefore, consideration should be given to Tmra.
- D. **Reduced Air Flow** - Installation of the equipment in a rack should be such that the amount of air flow required for safe operation of the equipment is not compromised. Additional space between units may be required.
- E. **Circuit Overloading** - Consideration should be given to the connection of the equipment to the supply circuit and the effect that overloading of circuits could have on over current protection and supply wiring. Appropriate consideration of equipment name plate rating should be used, when addressing this concern.
- F. **Reliable Earthing** - Reliable earthing of rack-mounted equipment should be maintained. Particular attention should be given to supply connections other than direct connection to the Branch (use of power strips).
- G. **Top Cover** - There are no serviceable parts inside the product so, the Top Cover should not be removed. If the Top Cover is removed the ground strap and associated screw **MUST BE REINSTALLED** prior to Top Cover screw replacement. **FAILURE TO DO** this may cause **INGRESS** and/or **EGRESS** emission problems.



6170 Shiloh Road
Alpharetta, Georgia 30005

(770) 886-8005
FAX (770) 886-7964
Toll Free 888-900-5588

WEB www.crosstechnologies.com
E-MAIL info@crosstechnologies.com

Printed in USA