

# Instruction Manual

# Model 2083-2713 Block Translator

July 2018, Rev. 0

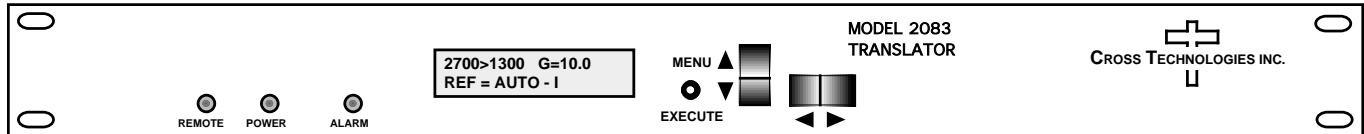

Data, drawings, and other material contained herein are proprietary to Cross Technologies, Inc., but may be reproduced or duplicated without the prior permission of Cross Technologies, Inc. for purposes of operating the equipment.

When ordering parts from Cross Technologies, Inc., be sure to include the equipment model number, equipment serial number, and a description of the part.



6170 Shiloh Road  
Alpharetta, Georgia 30005

(770) 886-8005  
FAX (770) 886-7964  
Toll Free 888-900-5588

WEB [www.crosstechnologies.com](http://www.crosstechnologies.com)  
E-MAIL [info@crosstechnologies.com](mailto:info@crosstechnologies.com)

# INSTRUCTION MANUAL

## MODEL 2083-2713 Block Translator

<u>TABLE OF CONTENTS</u>	<u>PAGE</u>
<b>Warranty</b>	<b>2</b>
<b>1.0 General</b>	<b>3</b>
1.1 Equipment Description	<b>3</b>
1.2 Technical Characteristics	<b>4</b>
1.3 Monitor & Control Interface	<b>6</b>
<b>2.0 Installation</b>	<b>11</b>
2.1 Mechanical	<b>12</b>
2.2 Rear I/O's	<b>12</b>
2.3 Front Panel Controls, Indicators	<b>13</b>
2.4 Operation	<b>14</b>
2.5 Menu Settings	<b>15</b>
<b>3.0 Environmental Use Information</b>	<b>20</b>

**WARRANTY** - The following warranty applies to all Cross Technologies, Inc. products.

All Cross Technologies, Inc. products are warranted against defective materials and workmanship for a period of one year after shipment to customer. Cross Technologies, Inc.'s obligation under this warranty is limited to repairing or, at Cross Technologies, Inc.'s option, replacing parts, subassemblies, or entire assemblies. Cross Technologies, Inc. shall not be liable for any special, indirect, or consequential damages. This warranty does not cover parts or equipment which have been subject to misuse, negligence, or accident by the customer during use. All shipping costs for warranty repairs will be prepaid by the customer. There are not other warranties, express or implied, except as stated herein.



6170 Shiloh Road  
Alpharetta, Georgia 30005

(770) 886-8005  
FAX (770) 886-7964  
Toll Free 888-900-5588

WEB [www.crosstechnologies.com](http://www.crosstechnologies.com)  
E-MAIL [info@crosstechnologies.com](mailto:info@crosstechnologies.com)

# MODEL 2083-2713 Block Translator

## 1.0 General

### 1.1 Equipment Description

**2083-2713 Block Translator** - The 2083-2713 Block Translator converts a 2550-2750 MHz block to 1200-1400 MHz block with or without spectrum inversion (selectable), low group delay and flat frequency response. The 2550-2750 MHz input is mixed with synthesized local oscillator (LO) signals, first to a 400 MHz center frequency and finally to the 1200-1400 MHz block output. The gain can be set for 0 to -30 dB in  $0.5 \pm 0.5$  dB increments. The output translation is fixed. Multifunction switches select Gain and internal or External 10 MHz reference which appear on the LCD display and can be adjusted remotely. Front panel LEDs provide indication of DC power (green), PLL alarm (red), and remote operation (yellow). Connectors are BNC female for RF and 10 MHz input and output. It is powered by a 100-240  $\pm 10\%$  VAC, 47-63 HZ input power supply and housed in a 1 3/4" X 19" X 16" rack mount chassis.

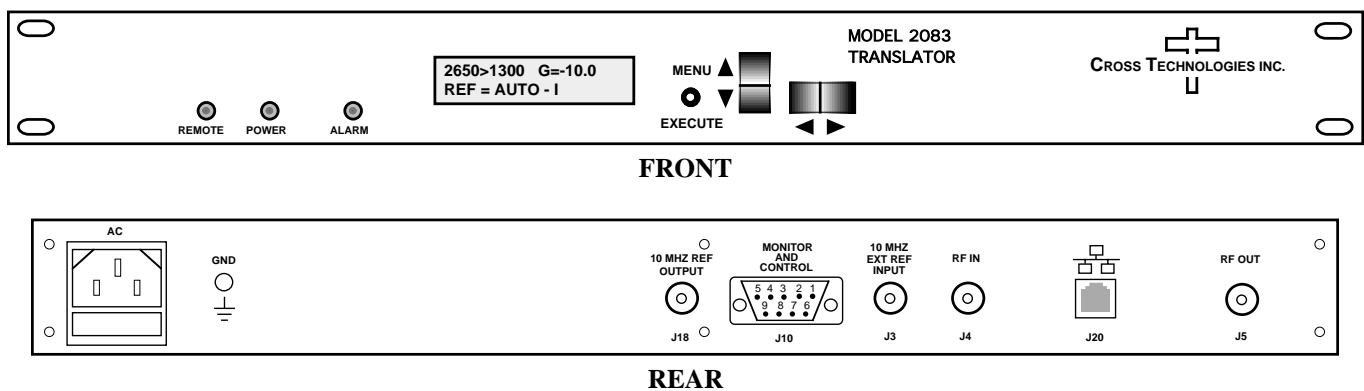

**FIGURE 1.1 Model 2083-2713 Front and Rear Panels**

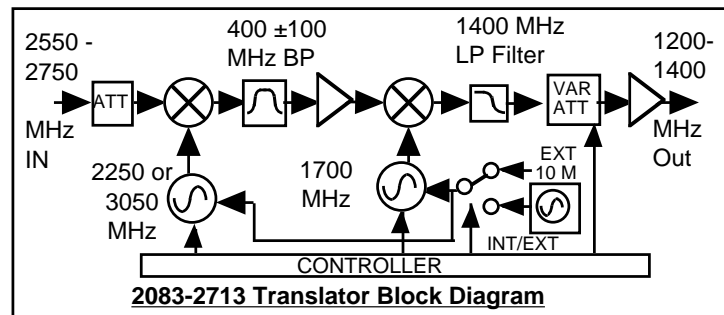

**FIGURE 1.2 Model 2083-2713 Translator Block Diagram**

## 1.2 Technical Characteristics

<b>TABLE 1.0 2083-2713 Block Translator Specifications**</b>					
<b>Input Characteristics</b>					
Input Impedance/RL	50Ω/14 dB				
Frequency	2550 - 2750 MHz				
Input Composite Level	-15 to 0 dBm				
<b>Output Characteristics</b>					
Impedance/RL	50Ω / 14 dB				
Frequency	1200 - 1400 MHz				
Output Level	-30 to -15 dBm				
Output 1 dB Compression	-5 dBm, at maximum gain				
<b>Channel Characteristics</b>					
Gain, Maximum; adjustment	+0 dB ±1 dB, max. gain; 0 to -30 dB gain adjustment in 0.5 ± 0.5 dB Steps				
Spurious, Inband	< -55 dBC in band, signal dependent and signal independent; -15 dBm Out				
Spurious, Out of Band	< -50 dBm, 0.75-1.19 GHz and 1.41-1.69 GHz Out				
Intermodulation	<-55 dBC for two carriers each at -20 dBm out				
Frequency Response	± 2.0 dB, 200 MHz bandwidth; ± 1.0 dB, any 100 MHz bandwidth; ± 0.5 dB, any 20 MHz increment				
Frequency Sense	Non-inverting or Inverting, selectable				
<b>Synthesizer Characteristics</b>					
Translation; Accuracy	± 1 ppm; Option H, ±0.01 ppm				
Reference	10 MHz Internal; Internal / External Selection				
Phase Noise @ Frequency	100 MHz	1kHz	10kHz	100kHz	1MHz
dBC/Hz	-70	-80	-80	-95	-100
<b>Controls, Indicators</b>					
Gain (MGC)	Direct readout LCD; manual or remote selection				
External Ref. (Option -E)	Direct readout LCD; manual or remote selection				
Power, Alarm; Remote	Green LED; Red LED; Yellow LED				
Remote	RS232C/RS485/422, 9600 baud (Ethernet Optional)				
<b>Other</b>					
RF In/RF Out Connector	BNC (female)				
10 MHz Connector	BNC (female), 75Ω, works with 50 or 75 ohms				
Alarm/Remote Connector	DB9 (female); No or NC contact closure on Alarm				
Size	19 inch Standard Chassis 1.75" high x 16.0" deep				
Power	100-240 (±10%) VAC, 47- 63 Hz, 30 watts maximum				
<b>Available Options (see page 5...)</b>					
**+10°C to +40°C; Specifications subject to change without notice.					<b>Cross Technologies, Inc. 2018</b>

## 1.2 Technical Characteristics, continued...

<b>Available Options (2083-2713 Block Translator)</b>	
W101 -	Low Deviation Modulation Input
H -	High Stability ( $\pm 0.01$ ) Internal Reference
<b>Communication Interface / Standard RS232</b>	
W8 -	Ethernet; with Web Browser
W18 -	Ethernet; with Web Browser & SNMP
W28 -	Ethernet; with TCP/IP, Telnet®
<b>Connector /Impedance</b>	
Std. -	50 $\Omega$ BNC (RF IN), 50 $\Omega$ BNC (RF OUT)
NN -	50 $\Omega$ N (RF In), 50 $\Omega$ N (RF Out)
SS -	50 $\Omega$ SMA (RF IN), 50 $\Omega$ SMA (RF OUT)
Contact Cross Technologies for other options.	

### 1.3 Monitor and Control Interface

#### A) Remote Serial Interface

**Protocol:** RS-232C, 9600 baud rate, no parity, 8 data bits, 1 start bit, and 1 stop bit.  
(RS-232C, RS-422, or **RS-485 - option -Q**)

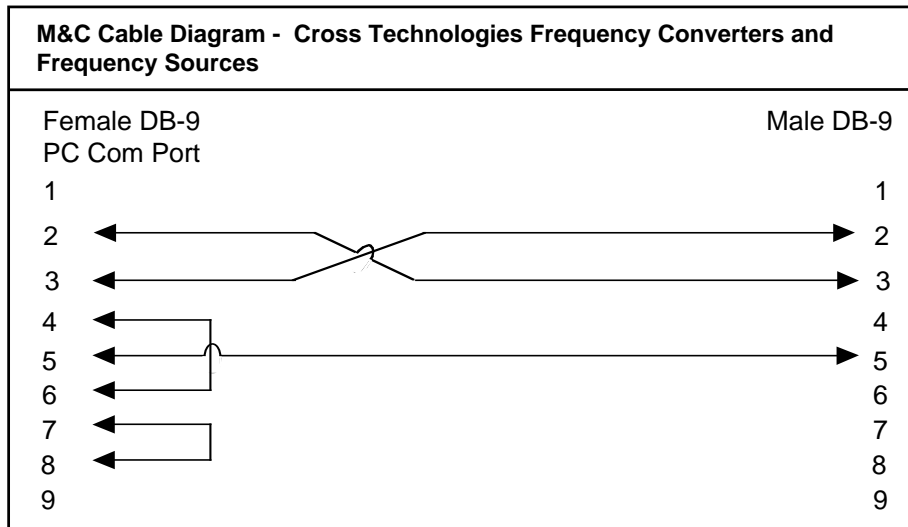

**Connector:** Rear panel, DB-9 male

J10 Pinouts (RS-232C/422/485)	
Pin	Function
1	Rx-
2	Rx+ (RS-232C)
3	Tx+ (RS-232C)
4	Tx-
5	GND
6	Alarm Relay: Common
7	Alarm Relay: Normally Open
8	Not Used
9	Alarm Relay: Normally Closed

**B) Commands** - Table 1.0 lists the commands for the 2083-2713 and briefly describes them. After a command is sent the 2083-2713 sends a return “>” indicating the command has been received and executed.

**General Command Format** - The general command format is {aaCND...}, where:

{ = start byte

aa = address (**RS-485 only - option -Q**)

C = 1 character, either C (command) or S (status)

N = 1 character command or status request

D = 1 character or more of data (depends on command)

} = stop byte

\* PLEASE NOTE: The two character {aa}(00-31) prefix, in the table below, should be used ONLY when RS-485, (OPTION-Q), is selected.

Table 1.0 M&C Commands for Models 2083-2713		
Function	Format	Description
Set Gain	{aaCGxxxx}	where: aa = unit address, range = 00 to 31, only used if interface is RS485, otherwise omit. I = command code xxxx = gain in 0.5 dB steps, omit the decimal point Range: = -300 to 0 in 0.5 dB steps example: {CG-155} Will set the unit's gain to -15.5 dB. Note: The negative sign is assumed if not included, i.e. {CG155} is parsed the same as {CG-155}. The unit will reply with the '>' character if the command is successfully processed.
Set Spectrum Invert	{aaCIx}	where: aa = unit address, range = 00 to 31, only used if interface is RS485, otherwise omit I = command code x = 0 to set to internal reference, x = 1 to set to external reference, x = 2 to set to auto reference example: {CI1} Will set the reference mode to Auto. The unit will reply with the '>' character if the command is successfully processed.
Set Reference Mode	{aaCEx}	where: aa = unit address, range = 00 to 31, only used if interface is RS485, otherwise omit E = command code x = 0 to set to internal reference, x = 1 to set to external reference, x = 2 to set to auto reference example: {CE2} Will set the reference mode to Auto. The unit will reply with the '>' character if the command is successfully processed.

Continued from page 8...

TABLE 1.0 2083-2713 M&C Commands, Continued		
Function	Format	Description
Set Remote Off	{aaCRO}	where: aa = unit address, range = 00 to 31, only used if interface is RS485, otherwise omit R = command code O, ascii number zero. example: {CRO} Will disable the unit's serial M&C port. The unit will reply with the '>' character if the command is successfully processed. (Note: this command only affects the serial M&C port, the ethernet port is always on and will not be affected)
Set Remote On	#	Just the ascii pound sign, (0x23) Will enable the unit's serial M&C port. The unit will reply with the '>' character if the command is successfully processed. (Note: this command only affects the serial M&C port, the ethernet port is always on and will not be affected)



### C) Status Requests/Inquiries -

Table 2.0 lists the status requests for the 2083-2713 and briefly describes them.

\* PLEASE NOTE: The two character {aa}(00-31) prefix, in the table below, should be used ONLY when RS-485, (OPTION-Q), is selected.

Table 2.0 Status Request/Inquiries for Models 2083-2713		
	Function	Format
Gain Inquiry	{aaSG}	returns: {aaSGxxxx}
		where:
		aa = unit address, range = 00 to 31, only used if interface is RS485, otherwise omit
		G = command code
		xxxx = gain in dB (decimal point omitted)
		The unit will append the '>' character if the command is successfully processed.
Spectrum Invert Inquiry	{aaSI}	returns: {aaSIxxxx}
		where:
		aa = unit address, range = 00 to 31, only used if interface is RS485, otherwise omit
		I = command code
		x = 0 if spectrum is normal (non-inverted),
		x = 1 if spectrum is inverted
		The unit will append the '>' character if the command is successfully processed.
Reference Mode Inquiry	{aaSE}	returns: {aaSEx}
		where:
		aa = unit address, range = 00 to 31, only used if interface is RS485, otherwise omit
		E = command code
		x = 0 if reference mode is internal, x = 1 if external,
		x = 2 if auto
		The unit will append the '>' character if the command is successfully processed.

Continued on page 10...

Continued from page 9...

Table 2.0 Status Request/Inquiries for Models 2083-2713, Continued...		
Function	Format	Description
Reference Status Inquiry	{aaSB}	returns: {aaSBx} where: aa = unit address, range = 00 to 31, only used if interface is RS485, otherwise omit. B = command code x = 1 if the unit is using the external reference, x = 0 if the unit is using the internal reference note: this inquiry is useful if the reference mode is auto and the user wants to know if the unit has switched to the internal reference. The unit will append the '>' character if the command is successfully processed.
Alarm Inquiry	{aaSA}	returns: {aaSAx} where: aa = unit address, range = 00 to 31, only used if interface is RS485, otherwise omit. A = command code x = 0 if alarm is off, x = 1 if alarm is on. The unit will append the '>' character if the command is successfully processed.
Product/Model Info Inquiry	{aaSV}	returns {aaSV2083-xxxx yyyy ver5.xx} where 2083-xxxx = product model yyyy = list of options, if any "ver" = separates model & options from firmware version 5.xx = firmware version

## 2.0 Installation

**2.1 Mechanical** - The 2083-2713 consists of one RF/Controller PCB housed in a 1 RU (1 3/4 inch high) by 16 inch deep chassis. A switching,  $\pm 12$ , +24, +5 VDC power supply provides power for the assemblies. The 2083-2713 can be secured to a rack using the 4 holes on the front panel. Figure 2.1 shows how the 2083-2713 is assembled.

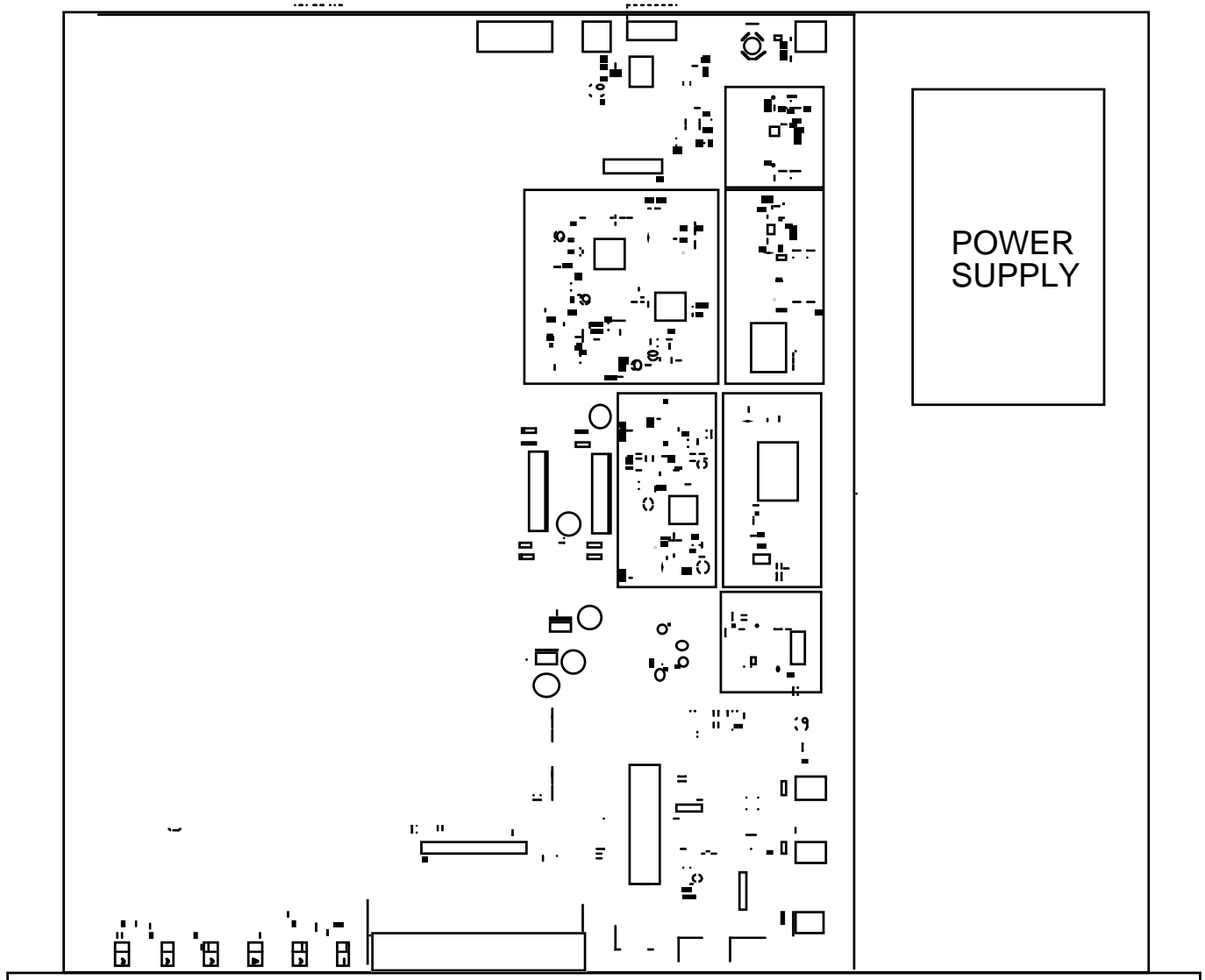

**FIGURE 2.1 2083-2713 Mechanical Assembly**

## 2.2 Rear Panel Input/Output Signals - Figure 2.2 shows the input and output connectors on the rear panel.

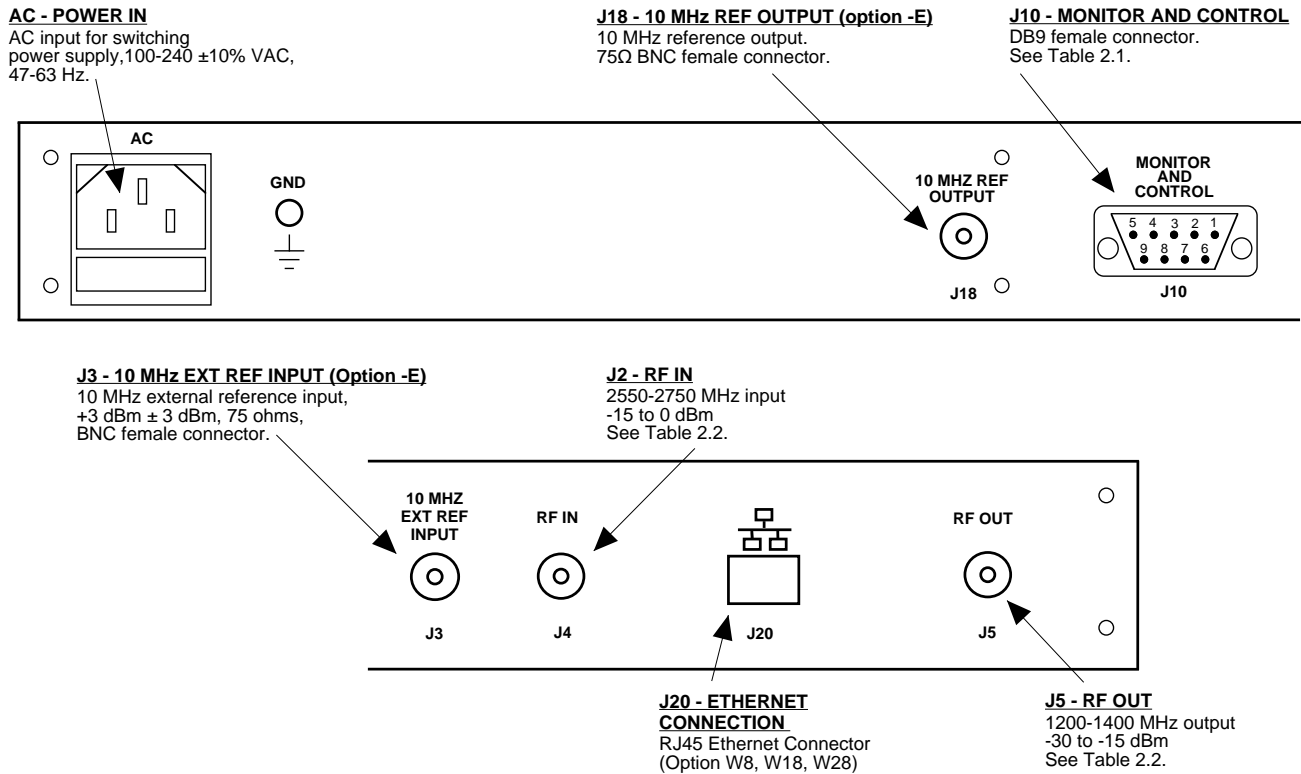

**FIGURE 2.2 2083-2713 Rear Panel I/Os**

TABLE 2.1 J10 Pinouts (RS-232C*)	
Pin	Function
1	Not Used
2	Rx+ (RS-232C)
3	Tx+ (RS-232C)
4	Not Used
5	GND
6	Alarm Relay: Common
7	Alarm Relay: Normally Closed
8	Not Used
9	Alarm Relay: Normally Open

### \*Remote Serial Interface

Interface: DB-9 Male

Protocol: RS-232C, 9600 baud rate, no parity, 8 data bits, 1 start bit, 1 stop bit

TABLE 2.2 Connector/Impedance Options		
Option	RF Out	RF In
STD	50 $\Omega$ BNC	50 $\Omega$ BNC
-NN	50 $\Omega$ N	50 $\Omega$ N
-SS	50 $\Omega$ SMA	50 $\Omega$ SMA

**2.3 Front Panel Controls and Indicators -** The following are the front panel controls and indicators.

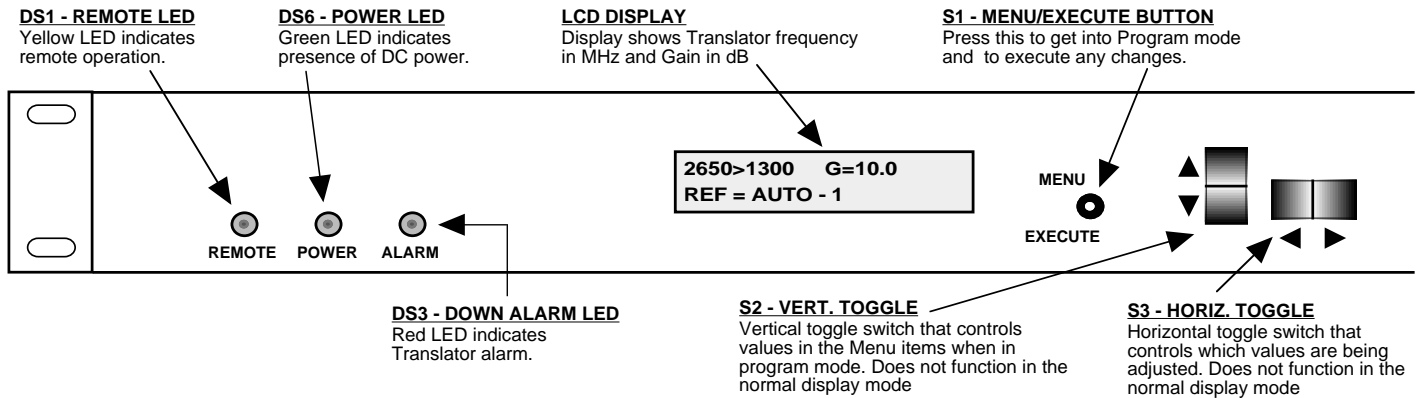
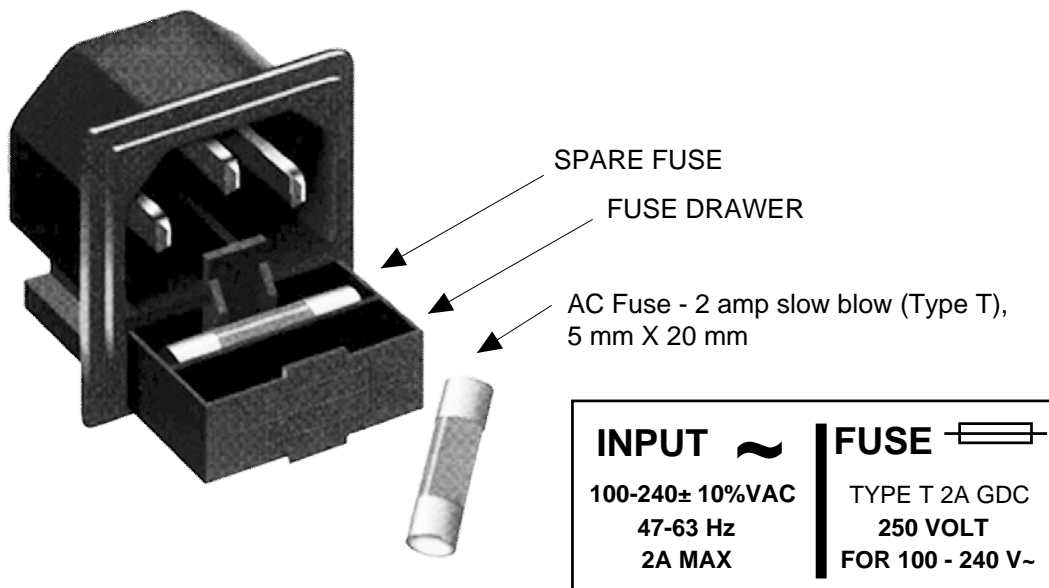

**FIGURE 2.3 2083-2713 Front Panel Controls and Indicators**

## 2.4 Operation

### 2.4.1 Installing and Operating the 2083-2713 Block Translator

1. Connect a -15 dBm to 0 dBm signal to RF IN, J2 (Figure 2.2)
2. Connect the RF OUT, J5, to the external equipment
3. Connect 100-240  $\pm$ 10% VAC, 47 - 63 Hz to AC on the back panel.
4. Set the gain for 0 to -30 dBm (See Section 2.5 Menu Settings).
5. Be sure DS6 (green, DC Power) is on and DS (red, Alarm) is off (Figure 2.3).
6. AC Fuse - The fuse is a 5 mm X 20 mm, 2 amp slow blow (Type T) and is inserted in the far slot in the drawer below the AC input as shown in Figure 2.4. There is a spare fuse in the near slot.  
If a fuse continues to open, the power supply is most likely defective.



**FIGURE 2.4 Fuse Location and Spare Fuse**

## 2.5 Menu Settings

**2.5.1 Functions** - This section describes operation of the front panel controls. There are three operator switches, the LCD display and alarm indicator LEDs. All functions for the equipment are controlled by these components. The functions are (see Figure 2.5):

### **Power Up**

### **Normal Display**

- Menu 1** Gain (0 to -30, 1 dB Steps)
- Menu 2** Set Unit to Remote Operation
- Menu 3** Set Interface
- Menu 4** Set RS-485 address
- Menu 5** Select External 10 MHz

**Save Menu** When go to “R” or at end

Alarm indications appear on the LEDs (See figure 2.3).

All program changes must start with the operation of the Menu/Execute switch and must also end with the operation of the Menu/Execute switch verified by the “Save Settings?” Menu. If this sequence is not followed, none of the changes will take effect. If programming is initiated and no operator action takes place for approximately 30 seconds (before the final press of the Menu/Execute switch) the display will revert to its previous status and you will need to start over.

## 2.5.2 Power On Settings

**NOTE: THE LAST STATUS OF A UNIT IS RETAINED EVEN WHEN POWER IS REMOVED. WHEN POWER IS RESTORED, THE UNIT WILL RETURN TO IT'S PREVIOUS SETTINGS.**

When power is first applied, the LCD display goes through three steps.

1. The LCD goes black to show all segments are functioning.
2. The software version will be displayed.



REV 1.00

3. The present frequency and gain of the down converter is shown.

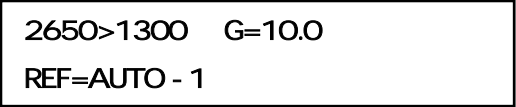

2650>1300 G=10.0  
REF=AUTO - 1

The unit is now operational and ready for any changes the operator may desire.

## 2.5.3 Control Switches

1. Menu/Execute - Any change to the programming of the unit must be initiated by pressing the Menu/Execute switch and completed by pressing the Menu/Execute switch.
2. Horizontal Switch - This switch is mounted so its movement is horizontal and moves the cursor left or right.
3. Vertical Switch - This switch is mounted so its movement is vertical and has two functions:
  - a. During frequency, gain changes, the vertical movement will raise or lower the number in the direction of the arrows.
  - b. For other functions such Mute on/off, the vertical switch will alternately turn the function on or off regardless of the direction operated.



### 2.5.3 Gain Changes

When you get to this menu note that the gain changes will be made as you make them but if you do not wish to save the changes you have made, scroll to “**R**” and push the Menu/Execute switch and select “**NO**” in the “**SAVE SETTINGS?**” window or **do not press the Menu/Execute switch**; simply do nothing for approximately 12 seconds, and the system will return to the normal operating mode.

To change the DOWNCONVERTER GAIN:

Push the Menu/Execute switch to get to the gain setting  
(See Figure 2.5 for the sequence of menu options):

G = -20	R
---------	---

Pressing the Up/Down switch will change the gain in 1 or 10 dB steps depending on the cursor location:

G = -15	R
---------	---

By using the horizontal rocker switch the cursor can be moved left or right. Pressing the Up/Down switch will toggle the display digit selected until you have the desired gain.

G = -1 <u>5</u>	R
-----------------	---

**NOTE: THE GAIN WILL BE CHANGED AS YOU ADJUST THE NUMBERS. HOWEVER, THE VALUE WILL NOT BE STORED UNTIL YOU INDICATE YES IN THE SAVE SETTINGS WINDOW.**

When the display indicates the value desired you can push the Menu/Execute switch to get to the next item OR you can scroll to “**R**” and push the Menu/Execute switch to get to:

SAVE SETTINGS? <u>Y</u> N
---------------------------

Selecting **Y** will save the new settings. Selecting **N** will revert to the previous settings.

Pushing the Menu/Execute switch then takes you to this:

2650>1300    G=10.0
REF=AUTO - 1

Figure 2.5 gives the menu items and how to make changes.

## 2.5.5 Alarm Indications

An alarm condition will occur if any local oscillator phase lock loop (PLL) comes out of lock. The Mute LED will light if you select Mute and the Remote LED will light when you select the Remote mode.

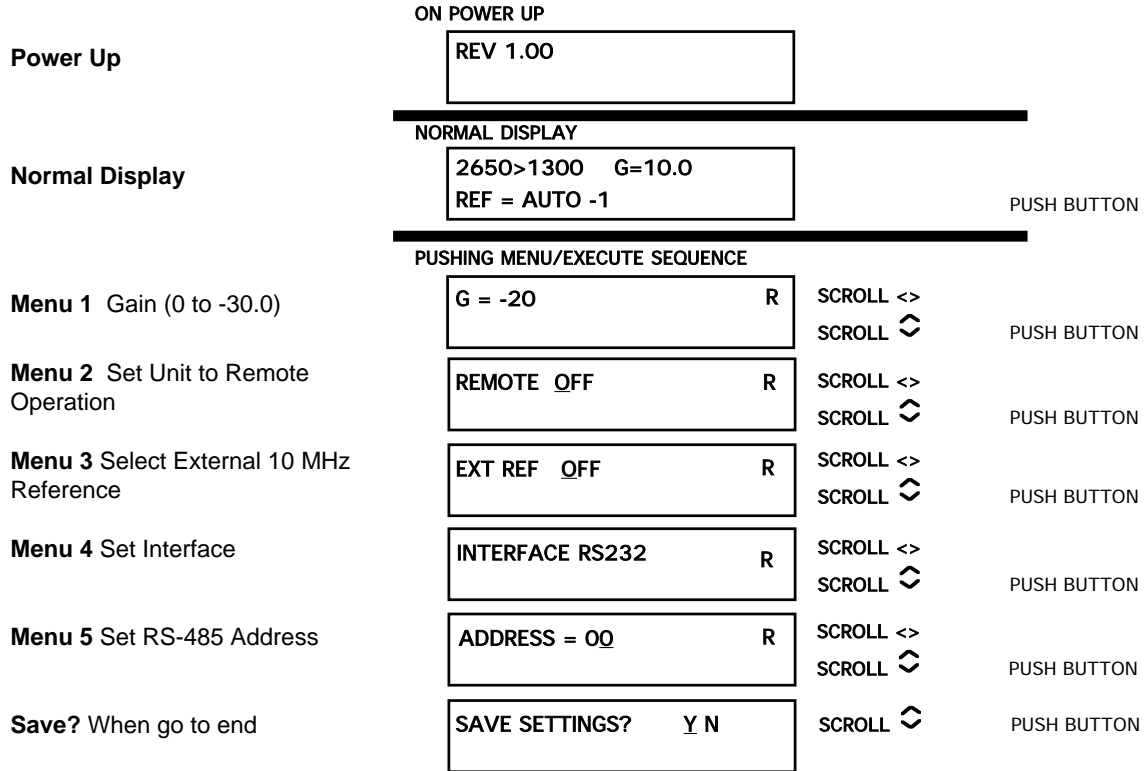

**FIGURE 2.5 Menu Display and Sequence**

## 2.5.6 Alarm Indications

An alarm condition will occur if any local oscillator phase lock loop (PLL) comes out of lock. The Remote LED will light when you select the Remote mode.

### 2.5.6 10 MHz Reference Mode Operation

**Internal Mode:** The unit uses its own built-in 10 MHz OCXO. The Internal Reference is present on the Reference Output Connector, J18. REF = INT appears on the front panel display.

**External Mode:** The unit uses a 10 MHz Reference that is connected to the External Reference Input, J3. REF = EXT appears on the front panel display. The External 10 MHz Reference level must be +3dBm,  $\pm 3$ dB. If the External 10 MHz signal does not meet the unit's specified parameters then the unit will not function properly. The External Reference is present on the Reference Output connector, J18.

**Auto Mode:** The unit defaults to the External 10 MHz Reference as long as the level meets the +3dBm,  $\pm 3$ dB specification. REF = AUTO - E appears on the front panel display where the -E indicates that the unit is using the External 10 MHz Reference. The External Reference is present on the Reference Output connector, J18.

If the external 10 MHz Reference signal level is less than -1dBm, the unit switches to Internal 10 MHz Reference. REF = AUTO -I appears on the front panel display where -I indicates that the unit is using the Internal 10 MHz Reference. The Internal 10 MHz Reference is present on the reference output connector, J18.

### 3.0 Environmental Use Information

- A. **Rack-Mounting** - To mount this equipment in a rack, please refer to the installation instructions located in the user manual furnished by the manufacturer of your equipment rack.
- B. **Mechanical Loading** - Mounting of equipment in a rack should be such that a hazardous condition does not exist due to uneven weight distribution.
- C. **Elevated Operating Ambient Temperature** - If installed in a closed or multi-unit rack assembly, the operating ambient temperature of the rack may be greater than room ambient temperature. Therefore, consideration should be given to Tmra (Maximum Recommended Ambient Temperature).
- D. **Reduced Air Flow** - Installation of the equipment in a rack should be such that the amount of air flow required for safe operation of the equipment is not compromised. Additional space between units may be required.
- E. **Circuit Overloading** - Consideration should be given to the connection of the equipment to the supply circuit and the effect that overloading of circuits could have on over current protection and supply wiring. Appropriate consideration of equipment name plate rating should be used when addressing this concern.
- F. **Reliable Earthing** - Reliable earthing of rack-mounted equipment should be maintained. Particular attention should be given to supply connections other than direct connection to the Branch (use of power strips).
- G. **Top Cover** - There are no serviceable parts inside the product so, the Top Cover should not be removed. If the Top Cover is removed the ground strap and associated screw **MUST BE REINSTALLED** prior to Top Cover screw replacement. **FAILURE TO DO** this may cause **INGRESS** and/or **EGRESS** emission problems.



6170 Shiloh Road  
Alpharetta, Georgia 30005

(770) 886-8005  
FAX (770) 886-7964  
Toll Free 888-900-5588

WEB [www.crosstechnologies.com](http://www.crosstechnologies.com)  
E-MAIL [info@crosstechnologies.com](mailto:info@crosstechnologies.com)

Printed in USA