

Instruction Manual

Model 2083-218# Block Translator

April 2014, Rev. 0

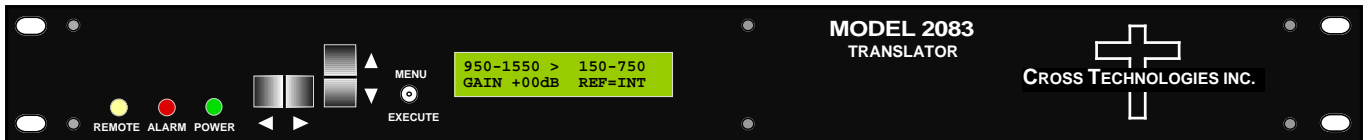

Data, drawings, and other material contained herein are proprietary to Cross Technologies, Inc., but may be reproduced or duplicated without the prior permission of Cross Technologies, Inc. for purposes of operating the equipment. Printed in USA.

When ordering parts from Cross Technologies, Inc., be sure to include the equipment model number, equipment serial number, and a description of the part.

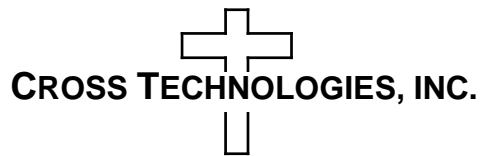

6170 Shiloh Road
Alpharetta, Georgia 30005

(770) 886-8005
FAX (770) 886-7964
Toll Free 888-900-5588

WEB www.crosstechnologies.com
E-MAIL info@crosstechnologies.com

INSTRUCTION MANUAL

MODEL 2083-218# Block Translator

| <u>TABLE OF CONTENTS</u> | <u>PAGE</u> |
|--|-------------|
| Warranty | 2 |
| 1.0 General | 3 |
| 1.1 Equipment Description | 3 |
| 1.2 Technical Characteristics | 4 |
| 1.3 Monitor & Control Interface | 5 |
| 2.0 Installation | 8 |
| 2.1 Mechanical | 8 |
| 2.2 Rear I/O's | 9 |
| 2.3 Front Panel Controls, Indicators | 9 |
| 2.4 Operation | 10 |
| 2.5 Menu Settings | 11 |
| 3.0 Environmental Use Information | 16 |

WARRANTY - The following warranty applies to all Cross Technologies, Inc. products.

All Cross Technologies, Inc. products are warranted against defective materials and workmanship for a period of one year after shipment to customer. Cross Technologies, Inc.'s obligation under this warranty is limited to repairing or, at Cross Technologies, Inc.'s option, replacing parts, subassemblies, or entire assemblies. Cross Technologies, Inc. shall not be liable for any special, indirect, or consequential damages. This warranty does not cover parts or equipment which have been subject to misuse, negligence, or accident by the customer during use. All shipping costs for warranty repairs will be prepaid by the customer. There are not other warranties, express or implied, except as stated herein.



6170 Shiloh Road
Alpharetta, Georgia 30005

(770) 886-8005
FAX (770) 886-7964
Toll Free 888-900-5588

WEB www.crosstechnologies.com
E-MAIL info@crosstechnologies.com

MODEL 2083-218# Block Translator

1.0 General

1.1 Equipment Description

2083-218# Block Translator - The 2083-218# Block Translator converts a 950-1550 or 1450-2050 block to the 150-750 MHz block with no spectrum inversion, low group delay and flat frequency response. The 950-2050 MHz input is filtered and translated to the 150-750 MHz block output using dual conversion. The gain can be set for -10 to +10 dB, in 1 ±1dB steps. Multifunction switches select the Gain and the translation band which appear on the LCD display and can be adjusted remotely. Front panel LEDs provide indication of DC power (green), PLL alarm (red), and remote operation (yellow). Connectors are BNC female for RF input and output. The external 10 MHz, Option E, includes a 10 MHz output connector which contains either the internal or external 10 MHz reference signal. The unit is powered by a 100-240 ±10% VAC, 47-63 HZ input power supply and housed in a 1 3/4" X 19" X 16" rack mount chassis.

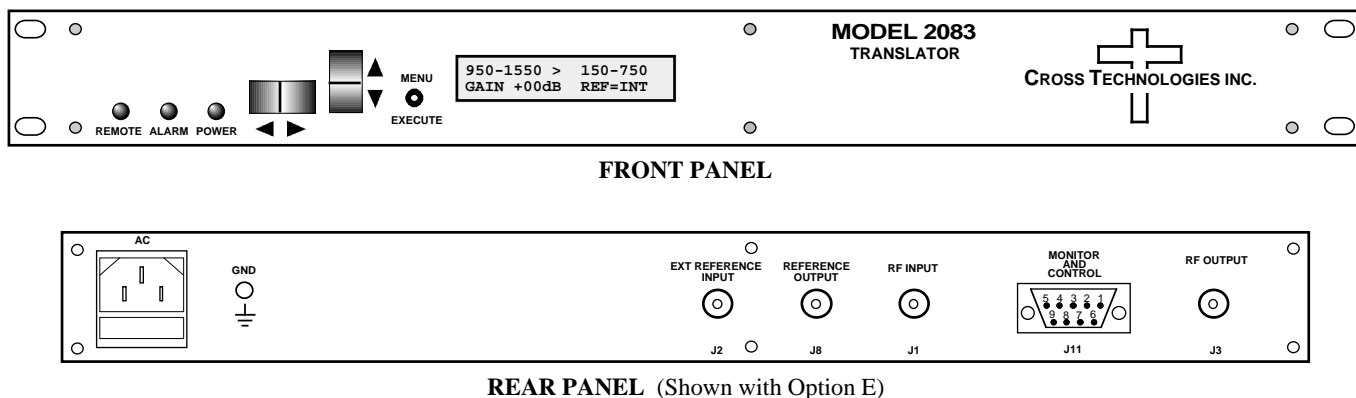

FIGURE 1.1 2083-218# Front and Rear Panels

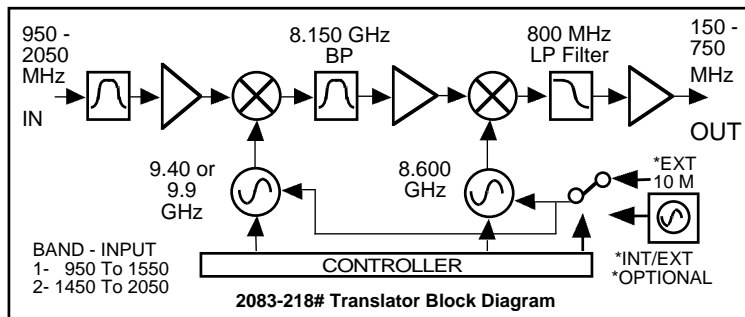

FIGURE 1.2 2083-218# Translator Block Diagram

1.2 Technical Characteristics

| TABLE 1.0 2083-218# Block Translator Specifications* | | | | | |
|---|---|------|---------------------------------|--------|------|
| Input Characteristics | | | | | |
| Input Impedance/RL | 50Ω/12 dB | | | | |
| Bands 1 | 950 - 1550 MHz | | | | |
| Bands 2 | 1450 - 2050 MHz | | | | |
| Input Level | -5 to -25 dBm | | | | |
| Input, maximum no damage | +10 dBm | | | | |
| Output Characteristics | | | | | |
| Impedance/RL | 50Ω / 12 dB | | | | |
| Frequency | 150 - 750 MHz | | | | |
| Output Level | -5 to -25 dBm | | | | |
| Output 1 dB Compression | +5 dBm at maximum gain | | | | |
| Channel Characteristics | | | | | |
| Gain, Maximum, Range | +10 dB, ±2 dB, adjustable from -10 to +10 dB in 1 ±1dB steps | | | | |
| Frequency Response | ±2.0 dB, 600 MHz bandwidth; ±0.5 dB, 36 MHz increment | | | | |
| Spurious, Inband | < -45 dBC in band, 150 - 750 MHz Out | | | | |
| Spurious, 0.95-2.05 GHz | < -45 dBm; < -45 dBC, 0.95 - 2.05 GHz feed through rejection | | | | |
| Group Delay, Maximum | 0.015 ns/MHz ² , Parabolic, 0.03ns/MHz, Linear, 1 ns Ripple, 36 MHz BW | | | | |
| Frequency Sense | Non-inverting | | | | |
| Synthesizer Characteristics | | | | | |
| Frequency Accuracy | ±0.01 ppm | | | | |
| Reference | 10 MHz Internal (External Reference, Option -E) | | | | |
| Phase Noise @ F(Hz) > | 100 MHz | 1kHz | 10kHz | 100kHz | 1MHz |
| dBC/Hz | -70 | -75 | -85 | -95 | -105 |
| Controls, Indicators | | | | | |
| Frequency Translation | Setting Shown on LCD Display | | | | |
| Gain | Direct Readout LCD, Manual or Remote Selection | | | | |
| Power, Alarm, Remote | Green LED; Red LED; Yellow LED | | | | |
| Remote | RS232C, 9600 baud, W8, W18 Ethernet, Optional | | | | |
| Other | | | | | |
| RF In/RF Out Connector | BNC (female) | | | | |
| 10 MHz Connectors (E) | BNC (female); 75Ω, works with 50 or 75 ohms (Option E) | | | | |
| Alarm/Remote Connector | DB9 (female); No or NC contact closure on Alarm | | | | |
| Size | 19 inch Standard Chassis 1.75" high x 16.0" deep | | | | |
| Power | 100-240 ±10% VAC, 47- 63 Hz, 30 watts maximum | | | | |
| Available Options | | | | | |
| E - | External 10 MHz Reference Input and Output | | | | |
| M&C Interface | | | | | |
| Q - | RS485 Remote Interface | | | | |
| W8 - | Ethernet M&C Web Browser Interface | | | | |
| W18 - | Ethernet M&C Web Browser Interface and SNMP | | | | |
| Connector/Impedance | | | | | |
| B - | 75Ω BNC (RF In), 75Ω BNC (RF Out) | | | | |
| *+10°C to +40°C; Specifications subject to change without notice. | | | © 2014 Cross Technologies, Inc. | | |

1.3 Monitor and Control Interface

A) Remote Serial Interface

Protocol: RS-232C, 9600 baud rate, no parity, 8 data bits, 1 start bit, and 1 stop bit.
(RS-232C, RS-422, or RS-485 - **Option Q**)

Connector: Rear panel, DB-9 male

| J10 Pinouts (RS-232C/422/485) | |
|-------------------------------|------------------------------|
| Pin | Function |
| 1 | Rx- |
| 2 | Rx+ (RS-232C) |
| 3 | Tx+ (RS-232C) |
| 4 | Tx- |
| 5 | GND |
| 6 | Alarm Relay: Common |
| 7 | Alarm Relay: Normally Open |
| 8 | Not Used |
| 9 | Alarm Relay: Normally Closed |

B) Status Requests - Table 1.1 lists the status requests for the 2083-218# and briefly describes them.

* PLEASE NOTE: The two character {aa}{00-31} prefix, in the table below, should be used ONLY when RS-485, (OPTION-Q), is selected.

| TABLE 1.1 2083-218# Status Requests | | |
|--|-----------------|--|
| Command | Syntax * | Description |
| Input Frequency Band | {aaSB} | Returns {aaSBx} where: <ul style="list-style-type: none"> • x = 1 if Band 1 (950-1550 MHz) is selected. • x = 2 if Band 2 (1450-2050 MHz) is selected. |
| Output Gain | {aaSG} | Returns {aaSGxxx} where: <ul style="list-style-type: none"> • xxx = RF gain in dB range: -10 to +10 Note: This value is valid when the unit's Gain Mode is set to MGC. |
| Alarm Status | {aaSA} | Returns {aaSAxyz} where: <ul style="list-style-type: none"> • x = 1 if PLL-1 is alarmed, 0 if normal • y = 1 if PLL-2 is alarmed, 0 if normal • z = 1 if summary alarm, 0 if no alarm |
| Model Number & Rev. | {aaSV} | Returns {aaSV2083-228#x.xx} or {aaSV2083-228#x.xx} where: <ul style="list-style-type: none"> • x.xx is the unit's firmware version. |
| Option E: | | |
| 10 MHz Reference Mode | {aaSE} | Returns {aaSEx} where: <ul style="list-style-type: none"> • x = 0 if Internal Reference Mode is selected • x = 1 if External Reference Mode is selected • x = 2 if Auto Reference Mode is selected |
| 10 MHz Reference Status | {aaSI} | Returns {aaSIx} where: <ul style="list-style-type: none"> • x = 0 if Internal Reference is active • x = 1 if External Reference is active |

C) Commands

Table 1.2 lists the commands for the 2083-218# and briefly describes them.

After a command is sent the 2083 sends a return “>” indicating the command has been received and executed.

General Command Format - The general command format is {CND...}, where:

{ = start byte

C = 1 character, either C (command) or S (status)

N = 1 character command or status request

D = 1 character or more of data (depends on command)

} = stop byte

* PLEASE NOTE: The two character {aa}(00-31) prefix, in the table below, should be used ONLY when RS-485, (OPTION-Q), is selected.

| Table 1.2 2083-218# Commands | | |
|------------------------------|-----------|--|
| Set Input Frequency Band | {aaCBx} | where: |
| | | • x = 1 to select Band 1 (950-1550 MHz) . |
| | | • x = 2 to select Band 2 (1450-2050 MHz) . |
| Set Output Gain | {aaCGxxx} | where : |
| | | • xxx = +15 to +45 dB |
| Set Remote On | # | Just # sign |
| Set Remote Off | {aaCRO} | |
| Option E: | | |
| Set 10 MHz Reference Mode | {aaCEx} | where : |
| | | • x = 0 to Select Internal Reference Mode |
| | | • x = 1 to Select External Reference Mode |
| | | • x = 2 to Select Auto Reference Mode |

2.0 Installation

2.1 Mechanical

The 2083-218# consists of one RF/Controller PCB housed in a 1 RU (1 3/4 inch high) by 16 inch deep chassis. A switching, ± 12 , +24, +5 VDC power supply provides power for the assemblies. The 2083-218# can be secured to a rack using the 4 holes on the front panel. Figure 2.0 shows how the 2083-218# is assembled.

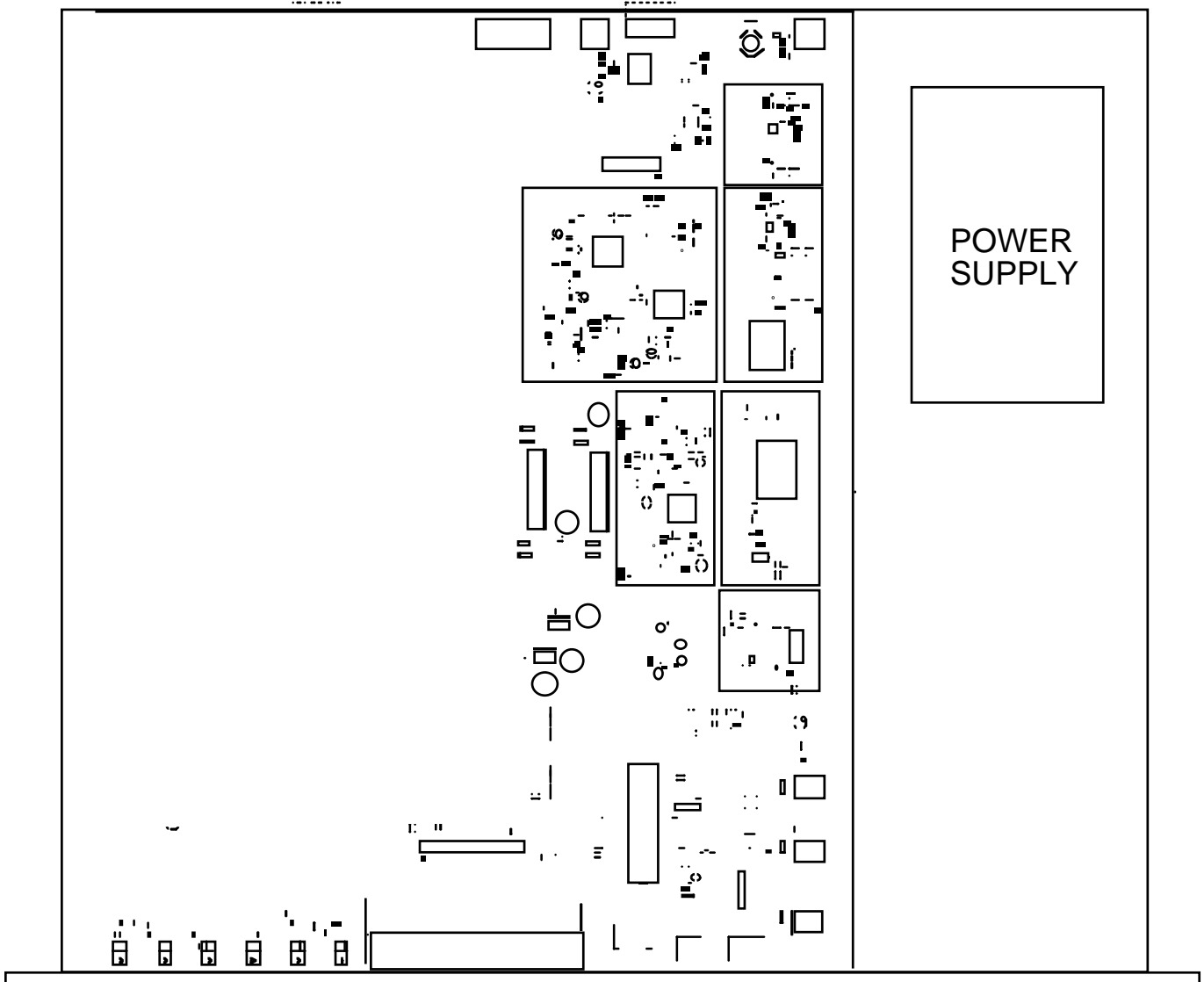

FIGURE 2.0 2083-218# Mechanical Assembly

2.2 Rear Panel Input/Output Signals

Figure 2.1 shows the input and output connectors on the rear panel.

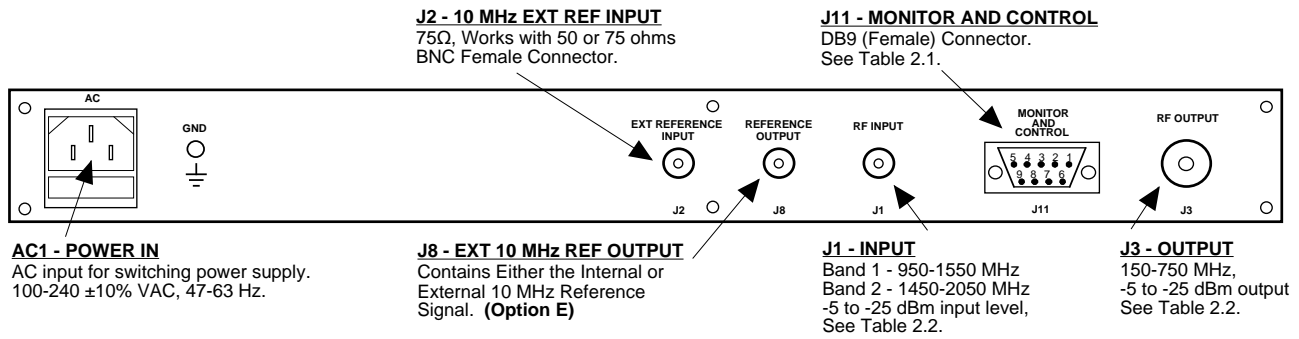

FIGURE 2.1 2083-218# Rear Panel I/O's

| TABLE 2.1 J10 Pinouts* | |
|------------------------|------------------------------|
| Pin | Function |
| 1 | Rx- |
| 2 | Rx+ (RS-232C) |
| 3 | Tx+ (RS-232C) |
| 4 | Tx- |
| 5 | GND |
| 6 | Alarm Relay: Common |
| 7 | Alarm Relay: Normally Open |
| 8 | Not Used |
| 9 | Alarm Relay: Normally Closed |

| TABLE 2.2 Input/Output Connector Options | | |
|--|----------|----------|
| Option | Input | Output |
| B | BNC, 75Ω | BNC, 75Ω |

*Remote Serial Interface

Interface: DB-9 Male Protocol: RS-232C (RS-232C/422/485, option Q), 9600 baud rate, no parity, 8 data bits, 1 start bit, 1 stop bit.

2.3 Front Panel Controls and Indicators

Figure 2.2 shows the front panel controls and indicators.

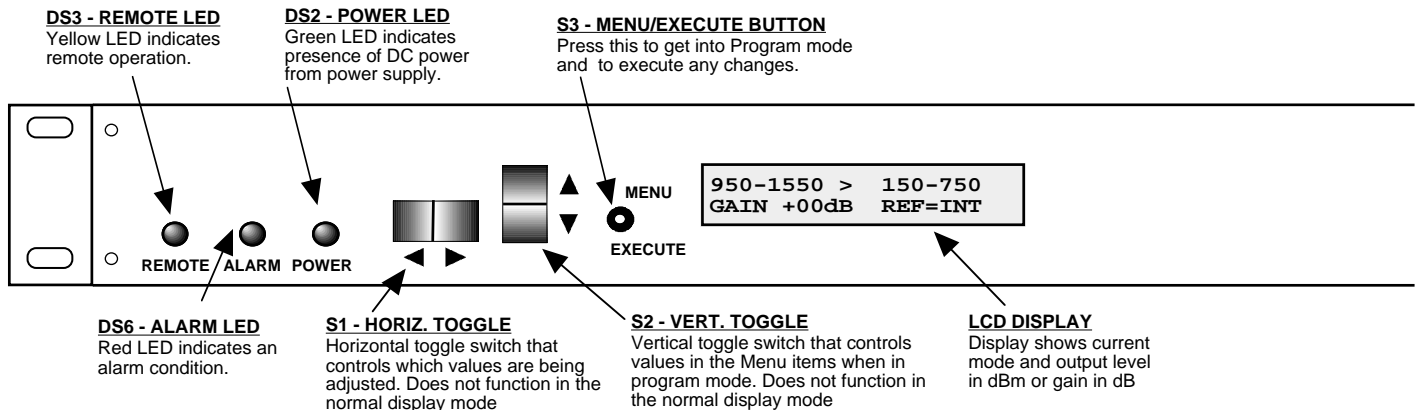

FIGURE 2.2 2083-218# Front Panel Controls and Indicators

2.4 Installation / Operation

2.4.1 Installing and Operating the 2083-218#, Frequency Translator Section

1. Connect a -5 dBm to -25 dBm signal to RF IN, J1 (Figure 2.1)
2. Connect the RF OUT, J3, to the external equipment
3. Connect 100-240 \pm 10% VAC, 47 - 63 Hz to AC connector on the back panel.
4. Set the gain for -10 to +10 dB. Make sure the output stays within -5 to -25 dBm with the gain selected and the input level provided. (See Section 2.5 Menu Settings).
5. Be sure DS6 (green, DC Power) is on and DS2 (red, Alarm) is off (Figure 2.2).
6. AC Fuse - The fuse is a 5 mm X 20 mm, 2 amp slow blow (Type T) and is inserted in the far slot in the drawer below the AC input as shown in Figure 2.3. There is a spare fuse in the near slot.

NOTE: If a fuse continues to open, the power supply is most likely defective.

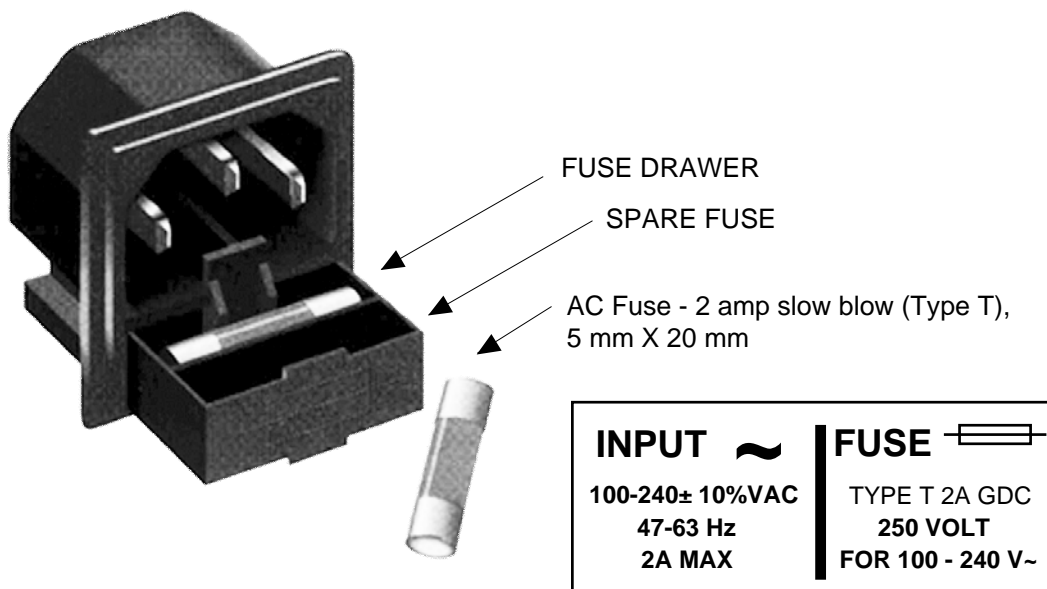

FIGURE 2.3 Fuse Location and Spare Fuse

2.5 Menu Settings

2.5.1 Functions

This section describes operation of the front panel controls. There are three operator switches, the LCD display and alarm indicator LEDs. All functions for the equipment are controlled by these components. The functions are (See Figure 2.4):

Power Up

Normal Display

- Menu 1** Set Input Frequency Band
- Menu 2** Set Gain
- Menu 3** Set 10 MHz Reference Mode (Option E only)
- Menu 4** Set Remote
- Menu 5** Set Remote Interface (Option Q only)
- Menu 6** Set RS-485 Address (Option Q only)

Save Menu When “R” is selected from any above menu or at the end.

Alarm indications appear on the LEDs (see Figure 2.2).

All program changes must start with the operation of the Menu/Execute switch and must also end with the operation of the Menu/Execute switch verified by the “Save Settings?” Menu. If this sequence is not followed, none of the changes will take effect. If programming is initiated and no operator action takes place for approximately 30 seconds (before the final press of the Menu/Execute switch) the display will revert to its previous status and you will need to start over.

2.5.2. Power On Settings

NOTE: THE LAST OPERATING PARAMETERS OF A UNIT ARE RETAINED EVEN WHEN POWER IS REMOVED. WHEN POWER IS RESTORED, THE UNIT WILL RETURN TO IT'S PREVIOUS SETTINGS.

When power is first applied, the LCD display goes through three steps.

1. The LCD goes black to show all segments are functioning.
2. The Model and Software version will be displayed.

| |
|------------------------|
| 2083-218# Rev. 1.00 |
|------------------------|

3. The present frequency and gain of the upconverter is shown.

| | |
|------------|-----------|
| 950 -1550> | 150-750 |
| GAIN +00dB | REF = INT |

The unit is now operational and ready for any changes the operator may desire.

2.5.3 Control Switches

1. **Menu/Execute** - Any change to the programming of the unit must be initiated by pressing the Menu/Execute switch and completed by pressing the Menu/Execute switch.
2. **Horizontal Switch** - This switch is mounted so its movement is horizontal and moves the display cursor left or right.
3. **Vertical Switch** - This switch is mounted so its movement is vertical and has two functions:
 - a. During gain changes, the vertical movement will raise or lower the number in the direction of the arrows.
 - b. For other functions such Remote on/off, the vertical switch will alternately turn the function ON or OFF regardless of the direction operated.

2.5.4 Gain Changes

When you get to this menu note that the gain changes will be made as you make them but if you do not wish to save the changes you have made, scroll to “**R**” and push the menu/Execute switch and select “**NO**” in the “**SAVE SETTINGS?**” window or **do not press the Menu/Execute switch**; simply do nothing for approximately 30 seconds, and the system will return to the normal operating mode.

NOTE: CHANGES TAKE PLACE ON GAIN IMMEDIATELY BUT DO NOT GET SAVED UNTIL YOU GO TO THE SAVE MENU AND INDICATE YOU WANT TO SAVE THE CHANGES.

Press the Up/Down switch to change the gain in 1 or 10 dB steps and then push the Menu/Execute switch to get to the Save Settings Menu:

| |
|------------------------------|
| OUTPUT LEVEL = -0 <u>5</u> R |
|------------------------------|

or by using the horizontal rocker switch the cursor can be moved left or right.

| |
|---------------------------------|
| GAIN = +1 <u>0</u> R |
|---------------------------------|

Pressing the Up/Down switch down will toggle the display digit selected until you have the desired gain.

NOTE: THE GAIN WILL BE CHANGED AS YOU ADJUST THE NUMBERS. HOWEVER, THE VALUE WILL NOT BE STORED UNTIL YOU INDICATE YES IN THE SAVE SETTINGS WINDOW. DO NOT SET A GAIN THAT WOULD EXCEED -5 dBm OR HAVE LESS THAN -25 dBm OUTPUT LEVEL.

When the display indicates the value desired you can push the Menu/Execute switch to the next item OR you can scroll to “**R**”, push the Menu/Execute switch to get to:

| |
|---------------------------|
| SAVE SETTINGS? <u>Y</u> N |
|---------------------------|

Selecting **Y** will save the new settings. Selecting **N** will revert to the previous settings.

Figure 2.4 gives the menu items and how to make changes

2.5.5 Alarm Indications

An alarm condition will occur if any local oscillator phase lock loop (PLL) comes out of lock. The Remote LED will light when you select the Remote mode.

2.5.6 10 MHz Reference Mode Operation

Internal Mode: The unit uses its own built-in 10 MHz OCXO. The Internal Reference is present on the Reference Output Connector, J8. REF = INT appears on the front panel display.

External Mode: The unit uses a 10 MHz Reference that is connected to the External Reference Input, J2. REF = EXT appears on the front panel display. The External 10 MHz Reference level must be +3dBm, ± 3 dB. If the External 10 MHz signal does not meet the unit's specified parameters then the unit will not function properly. The External Reference is present on the Reference Output connector, J8.

Auto Mode: The unit defaults to the External 10 MHz Reference as long as the level meets the +3dBm, ± 3 dB specification. REF = AUTO - E appears on the front panel display where the -E indicates that the unit is using the External 10 MHz Reference. The External Reference is present on the Reference Output connector, J8.

If the external 10 MHz Reference signal level is less than -1dBm, the unit switches to Internal 10 MHz Reference. REF = AUTO -I appears on the front panel display where -I indicates that the unit is using the Internal 10 MHz Reference. The Internal 10 MHz Reference is present on the Reference Output connector, J8.

| | | | |
|--|--|-----------------------|-------------|
| | ON POWER UP | | |
| Power Up | 2083-218# REV 1.00 | | |
| | | | |
| | NORMAL DISPLAY | | |
| Normal Display | 950 - 1550 > 150 - 750 GAIN +00dB REF = INT | | PUSH BUTTON |
| | | | |
| | PUSHING MENU/EXECUTE SEQUENCE | | |
| Menu 1 Set Input Frequency Band | INPUT FREQUENCY = R 95 <u>0</u> - 1550 | SCROLL <> SCROLL ↻ | PUSH BUTTON |
| Menu 2 Set Gain | GAIN = +1 <u>0</u> R | SCROLL <> SCROLL ↻ | PUSH BUTTON |
| Menu 3 Set 10 MHz Reference Mode | REF MODE = <u>A</u> UTO R | SCROLL <> SCROLL ↻ | PUSH BUTTON |
| Menu 4 Set Remote | REMOTE = <u>O</u> N R | SCROLL <> SCROLL ↻ | PUSH BUTTON |
| Menu 5 Set Remote Interface (Option -Q only) | INTERFACE = <u>R</u> S232 R | SCROLL <> SCROLL ↻ | PUSH BUTTON |
| Menu 6 Set RS485 Address (Option -Q only) | RS485 ADDRESS = <u>0</u> 0 R | SCROLL <> SCROLL ↻ | PUSH BUTTON |
| Save? When go to end | SAVE SETTINGS? <u>Y</u> N | SCROLL <> SCROLL ↻ | PUSH BUTTON |

FIGURE 2.4 Menu Display and Sequences

3.0 Environmental Use Information

- A. **Rack-Mounting** - To mount this equipment in a rack, please refer to the installation instructions located in the user manual furnished by the manufacturer of your equipment rack.
- B. **Mechanical Loading** - Mounting of equipment in a rack should be such that a hazardous condition does not exist due to uneven weight distribution.
- C. **Elevated Operating Ambient Temperature** - If installed in a closed or multi-unit rack assembly, the operating ambient temperature of the rack may be greater than room ambient temperature. Therefore, consideration should be given to Tmra.
- D. **Reduced Air Flow** - Installation of the equipment in a rack should be such that the amount of air flow required for safe operation of the equipment is not compromised. Additional space between units may be required.
- E. **Circuit Overloading** - Consideration should be given to the connection of the equipment to the supply circuit and the effect that overloading of circuits could have on over current protection and supply wiring. Appropriate consideration of equipment name plate rating should be used when addressing this concern.
- F. **Reliable Earthing** - Reliable earthing of rack-mounted equipment should be maintained. Particular attention should be given to supply connections other than direct connection to the Branch (use of power strips).
- G. **Top Cover** - There are no serviceable parts inside the product so, the Top Cover should not be removed. If the Top Cover is removed the ground strap and associated screw **MUST BE REINSTALLED** prior to Top Cover screw replacement. **FAILURE TO DO** this may cause **INGRESS** and/or **EGRESS** emission problems.



6170 Shiloh Road
Alpharetta, Georgia 30005

(770) 886-8005
FAX (770) 886-7964
Toll Free 888-900-5588

WEB www.crosstechnologies.com
E-MAIL info@crosstechnologies.com

Printed in USA