

# Instruction Manual

# Model 2083-2004# Translator

August 2016, Rev. 0

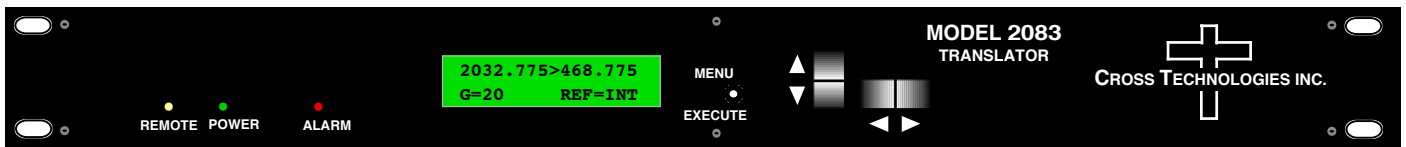

Data, drawings, and other material contained herein are proprietary to Cross Technologies, Inc., but may be reproduced or duplicated without the prior permission of Cross Technologies, Inc. for purposes of operating the equipment. Printed in USA.

When ordering parts from Cross Technologies, Inc., be sure to include the equipment model number, equipment serial number, and a description of the part.



6170 Shiloh Road  
Alpharetta, Georgia 30005

(770) 886-8005  
FAX (770) 886-7964  
Toll Free 888-900-5588

WEB [www.crosstechnologies.com](http://www.crosstechnologies.com)  
E-MAIL [info@crosstechnologies.com](mailto:info@crosstechnologies.com)

**INSTRUCTION MANUAL**  
**MODEL 2083-2004# Translator**

<b>Warranty</b>	<b>2</b>
<b>1.0 General</b>	<b>3</b>
1.1 Equipment Description	<b>3</b>
1.2 Technical Characteristics	<b>4</b>
1.3 Monitor & Control Interface	<b>5</b>
1.4 Environmental Use Information	<b>7</b>
<b>2.0 Installation</b>	<b>8</b>
2.1 Mechanical	<b>8</b>
2.2 Rear Inputs & Outputs	<b>9</b>
2.3 Front Panel Controls & Indicators	<b>10</b>
2.4 Operation	<b>11</b>
2.5 Menu Settings	<b>12</b>

**WARRANTY** - The following warranty applies to all Cross Technologies, Inc. products.

All Cross Technologies, Inc. products are warranted against defective materials and workmanship for a period of one year after shipment to customer. Cross Technologies, Inc.'s obligation under this warranty is limited to repairing or, at Cross Technologies, Inc.'s option, replacing parts, subassemblies, or entire assemblies. Cross Technologies, Inc. shall not be liable for any special, indirect, or consequential damages. This warranty does not cover parts or equipment which have been subject to misuse, negligence, or accident by the customer during use. All shipping costs for warranty repairs will be prepaid by the customer. There are not other warranties, express or implied, except as stated herein.



6170 Shiloh Road  
Alpharetta, Georgia 30005

(770) 886-8005  
FAX (770) 886-7964  
Toll Free 888-900-5588

WEB [www.crosstechnologies.com](http://www.crosstechnologies.com)  
E-MAIL [info@crosstechnologies.com](mailto:info@crosstechnologies.com)

# 2083-2004# Translator

## 1.0 General

### 1.1 Equipment Description

The 2083-2004# Translator converts  $2032.775 \pm 18$  MHz to  $468.775 \pm 18$  MHz with a low side LO (non-inverted spectrum). Push button switches select the gain, and other parameters. Front panel LEDs indicate DC power (green), PLL alarm (red), and Remote operation (yellow). Gain is adjustable over a +20 to +40 dB range in  $1 \pm 1$  dB steps locally via front panel switches and remotely via M&C interface. Parameter selection and gain settings appear on the LCD display. Connectors are BNC female for RF input and for IF (RF Out) and optional external 10 Mhz input and output. The external 10 MHz Option-E includes a 10 MHz output which contains either the internal or external 10 MHz reference signal. It is powered by a  $100-240 \pm 10\%$  VAC power supply, and in a 1 3/4" X 19" X 16" rack mount chassis.

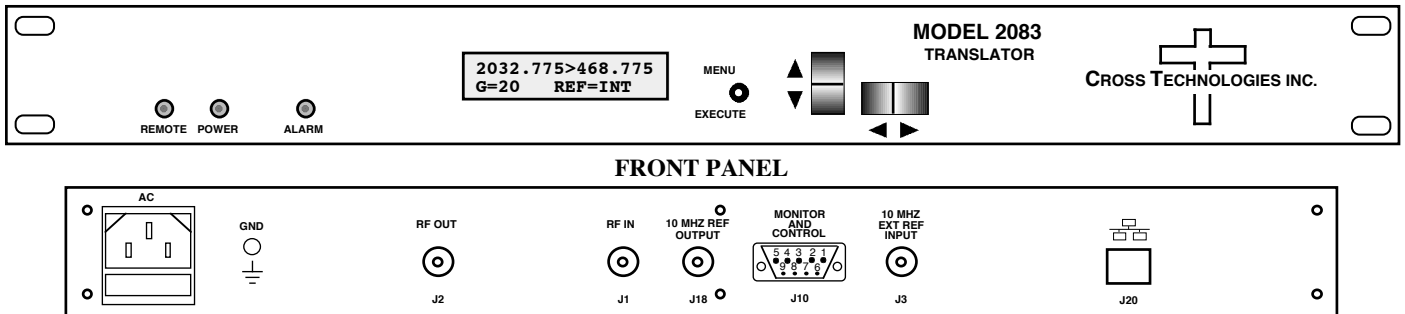

2083-2004# Front and Rear Panels (shown with optional external 10 MHz and Ethernet)

**FIGURE 1.1 Model 2083-2004# Front & Rear Panels**

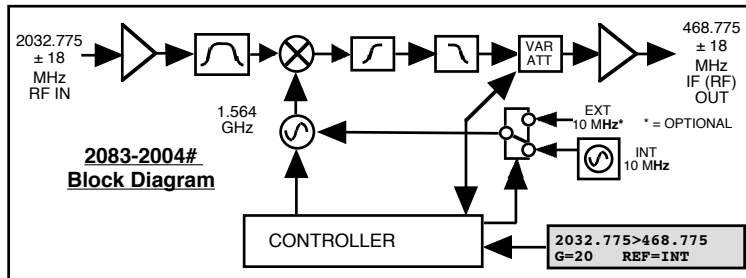

**FIGURE 1.2 Model 2083-2004# Block Diagram**

## 1.2 Technical Characteristics

<b>TABLE 1.0 2083-2004# Translator Specifications*</b>	
<b>Input Characteristics (RF)</b>	
Impedance/Return Loss	50Ω / 12 dB
Frequency	2032.775± 18 MHz
Input Level	-50 to -30 dBm
No Damage Input Level	+15 dBm minimum
<b>Output Characteristics (IF, RF Out)</b>	
Impedance/Return Loss	50Ω / 12 dB
Frequency	468.775 ± 18 MHz
Output Level	-25 to -5 dBm
Output 1 dB Compression	+5 dBm at maximum gain, Gmax
<b>Channel Characteristics</b>	
Gain Range	+40 ±2 dB a Fc max.; manually adjustable from +20 to +40 dB at Fc in 1±1dB
Frequency Response	±0.7 dB, 468.775 ± 18 MHz Out
Spurious, In Band	<-40 dBC, 468.775 ± 18 MHz out; -25 to -5 dBm out
Spurious, Out of Band	< -40 dBm, Fc ± 100 MHz out; LO < -20 dBm; all at Gmax
Frequency Sense	Non_inverting
<b>Synthesizer Characteristics</b>	
Frequency Accuracy	±1.0 ppm maximum over temperature (±0.01 ppm, Option H)
LO Frequency	1.5640 GHz
10 MHz Level (In or Out)	3 dBm, ±3 dB, 75 ohms (Option E)
<b>Available Options</b>	
E -	External 10 MHz Reference In & Out
H -	High Stability (±0.01 ppm) internal reference
<b>Communication Interface/Standard RS232</b>	
Q -	RS485 Remote Interface
W8 -	Ethernet; with Web Browser
W18 -	Ethernet; with Web Browser & SNMP
W28 -	Ethernet; with TCP/IP. Telnet®
<b>Communication/Impedance</b>	
STANDARD	50Ω BNC (RF), 50Ω BNC (IF)
M-	50Ω Type N (RF), 50Ω BNC (IF)
S-	50Ω SMA (RF), 50Ω BNC (IF)
SS-	50Ω SMA (RF), 50Ω SMA (IF)
<b>Contact Cross Technologies, Inc. for other options.</b>	
*10°C to 40°C; Specifications subject to change without notice.	
© Cross Technologies, Inc. 2016	

## 1.3 Monitor and Control Interface

### A) Remote Serial Interface

**Protocol** - RS-485, RS-422 or RS-232C (selectable), 9600 baud rate, no parity, 8 data bits, 1 start bit, 1 stop bit.

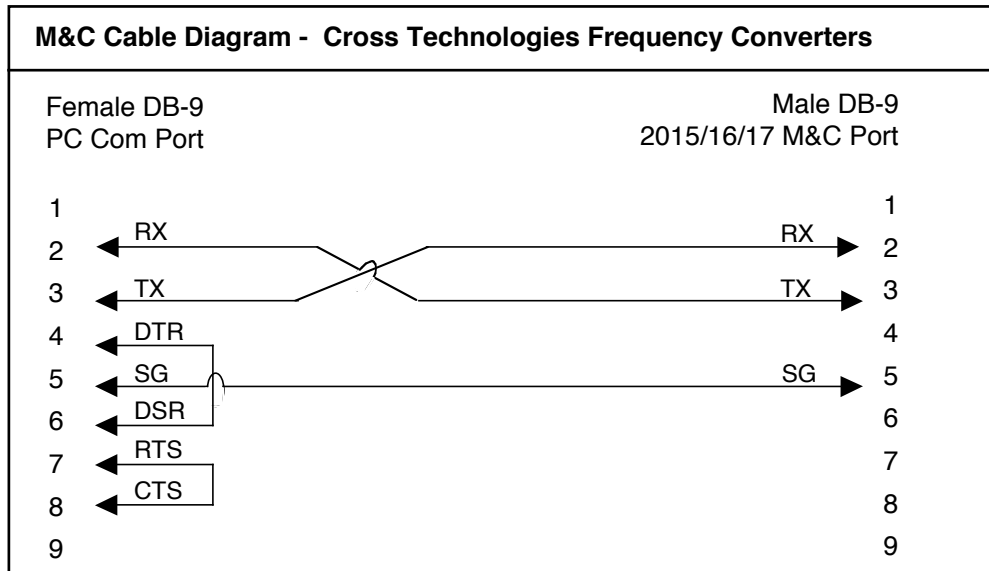

**Connector** - Rear panel, DB-9 female

#### Pinouts (RS-485/422/232C)

Pin	Description
1	Rx-
2	Rx+ (RS-232C)
3	Tx+ (RS-232C)
4	Tx-
5	Ground
6	Alarm Relay - Common
7	Alarm Relay - Normally Open
8	Not Used
9	Alarm Relay - Normally Closed

**B) Commands** - Table 1.2 lists the commands for the 2083-2004# and briefly describes them. After a command is sent the 2083-2004# sends a return ">" indicating the command has been received and executed.

**General Command Format** - The general command format is {aaCND...}, where:

- { = start byte
- aa = Address (**RS-485 only**)
- C = 1 character, either C (command) or S (status)
- N = 1 character command of status request
- D = 1 character or more of data (depends on command)
- } = stop byte

\* PLEASE NOTE: The two character {aa}(00-31) prefix, in the table below, should be used ONLY when RS-485, (OPTION-Q), is selected.

Table 1.2 2083-2004# Commands		
Command	Syntax	Description
Set Transmit Gain	{aaC3xx}*	where: <ul style="list-style-type: none"> <li>• xx = 2 characters</li> <li>• Range: +20 to +40 (20 dB to 40 dB, in 1±1 dB steps)</li> </ul>
Enable External 10MHz (Option -E)	{aaCEx}* #	where x =: <ul style="list-style-type: none"> <li>• 0 to disable External 10MHz ref signal</li> <li>• 1 to enable External 10MHz ref signal</li> </ul>
Enable Remote	#	Just # sign
Disable Remote	{aaCR0}* #	{CR and zero}

**C) Status Requests** - Table 1.3 lists the status requests for the 2083-2004# and briefly describes them.

\* PLEASE NOTE: The two character {aa}(00-31) prefix, in the table below, should be used ONLY when RS-485, (OPTION-Q), is selected.

Table 1.3 2083-2004# Status Requests		
Command	Syntax	Description
Command Status	{aaS1}* #	Returns {aaS1bbEA} where: <ul style="list-style-type: none"> <li>• bb = Gain</li> <li>• E = External Ref Status (0 = Ext Off, 1 = Ext On)</li> <li>• A = Alarm Status (0 = NO Alarm, 1 = Alarm)</li> </ul>

## 1.4 Environmental Use Information

- A. **Rack-Mounting** - To mount this equipment in a rack, please refer to the installation instructions located in the user manual furnished by the manufacturer of your equipment rack.
- B. **Mechanical loading** - Mounting of equipment in a rack should be such that a hazardous condition does not exist due to uneven weight distribution.
- C. **Elevated operating ambient temperature** - If installed in a closed or multiunit rack assembly, the operating ambient temperature of the rack may be greater than room ambient temperature. Therefore, consideration should be given to Tmra (Maximum Recommended Ambient Temperature).
- D. **Reduced air flow** - Installation of the equipment in a rack should be such that the amount of air flow required for safe operation of the equipment is not compromised. Additional space between units may be required.
- E. **Circuit Overloading** - Consideration should be given to the connection of the equipment to the supply circuit and the effect that overloading of circuits could have on over current protection and supply wiring. Appropriate consideration of equipment name plate rating should be used, when addressing this concern.
- F. **Reliable Earthing** - Reliable earthing of rack-mounted equipment should be maintained. Particular attention should be given to supply connections other than direct connection to the Branch (use of power strips).
- G. **Top Cover** - There are no serviceable parts inside the product so, the Top Cover should not be removed. If the Top Cover is removed the ground strap and associated screw **MUST BE REINSTALLED** prior to Top Cover screw replacement. **FAILURE TO DO** this may cause **INGRESS** and/or **EGRESS** emission problems.

## 2.0 Installation

### 2.1 Mechanical

The 2083-2004# consists of one RF/Controller PCB housed in a 1 RU (1.75 inch high) by 16 inch deep chassis. A switching,  $\pm 12$ , +24, +5 VDC power supply provides power for the assemblies. The 2083-2004# can be secured to a rack using the 4 holes on the front panel. Figure 2.0 shows how the 2083-2004# is assembled.

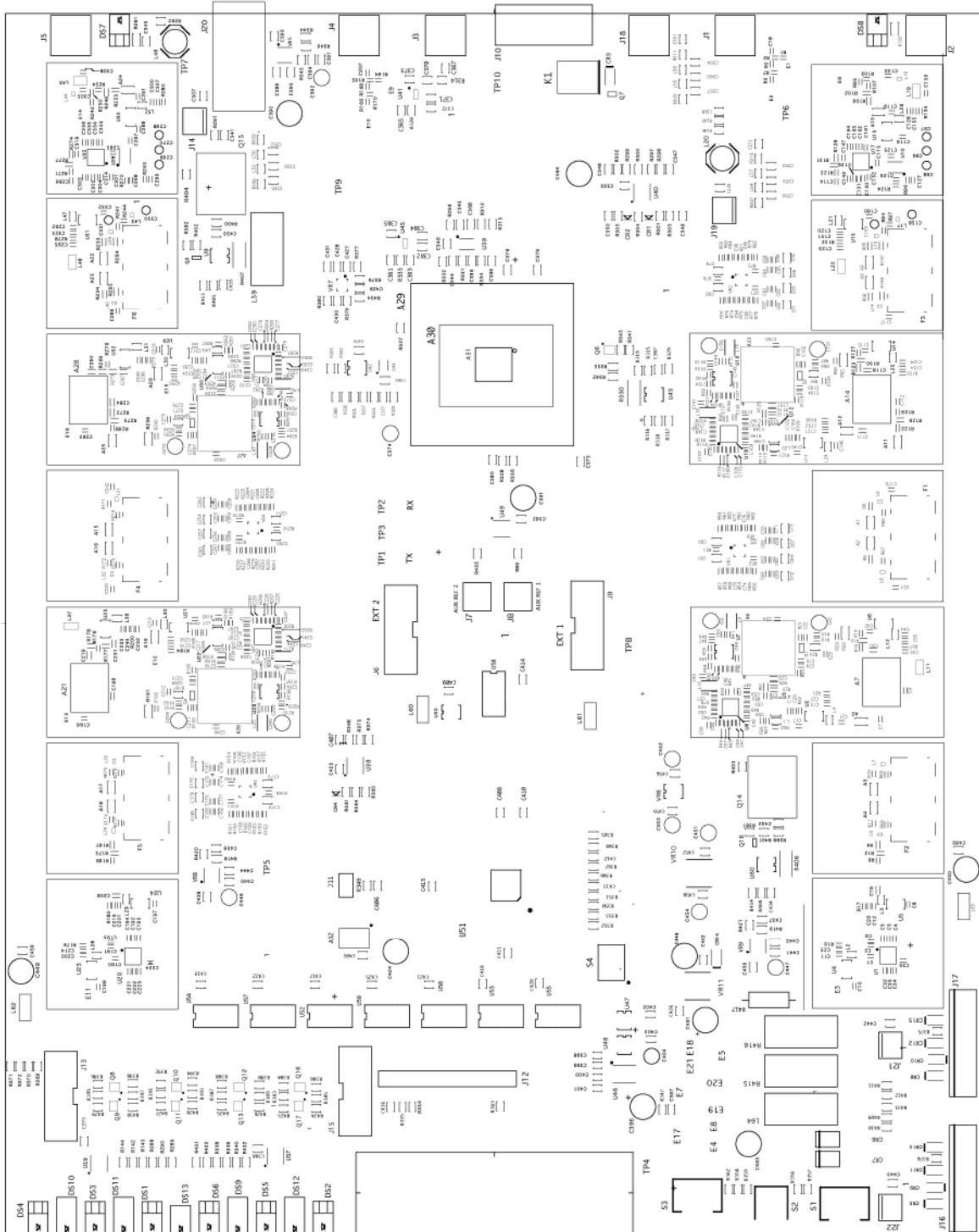
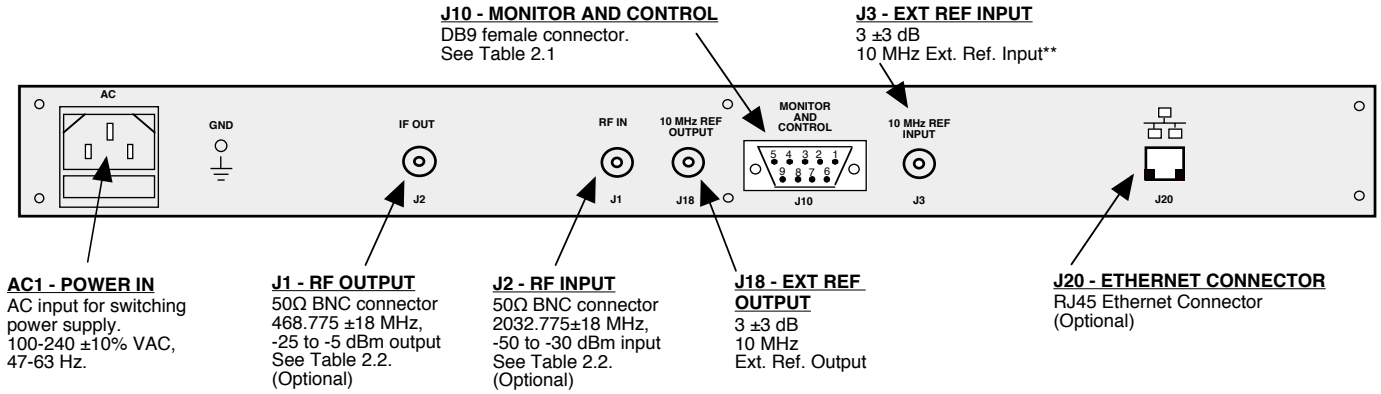

**FIGURE 2.0** 2083-2004# Mechanical Assembly



## 2.2 Rear Panel Input/Output Signals

Figure 2.1 shows the input and output connectors on the rear panel.



**FIGURE 2.1 2083-2004# Rear Panel I/O's**

TABLE 2.1 J10 Pinouts*	
Pin	Function
1	Rx-
2	RS232C
3	RS232C
4	Tx-
5	GND
6	Alarm Relay: Common
7	Alarm Relay: Normally Open
8	Not Used
9	Alarm Relay: Normally Closed

TABLE 2.2 Input/Output Connector Options		
Option	Input	Output
STD	50Ω, N	50Ω, BNC
D	50Ω, BNC	50Ω, BNC
SS	50Ω, SMA	50Ω, SMA

### \*Remote Serial Interface

Interface: DB-9 Male

Protocol: RS232C (RS232C/422/485 **Option Q**),

9600 baud rate, no parity, 8 data bits, 1 start bit, 1 stop bit.

## 2.3 Front Panel Controls & Indicators

Figure 2.2 shows the front panel indicators.

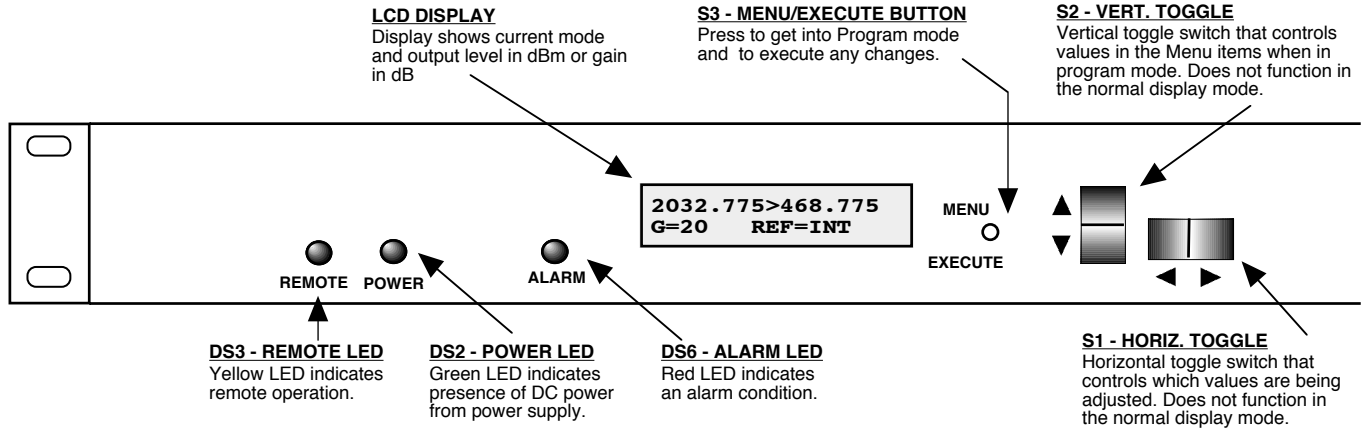

**FIGURE 2.2** 2083-2004# Front Panel Indicators

## 2.4 Installation / Operation

### 2.4.1 Installing and Operating the 2083-2004#, Translator Section

1. Connect a -50 dBm to -30 dBm signal to IN, J2 (Figure 2.1)
2. Connect the OUT, J1, to the external equipment.
3. Connect 100-240  $\pm$ 10% VAC, 47 - 63 Hz to AC on the back panel.
4. Be sure DS2 (green, DC Power) is on and DS6 (red, Alarm) is off (Figure 2.2).
5. AC Fuse - The fuse is a 5 mm X 20 mm, 2 amp slow blow (Type T) and is inserted in the far slot in the drawer below the AC input as shown in Figure 2.3. There is a spare fuse in the near slot.

**NOTE:** If a fuse continues to open, the power supply is most likely defective.

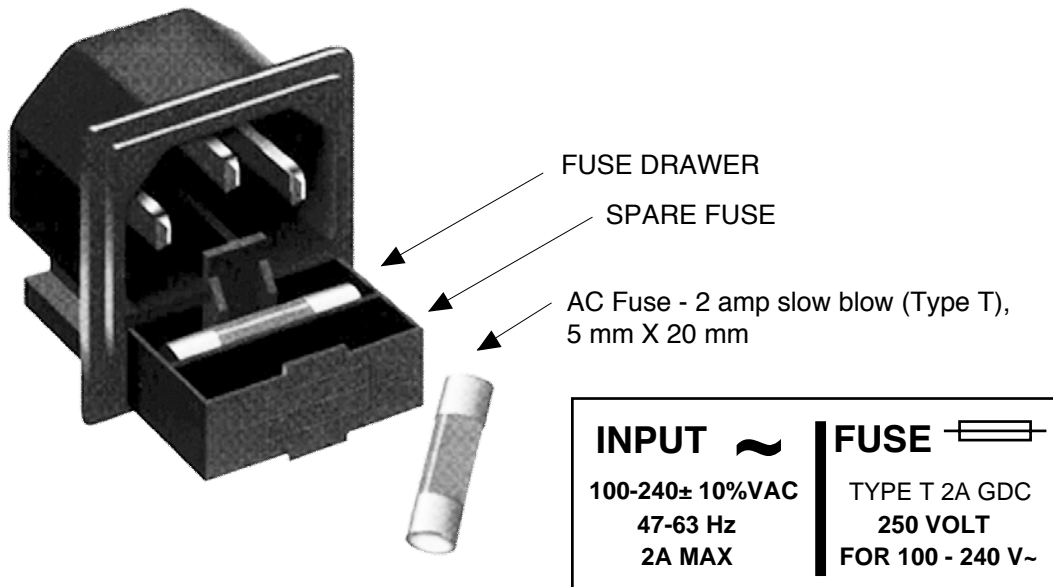

**FIGURE 2.3 Fuse Location and Spare Fuse**

## 2.5 Menu Settings

**2.5.1 Functions** - This section describes operation of the front panel controls. There are three operator switches, the LCD display and alarm indicator LEDs. All functions for the equipment are controlled by these components. The functions are (see Figure 2.5):

### Power Up

### Normal Display

**Menu 1** Set Gain in dB (+20 to +40.0) at Fc in 1  $\pm$ 1 dB steps)

**Menu 2** Set Unit to Remote Operation

**Menu 3 (Opt-E)** Select External 10 MHz Reference

**Save Menu** When “R” is selected in any of the above menus or when operator reaches the end

Alarm indications appear on the LEDs (see figure 2.2).

All program changes must start with the operation of the Menu/Execute switch and must also end with the operation of the Menu/Execute switch verified by the “Save Settings?” Menu. If this sequence is not followed, none of the changes will take effect. If programming is initiated and no operator action takes place for approximately 12 seconds (before the final press of the Menu/Execute switch) the display will revert to its previous status and you will need to start over.

## 2.5.2. Power On Settings

**NOTE:** The last status of a unit is retained even when power is removed. When power is restored, the unit will return to it's previous settings.

When power is first applied, the LCD display goes through three steps.

- 1.The LCD goes black to show all segments are functioning.
- 2.The software version will be displayed.



REV 1.00

- 3.The translation, gain, and selected reference input of the translator is shown.



2032.775>468.775  
G=20 REF=INT

The unit is now operational and ready for any changes the operator may desire.

## 2.5.3 Control Switches

1. Menu/Execute - Any change to the programming of the unit must be initiated by pressing the Menu/Execute switch and completed by pressing the Menu/Execute switch.
2. Horizontal Switch - This switch is mounted so its movement is horizontal and moves the cursor left or right.
3. Vertical Switch - This switch is mounted so its movement is vertical and has two functions:
  - A) During gain changes, the vertical movement will raise or lower the number in the direction of the arrows.
  - B) For other functions such as REF on/off, the vertical switch will alternately turn the function on or off regardless of the direction operated.

## 2.5.4 Gain Changes

When you get to this menu note that the gain changes will be made as you make them but if you do not wish to save the changes you have made, scroll to “**R**” and push the menu/Execute switch and select “**NO**” in the “**SAVE SETTINGS?**” window or **do not press the Menu/Execute switch**; simply do nothing for approximately 12 seconds, and the system will return to the normal operating mode.

**NOTE: CHANGES TAKE PLACE ON LEVEL AND GAIN IMMEDIATELY BUT DO NOT GET SAVED UNTIL YOU GO TO THE SAVE MENU AND INDICATE YOU WANT TO SAVE THE CHANGES.**

G= 20	R
-------	---

By using the horizontal rocker switch the cursor can be moved left or right. Pressing the Up/Down switch down will toggle the display digit selected until you have the desired gain.

**NOTE: THE GAIN WILL BE CHANGED AS YOU ADJUST THE NUMBERS. HOWEVER, THE VALUE WILL NOT BE STORED UNTIL YOU INDICATE YES IN THE SAVE SETTINGS WINDOW. DO NOT SET A GAIN THAT WOULD EXCEED 0 dBm OR HAVE LESS THAN -20 dBm OUTPUT LEVEL. THE FIRMWARE PREVENTS YOU FROM THIS.**

When the display indicates the value desired you can push the Menu/Execute switch to the next item OR you can scroll to “**R**”, push the Menu/Execute switch to get to:

SAVE SETTINGS?	<u>Y</u> N
----------------	------------

Selecting **Y** will save the new settings. Selecting **N** will revert to the previous settings.

Pushing the Menu/Execute switch then takes you to:

2032.775>468.775
G=20 REF=INT

Figure 2.4 gives the menu items and how to make changes.

### 2.5.5 Alarm Indications

An alarm condition will occur if the local oscillator phase lock loop (PLL) comes out of lock. The Mute LED will light if you select to mute the Tx Signal and the Remote LED will light when you select the Remote mode.

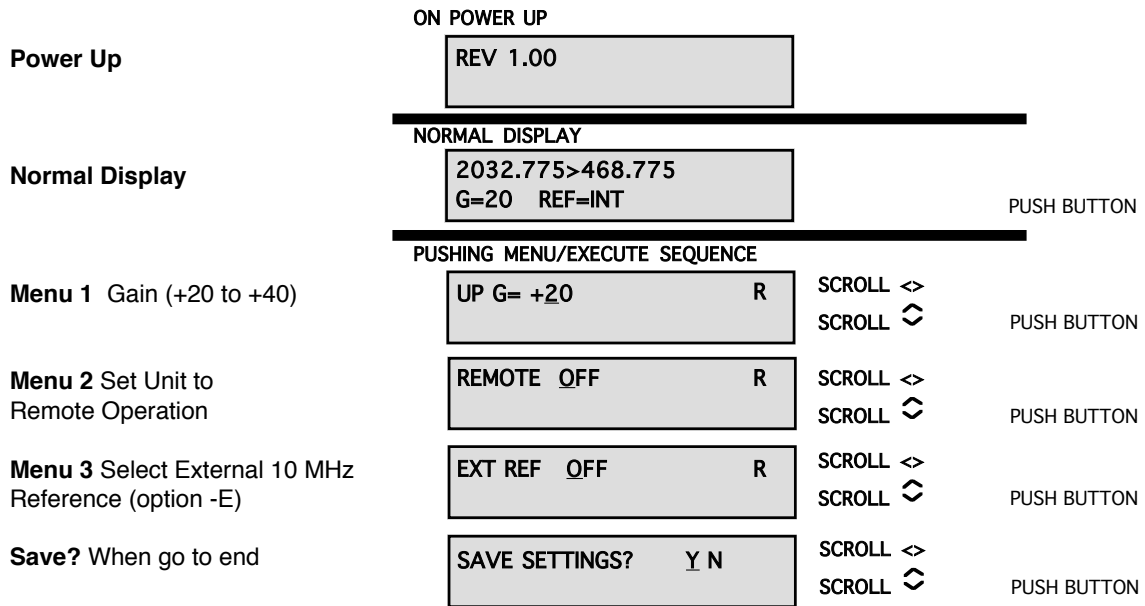

**FIGURE 2.4 Menu Display and Sequence**

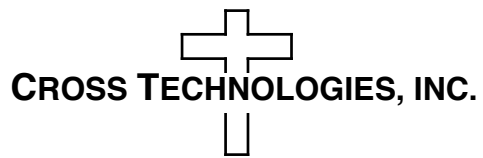

6170 Shiloh Road  
Alpharetta, Georgia 30005

(770) 886-8005  
FAX (770) 886-7964  
Toll Free 888-900-5588

WEB [www.crosstechnologies.com](http://www.crosstechnologies.com)  
E-MAIL [info@crosstechnologies.com](mailto:info@crosstechnologies.com)

Printed in USA