

Instruction manual

Model 2083-1610 Block Translator

November 2018, Rev. A

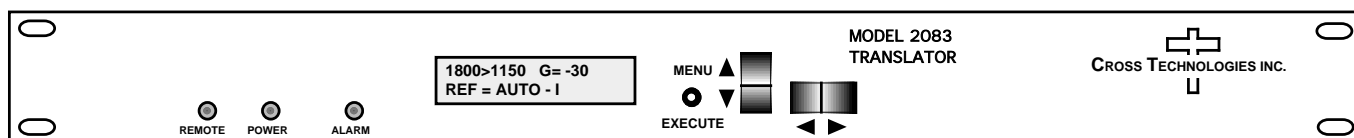

Data, drawings, and other material contained herein are proprietary to Cross Technologies, Inc., but may be reproduced or duplicated without the prior permission of Cross Technologies, Inc. for purposes of operating the equipment.

When ordering parts from Cross Technologies, Inc., be sure to include the equipment model number, equipment serial number, and a description of the part.



6170 Shiloh Road
Alpharetta, Georgia 30005

(770) 886-8005
FAX (770) 886-7964
Toll Free 888-900-5588

WEB www.crosstechnologies.com
E-MAIL info@crosstechnologies.com

INSTRUCTION MANUAL

MODEL 2083-1610 Block Translator

| <u>TTABLE OF CONTENTS</u> | <u>PAGE</u> |
|------------------------------------------|-------------|
| Warranty | 2 |
| 1.0 General | 3 |
| 1.1 Equipment Description | 3 |
| 1.2 Technical Characteristics | 4 |
| 1.3 Monitor & Control Interface | 6 |
| 2.0 Installation | 11 |
| 2.1 Mechanical | 11 |
| 2.2 Rear I/O's | 12 |
| 2.3 Front Panel Controls, Indicators | 13 |
| 2.4 Operation | 14 |
| 2.5 Menu Settings | 15 |
| 3.0 Environmental Use Information | 19 |

WARRANTY - The following warranty applies to all Cross Technologies, Inc. products.

All Cross Technologies, Inc. products are warranted against defective materials and workmanship for a period of one year after shipment to customer. Cross Technologies, Inc.'s obligation under this warranty is limited to repairing or, at Cross Technologies, Inc.'s option, replacing parts, subassemblies, or entire assemblies. Cross Technologies, Inc. shall not be liable for any special, indirect, or consequential damages. This warranty does not cover parts or equipment which have been subject to misuse, negligence, or accident by the customer during use. All shipping costs for warranty repairs will be prepaid by the customer. There are not other warranties, express or implied, except as stated herein.



6170 Shiloh Road
Alpharetta, Georgia 30005

(770) 886-8005
FAX (770) 886-7964
Toll Free 888-900-5588

WEB www.crosstechnologies.com
E-MAIL info@crosstechnologies.com

MODEL 2083-1610 Block Translator

1.0 General

1.1 Equipment Description

2083-1610 Block Translator - The 2083-1610 Block Translator converts a 1600-2000 MHz block to 950-1350 MHz block with no spectrum inversion, low group delay and flat frequency response. The 1600-2000 MHz input is mixed with synthesized local oscillator (LO) signals, first to 2800 MHz center frequency and finally to the 950-1350 MHz block output. The gain can be set for 0 to -20 dB in 0.5 ± 0.5 dB increments. Multifunction switches select the Gain and internal or External (Option E) 10 MHz reference which appear on the LCD display and can be adjusted remotely. Front panel LEDs provide indication of DC power (green), PLL alarm (red), and remote operation (yellow). Connectors are BNC female for RF input and output. The unit is powered by a 100-240 $\pm 10\%$ VAC, 47-63 HZ input power supply and housed in a 1 3/4" X 19" X 16" rack mount chassis.

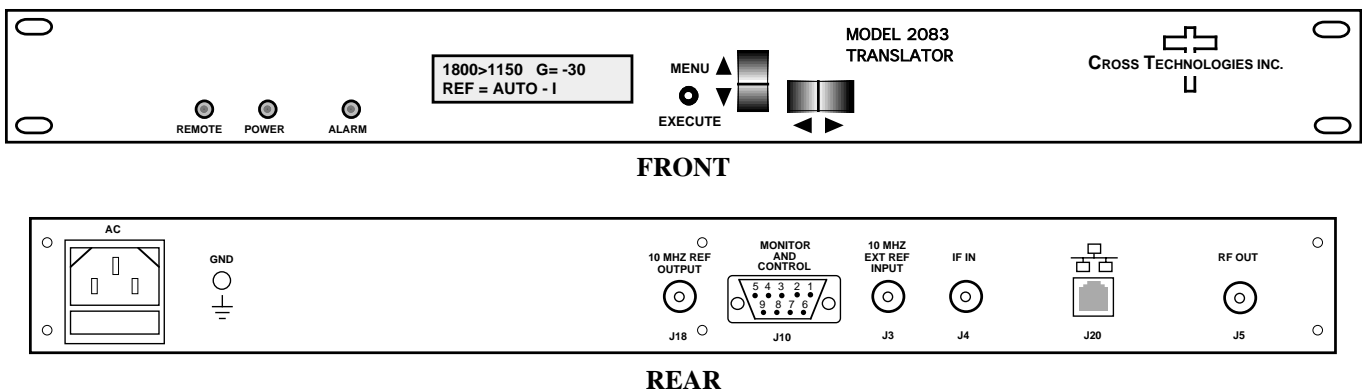

FIGURE 1.1 Model 2083-1610 Front and Rear Panels
(Shown with optional Ethernet & Option E)

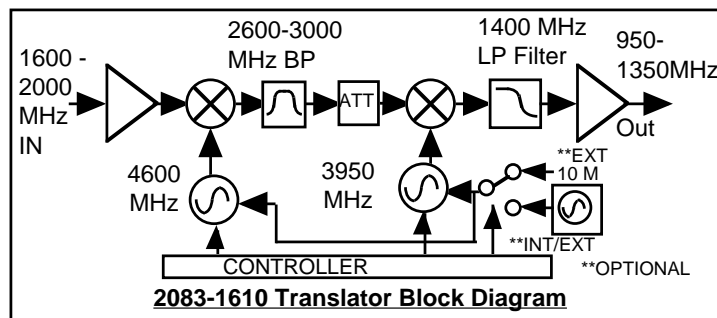

FIGURE 1.2 Model 2083-1610 Translator Block Diagram

1.2 Technical Characteristics

| TABLE 1.0 2083-1610 Block Translator Specifications* | | | | | |
|--------------------------------------------------------------------|-----------------------------------------------------------------------------------------------------------|------|-------|--------|------|
| Input Characteristics | | | | | |
| Input Impedance/RL | 50Ω/12 dB | | | | |
| Frequency | 1600 - 2000 MHz | | | | |
| Maximum input Level Setting | -20 to -40 in 1 +1 dB steps | | | | |
| Input Level Range | 0 to -20 dB below MAX IN setting | | | | |
| Noise Figure, Maximum | 15 dB at -20 dBm MAX IN setting | | | | |
| Output Characteristics | | | | | |
| Impedance/RL | 50Ω / 12 dB | | | | |
| Frequency | 950 - 1350 MHz | | | | |
| Output Composite Level | -20 to -60 dBm (MAX IN -20 to -40) | | | | |
| Output 1 dB compression | -10 dBm, at maximum gain | | | | |
| Channel Characteristics | | | | | |
| Gain | 0 ± 1 dB at Fc and MAX IN set to -20 dBm | | | | |
| Frequency Response | ± 1.5 dB, 400 MHz bandwidth; ± 0.5 dB, any 40 MHz increment | | | | |
| Spurious-Inband (Note 2) | < -50 dBc in band, signal dependent & signal independent; -20dBm out; See NOTE 1 | | | | |
| Spurious-Out of Band (Note 2) | < -30 dBc, 0.5- 0.94 GHz and 1.36-2.1 GHz and 1.60-2.00 GHz feed through; -20 dBm out; See NOTE 1* below. | | | | |
| Frequency Sense | Non-inverting | | | | |
| Group Delay | < 2ns, band; < 1ns, any 65MHz | | | | |
| | *NOTE 1: dBc is relative to the COMPOSITE Output Level | | | | |
| | *NOTE 2: Spurs over MAX IN to MAX IN -20dB Range | | | | |
| Synthesizer Characteristics | | | | | |
| Translation; Accuracy | 1ppm; Option -H, ±0.01 ppm | | | | |
| Reference | 10 MHz Internal; Option -E, Internal / External selection; External Level 3±3 dBm | | | | |
| Frequency Step | None, fixed frequency | | | | |
| Phase Noise @ Frequency | 100 MHz | 1kHz | 10kHz | 100kHz | 1MHz |
| dBC/Hz | -70 | -70 | -80 | -90 | -100 |
| Controls, Indicators | | | | | |
| Fc Translation | Direct readout LCD; manual or remote selection | | | | |
| Maximum IN Level | Direct readout LCD; manual or remote selection | | | | |
| External Ref. (Option -E) | Direct readout LCD; manual or remote selection | | | | |
| Power, Alarm; Remote | Green LED; Red LED; Yellow LED | | | | |
| Remote | RS232C, 9600 Baud; RS485, Ethernet Options | | | | |
| Other | | | | | |
| RF In/RF Out Connector | BNC (female) | | | | |
| 10 MHz Connector | BNC (female); 75Ω, works with 50 or 75 ohms | | | | |
| Alarm/Remote Connector | DB9 (female); NO or NC contact closure on Alarm | | | | |
| Size | 19 inch Standard Chassis 1.75" high x 16.0" deep | | | | |
| Power | 100-240 (±10%) VAC, 47- 63 Hz, 30 watts maximum | | | | |
| Available Options (see page 5...) | | | | | |
| **+10°C to +40°C; Specifications subject to change without notice. | | | | | |
| Cross Technologies, Inc. 2018 | | | | | |

1.2 Technical Characteristics, continued...

| Available Options (2083-1610 Block Translator) | |
|-------------------------------------------------------|---------------------------------------------------|
| E - | External 10 MHz Input and Output |
| H - | High Stability (± 0.01) Internal Reference |
| Communication Interface / Standard RS232 | |
| Q - | RS485 Remote Interface |
| W8 - | Ethernet; with Web Browser |
| W18 - | Ethernet; with Web Browser & SNMP |
| W28 - | Ethernet; with TCP/IP, Telnet® |
| W828 - | Ethernet; W18 + W28 |
| Connectors / Impedance | |
| Std. - | 50 Ω BNC (RF In), 50 Ω BNC (RF Out) |
| NN - | 50 Ω N (RF In), 50 Ω N (RF Out) |
| SS - | 50 Ω SMA (RF In), 50 Ω SMA (RF Out) |
| Contact Cross Technologies for other options. | |

1.3 Monitor and Control Interface

A) Remote Serial Interface

Protocol: RS-232C, 9600 baud rate, no parity, 8 data bits, 1 start bit, and 1 stop bit.
(RS-232C, RS-422, or **RS-485 - option -Q**)

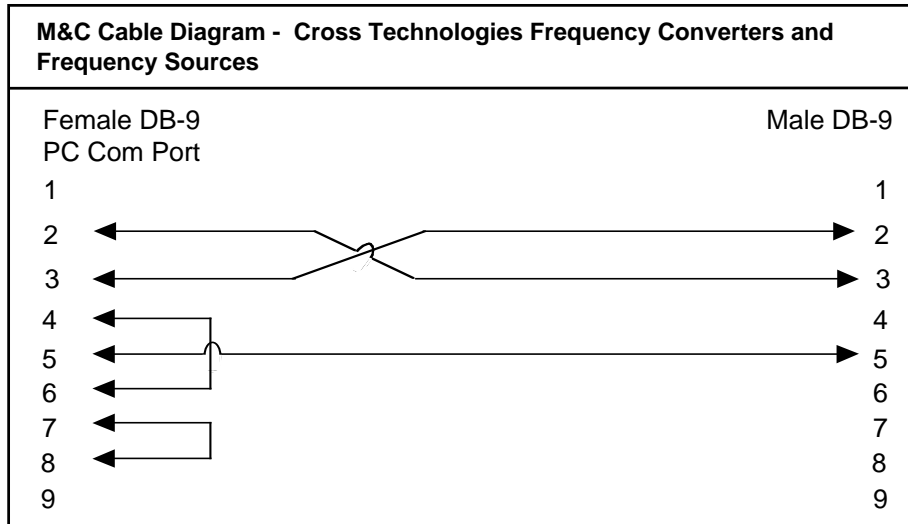

Connector: Rear panel, DB-9 male

| J10 Pinouts (RS-232C/422/485) | |
|-------------------------------|------------------------------|
| Pin | Function |
| 1 | Rx- |
| 2 | Rx+ (RS-232C) |
| 3 | Tx+ (RS-232C) |
| 4 | Tx- |
| 5 | GND |
| 6 | Alarm Relay: Common |
| 7 | Alarm Relay: Normally Open |
| 8 | Not Used |
| 9 | Alarm Relay: Normally Closed |

B) Status Request/Inquiries -

Table 1.0 lists the Status Request/Inquiries for the **2083-0915, 2083-1310, 2083-1610** and briefly describes them.

General Command Format - The general command format is {aaCND...}, where:

{ = start byte

aa = address (**RS-485 only - option -Q**)

C = 1 character, either C (command) or S (status)

N = 1 character command or status request

D = 1 character or more of data (depends on command)

} = stop byte

* PLEASE NOTE: The two character {aa}(00-31) prefix, in the table below, should be used **ONLY** when RS-485, (OPTION-Q), is selected.

| TABLE 1.2 2083-0915 Status Request/Inquiries | | |
|----------------------------------------------|---------|-------------------------------------------------------------------------------------------------------------------------------------------|
| Command | Syntax* | Description |
| Max Input Level Inquiry | {aaSI} | returns: {aaSIxxx} |
| | | where: |
| | | aa = unit address, range = 00 to 31, only used if interface is RS485, otherwise omit |
| | | I = command code |
| | | xxx = maximum input level, range for each model as follows: |
| | | The unit will reply with the '>' character if the command is successfully processed. |
| Reference Mode Inquiry | {aaSE} | returns: {aaSEx} |
| | | where: |
| | | aa = unit address, range = 00 to 31, only used if interface is RS485, otherwise omit |
| | | E = command code |
| | | x = 0 if reference mode is internal, x = 1 if external, |
| | | x = 2 if auto |
| | | The unit will append the '>' character if the command is successfully processed. |
| Reference Status Inquiry | {aaSB} | returns: {aaSBx} |
| | | where: |
| | | aa = unit address, range = 00 to 31, only used if interface is RS485, otherwise omit |
| | | B = command code |
| | | x = 1 if the unit is using the external reference, x = 0 if the unit is using the internal reference |
| | | note: this inquiry is useful if the reference mode is auto and the user wants to know if the unit has switched to the internal reference. |
| | | The unit will append the '>' character if the command is successfully processed. |

Table 1.2, Status Request/Inquiries continued from page7...

| TABLE 1.2 2083-0915 Status Request/Inquiries | | |
|-----------------------------------------------------|----------------|--------------------------------------------------------------------------------------|
| Command | Syntax* | Description |
| Alarm Inquiry | {aaSA} | returns: {aaSAx} |
| | | where: |
| | | aa = unit address, range = 00 to 31, only used if interface is RS485, otherwise omit |
| | | A = command code |
| | | x = 0 if alarm is off, x = 1 if alarm is on. |
| | | The unit will append the '>' character if the command is successfully processed. |
| | | |
| Product/Model Info Inquiry | {aaSV} | returns {aaSV2083-xxxx yyyy ver5.xx} |
| | | where 2083-xxxx = product model |
| | | yyyy = list of options, if any |
| | | "ver" = separates model & options from firmware version |
| | | 5.xx = firmware version |
| | | |

C) Commands - Table 1.0 lists the M&C Commands for the **2083-0915, 2083-1310, 2083-1610** and briefly describes them. After a command is sent the 2083-1310 sends a return ">" indicating the command has been received and executed.

General Command Format - The general command format is {aaCND...}, where:

- { = start byte
- aa = address (**RS-485 only - option -Q**)
- C = 1 character, either C (command) or S (status)
- N = 1 character command or status request
- D = 1 character or more of data (depends on command)
- } = stop byte

* PLEASE NOTE: The two character {aa}(00-31) prefix, in the table below, should be used **ONLY** when RS-485, (OPTION-Q), is selected.

| Table 1.3 2083-0915 M&C Commands | | |
|----------------------------------|-----------|---------------------------------------------------------------------------------------------------------|
| Command Function | Syntax* | Command Description |
| Set Max Input Level | {aaClxxx} | where: |
| | | aa = unit address, range = 00 to 31, |
| | | only used if interface is RS485, otherwise omit |
| | | l = command code |
| | | xxx=maximum input level, range for each model as follows: |
| | | Model 2083-0915: minimum = -25 to -5 in 1 dBm steps |
| | | Model 2083-1310: minimum = -40 to -20 in 1 dBm steps |
| | | Model 2083-1610: minimum = -40 to -20 in 1 dBm steps |
| | | example: {Cl-25} |
| | | Will set the unit's maximum input level to -25 dB. |
| Set Reference Mode | {aaCEx} | Note: The negative sign is assumed if not included, i.e {Cl25} is parsed the same as {Cl-25}. |
| | | The unit will reply with the '>' character if the command is successfully processed. |
| | | where: |
| | | aa = unit address, range = 00 to 31, only used if interface is RS485, otherwise omit. |
| | | E = command code |
| | | x = 0 to set to internal reference, x = 1 to set to external reference, x = 2 to set to auto reference. |
| | | example: {CE2} |
| | | Will set the reference mode to Auto. |
| | | The unit will reply with the '>' character if the command is successfully processed. |

Table 1.3, M&C Commands, continued from page 9...

| Table 1.3 2083-0915 M&C Commands (continued)... | | |
|------------------------------------------------------------|----------------|----------------------------------------------------------------------------------------------------------------------------|
| Command | Syntax* | Description |
| Set Remote Off | {aaCRO} | where: |
| | | aa = unit address, range = 00 to 31, only used if interface is RS485, otherwise omit |
| | | R = command code |
| | | 0, ascii number zero. |
| | | example: {CRO} |
| | | Will disable the unit's serial M&C port. |
| | | The unit will reply with the '>' character if the command is successfully processed. |
| | | <i>(Note: this command only affects the serial M&C port, the ethernet port is always on and will not be affected).</i> |
| Set Remote On | # | Just the ascii pound sign, (0x23) |
| | | Will enable the unit's serial M&C port. |
| | | The unit will reply with the '>' character if the command is successfully processed. |
| | | <i>(Note: this command only affects the serial M&C port, the ethernet port is always on and will not be affected).</i> |

2.0 Installation

2.1 Mechanical - The 2083-1610 consists of one RF/Controller PCB housed in a 1 RU (1 3/4 inch high) by 16 inch deep chassis. A switching, ± 12 , +24, +5 VDC power supply provides power for the assemblies. The 2083-1610 can be secured to a rack using the 4 holes on the front panel. Figure 2.1 shows how the 2083-1610 is assembled.

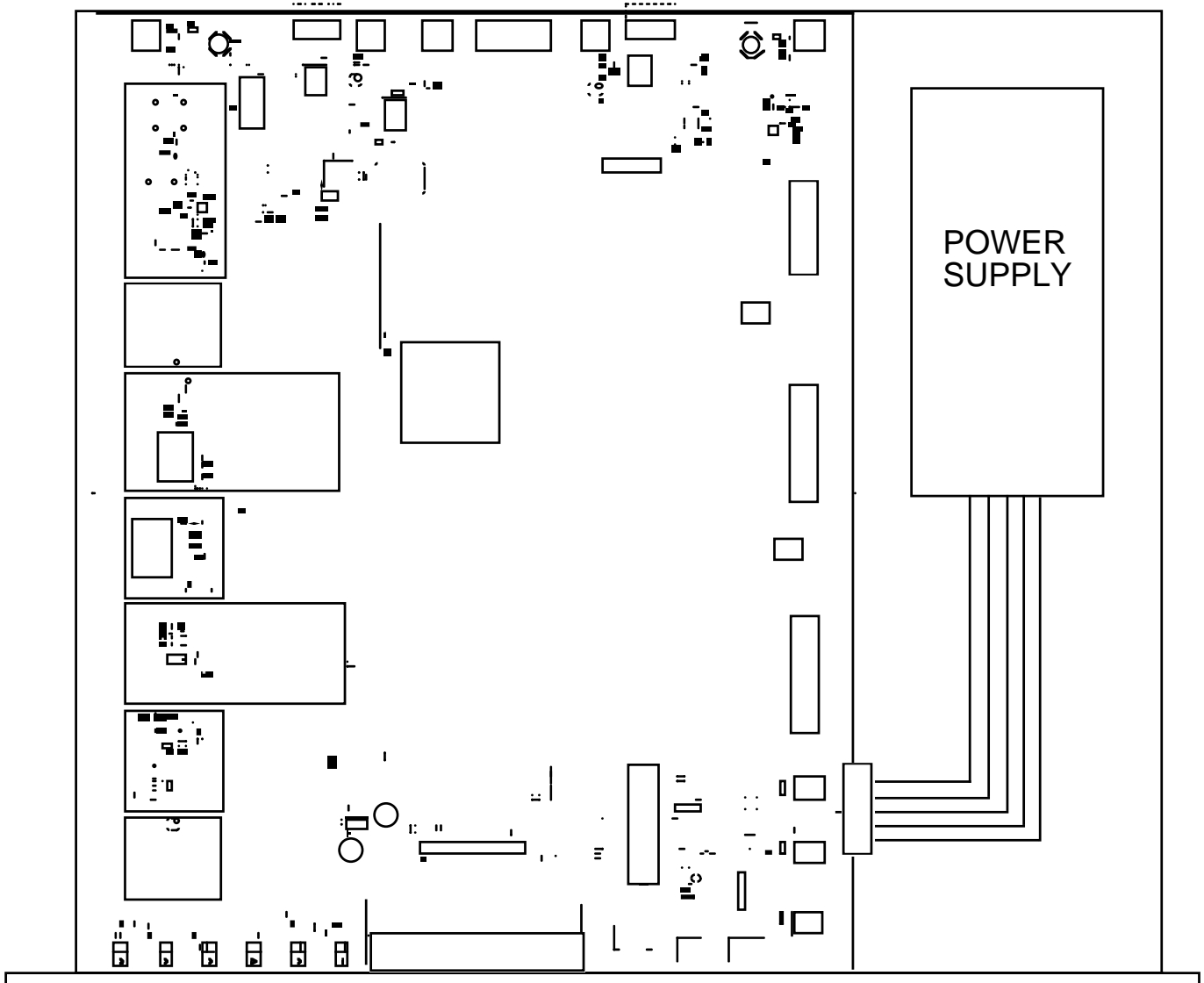

FIGURE 2.1 2083-1610 Mechanical Assembly

2.2 Rear Panel Input/Output Signals - Figure 2.2 shows the input and output connectors on the rear panel.

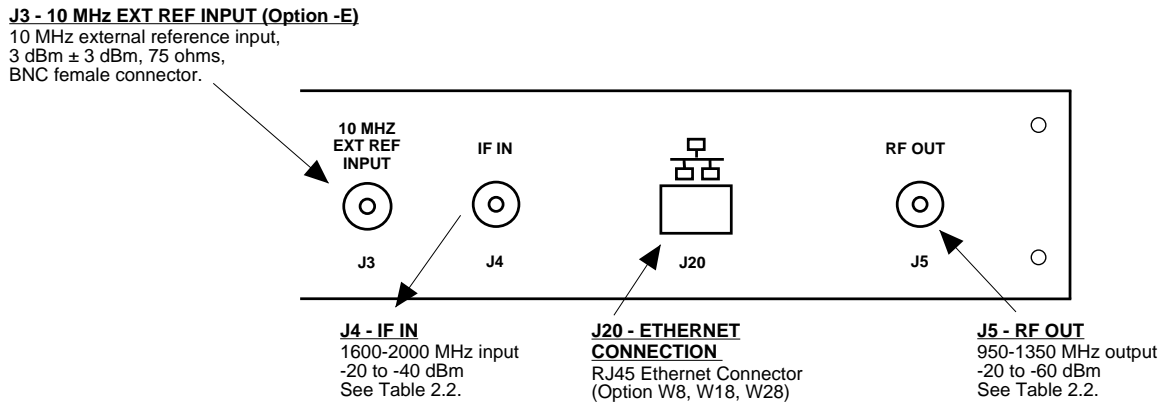

FIGURE 2.2 2083-1610 Rear Panel I/Os

| TABLE 2.1 J10 Pinouts (RS-232C*) | |
|----------------------------------|------------------------------|
| Pin | Function |
| 1 | Not Used |
| 2 | Rx+ (RS-232C) |
| 3 | Tx+ (RS-232C) |
| 4 | Not Used |
| 5 | GND |
| 6 | Alarm Relay: Common |
| 7 | Alarm Relay: Normally Closed |
| 8 | Not Used |
| 9 | Alarm Relay: Normally Open |

*Remote Serial Interface

Interface: DB-9 Male

Protocol: RS-232C, 9600 baud rate, no parity, 8 data bits, 1 start bit, 1 stop bit

| TABLE 2.2 Connector/Impedance Options | | |
|---------------------------------------|---------|---------|
| Option | IF Out | RF In |
| STD | 50Ω BNC | 50Ω BNC |
| -NN | 50Ω N | 50Ω N |
| -SS | 50Ω SMA | 50Ω SMA |

2.3 Front Panel Controls and Indicators - The following are the front panel controls and indicators.

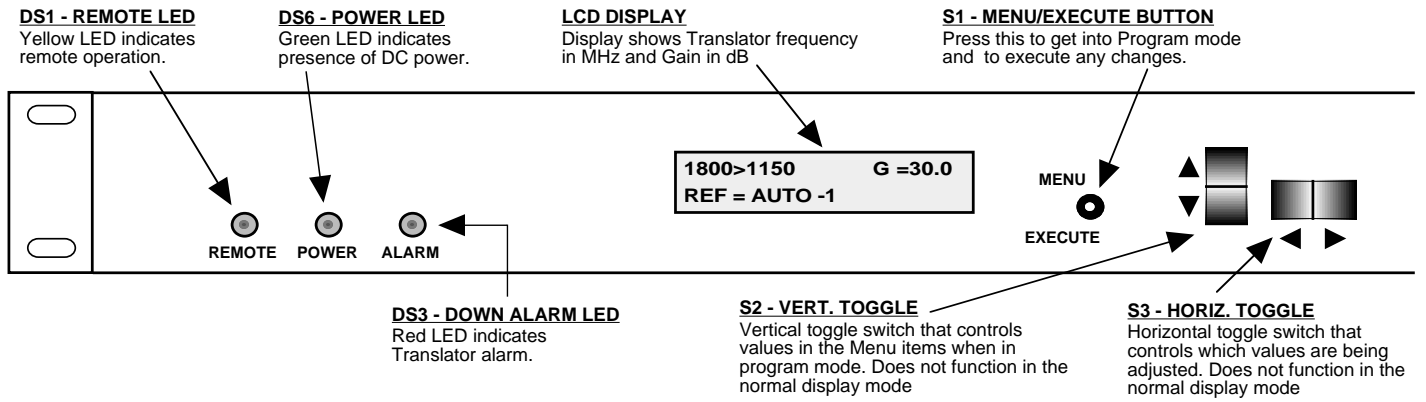

FIGURE 2.3 2083-1610 Front Panel Controls and Indicators

2.4 Operation

2.4.1 Installing and Operating the 2083-1610 Block Translator

1. Connect a -5 dBm to -25 dBm signal to IF IN, J4 (Figure 2.2)
2. Connect the RF OUT, J5, to the external equipment
3. Connect 100-240 \pm 10% VAC, 47 - 63 Hz to AC on the back panel.
4. Set the Max. Input Level for -20 to -40 dBm (See Section 2.5 Menu Settings).
5. Be sure DS6 (green, DC Power) is on and DS (red, Alarm) is off (Figure 2.3).
6. **AC Fuse** - The fuse is a 5 mm X 20 mm, 2 amp slow blow (Type T) and is inserted in the far slot in the drawer below the AC input as shown in Figure 2.4. There is a spare fuse in the near slot.
If a fuse continues to open, the power supply is most likely defective.

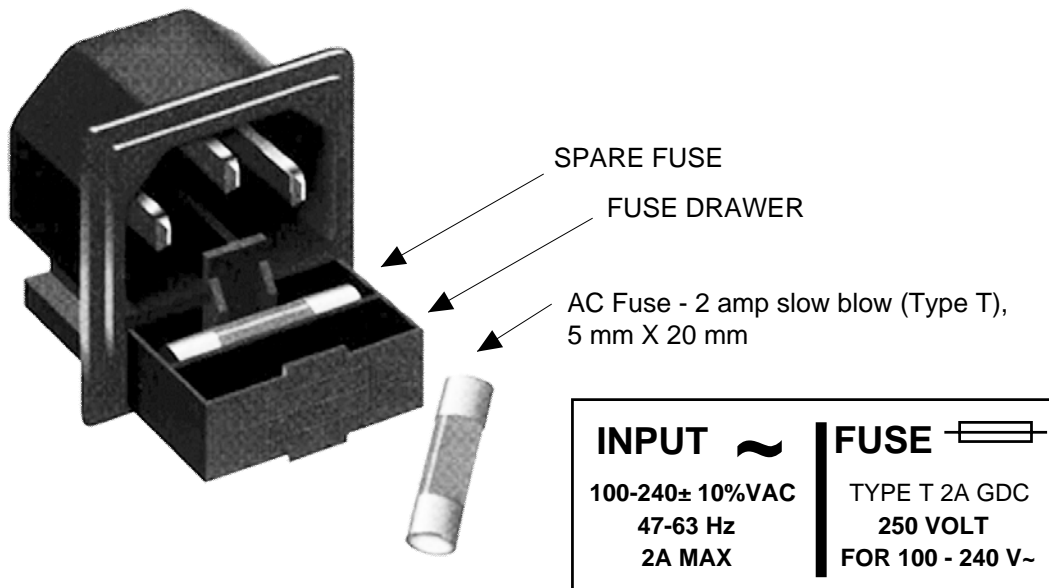

FIGURE 2.4 Fuse Location and Spare Fuse

2.5 Menu Settings

2.5.1 Functions - This section describes operation of the front panel controls. There are three operator switches, the LCD display and alarm indicator LEDs. All functions for the equipment are controlled by these components. The functions are (see Figure 2.5):

Power Up

Normal Display

- Menu 1** Maximum Input Level
- Menu 2** Set Remote
- Menu 3** Select Referene Mode
- Menu 4** Reset Ethernet Settings
- Menu 5** Set Remote mode (option -Q)
- Menu 6** Set RS-485 address (option -Q)

Save Menu When go to “R” or at end

Alarm indications appear on the LEDs (See figure 2.3).

All program changes must start with the operation of the Menu/Execute switch and must also end with the operation of the Menu/Execute switch verified by the “Save Settings?” Menu. If this sequence is not followed, none of the changes will take effect. If programming is initiated and no operator action takes place for approximately 30 seconds (before the final press of the Menu/Execute switch) the display will revert to its previous status and you will need to start over.

2.5.2 Power On Settings

NOTE: THE LAST STATUS OF A UNIT IS RETAINED EVEN WHEN POWER IS REMOVED. WHEN POWER IS RESTORED, THE UNIT WILL RETURN TO IT'S PREVIOUS SETTINGS.

When power is first applied, the LCD display goes through three steps.

1. The LCD goes black to show all segments are functioning.
2. Reading IP Address
2. The software version will be displayed.

READING IP ADDRESS

3. The present frequency and gain of the down converter is shown.

1800>1150 G = -30
REF=AUTO - 1

The unit is now operational and ready for any changes the operator may desire.

2.5.3 Control Switches

1. Menu/Execute - Any change to the programming of the unit must be initiated by pressing the Menu/Execute switch and completed by pressing the Menu/Execute switch.
2. Horizontal Switch - This switch is mounted so its movement is horizontal and moves the cursor left or right.
3. Vertical Switch - This switch is mounted so its movement is vertical and has two functions:
 - a. During frequency, gain changes, the vertical movement will raise or lower the number in the direction of the arrows.
 - b. For other functions such Mute on/off, the vertical switch will alternately turn the function on or off regardless of the direction operated.

2.5.3 Maximum Input Level

To change the MAXIMUM INPUT LEVEL:

Push the Menu/Execute switch to get to the Maximum Input Level (See Figure 2.5 for the sequence of menu options):

```
MAX INPUT LEVEL =      R
-20
```

Pressing the Up/Down switch will change the Maximum Input Level in 1 or 10 dB steps depending on the cursor location:

```
MAX INPUT LEVEL =      R
-20
```

By using the horizontal rocker switch the cursor can be moved left or right. Pressing the Up/Down switch will toggle the display digit selected until you have the desired gain.

```
MAX INPUT LEVEL =      R
-40
```

NOTE: THE MAXIMUM INPUT LEVEL WILL BE CHANGED AS YOU ADJUST THE NUMBERS. HOWEVER, THE VALUE WILL NOT BE STORED UNTIL YOU INDICATE YES IN THE SAVE SETTINGS WINDOW.

When the display indicates the value desired you can push the Menu/Execute switch to get to the next item OR you can scroll to “R” and push the Menu/Execute switch to get to:

```
SAVE SETTINGS?  Y N
```

Selecting **Y** will save the new settings. Selecting **N** will revert to the previous settings.

Pushing the Menu/Execute switch then takes you to this:

```
1800>1150  G = -10
REF=AUTO - 1
```

Figure 2.5 gives the menu items and how to make changes.

2.5.5 Alarm Indications

An alarm condition will occur if any local oscillator phase lock loop (PLL) comes out of lock. The Mute LED will light if you select Mute and the Remote LED will light when you select the Remote mode.

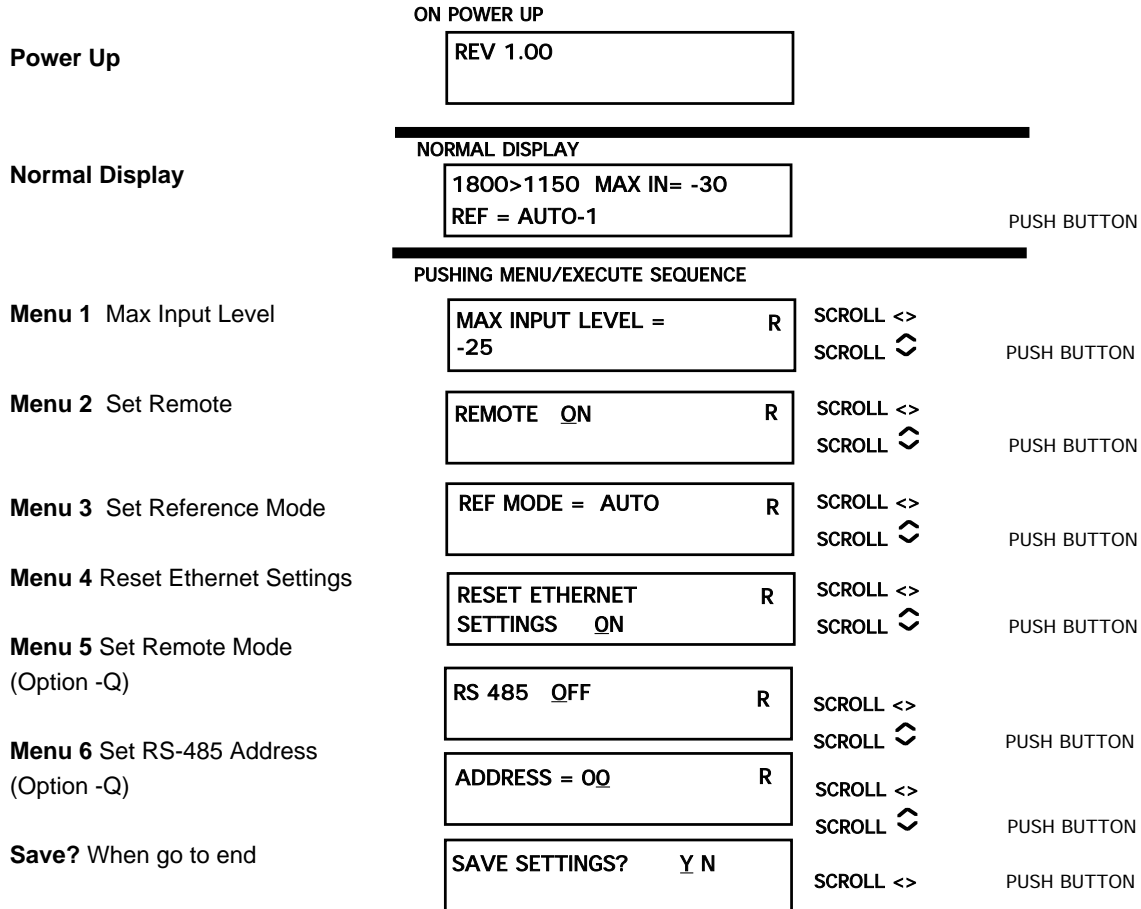

FIGURE 2.5 Menu Display and Sequence

3.0 Environmental Use Information

- A. Rack-Mounting** - To mount this equipment in a rack, please refer to the installation instructions located in the user manual furnished by the manufacturer of your equipment rack.
- B. Mechanical Loading** - Mounting of equipment in a rack should be such that a hazardous condition does not exist due to uneven weight distribution.
- C. Elevated Operating Ambient Temperature** - If installed in a closed or multi-unit rack assembly, the operating ambient temperature of the rack may be greater than room ambient temperature. Therefore, consideration should be given to Tmra (Maximum Recommended Ambient Temperature).
- D. Reduced Air Flow** - Installation of the equipment in a rack should be such that the amount of air flow required for safe operation of the equipment is not compromised. Additional space between units may be required.
- E. Circuit Overloading** - Consideration should be given to the connection of the equipment to the supply circuit and the effect that overloading of circuits could have on over current protection and supply wiring. Appropriate consideration of equipment name plate rating should be used when addressing this concern.
- F. Reliable Earthing** - Reliable earthing of rack-mounted equipment should be maintained. Particular attention should be given to supply connections other than direct connection to the Branch (use of power strips).
- G. Top Cover** - There are no serviceable parts inside the product so, the Top Cover should not be removed. If the Top Cover is removed the ground strap and associated screw **MUST BE REINSTALLED** prior to Top Cover screw replacement. **FAILURE TO DO** this may cause **INGRESS** and/or **EGRESS** emission problems.



6170 Shiloh Road
Alpharetta, Georgia 30005

(770) 886-8005
FAX (770) 886-7964
Toll Free 888-900-5588

WEB www.crosstechnologies.com
E-MAIL info@crosstechnologies.com

Printed in USA