

Instruction Manual

Model 2083-1012 Block Translator

May 2018, Rev. 0

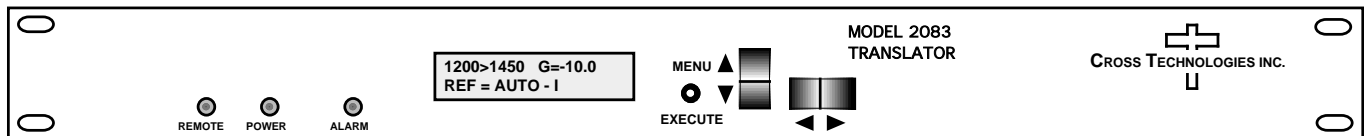

Data, drawings, and other material contained herein are proprietary to Cross Technologies, Inc., but may be reproduced or duplicated without the prior permission of Cross Technologies, Inc. for purposes of operating the equipment.

When ordering parts from Cross Technologies, Inc., be sure to include the equipment model number, equipment serial number, and a description of the part.



6170 Shiloh Road
Alpharetta, Georgia 30005

(770) 886-8005
FAX (770) 886-7964
Toll Free 888-900-5588

WEB www.crosstechnologies.com
E-MAIL info@crosstechnologies.com

INSTRUCTION MANUAL

MODEL 2083-1012 Block Translator

<u>TABLE OF CONTENTS</u>	<u>PAGE</u>
Warranty	2
1.0 General	3
1.1 Equipment Description	3
1.2 Technical Characteristics	4
1.3 Monitor & Control Interface	6
2.0 Installation	11
2.1 Mechanical	11
2.2 Rear I/O's	12
2.3 Front Panel Controls, Indicators	13
2.4 Operation	14
2.5 Menu Settings	15
3.0 Environmental Use Information	19

WARRANTY - The following warranty applies to all Cross Technologies, Inc. products.

All Cross Technologies, Inc. products are warranted against defective materials and workmanship for a period of one year after shipment to customer. Cross Technologies, Inc.'s obligation under this warranty is limited to repairing or, at Cross Technologies, Inc.'s option, replacing parts, subassemblies, or entire assemblies. Cross Technologies, Inc. shall not be liable for any special, indirect, or consequential damages. This warranty does not cover parts or equipment which have been subject to misuse, negligence, or accident by the customer during use. All shipping costs for warranty repairs will be prepaid by the customer. There are not other warranties, express or implied, except as stated herein.



6170 Shiloh Road
Alpharetta, Georgia 30005

(770) 886-8005
FAX (770) 886-7964
Toll Free 888-900-5588

WEB www.crosstechnologies.com
E-MAIL info@crosstechnologies.com

MODEL 2083-1012 Block Translator

1.0 General

1.1 Equipment Description

2083-1012 Block Translator -The 2083-1012 Block Translator converts a 950-1450 MHz block to 1200-1700 MHz block with no spectrum inversion, low group delay and flat frequency response. The 950-1450 MHz input is mixed with synthesized local oscillator (LO) signals, first to 3800 MHz center frequency and finally to the 1200-1700 MHz block output. The gain can be set for 0 to -20 dB in 0.5 ± 0.5 dB increments. Multifunction switches select the Gain and internal or External (Option E) 10 MHz reference which appear on the LCD display and can be adjusted remotely. Front panel LEDs provide indication of DC power (green), PLL alarm (red), and remote operation (yellow). Connectors are BNC female for RF input and output. The unit is powered by a 100-240 $\pm 10\%$ VAC, 47-63 HZ input power supply and housed in a 1 3/4" X 19" X 16" rack mount chassis.

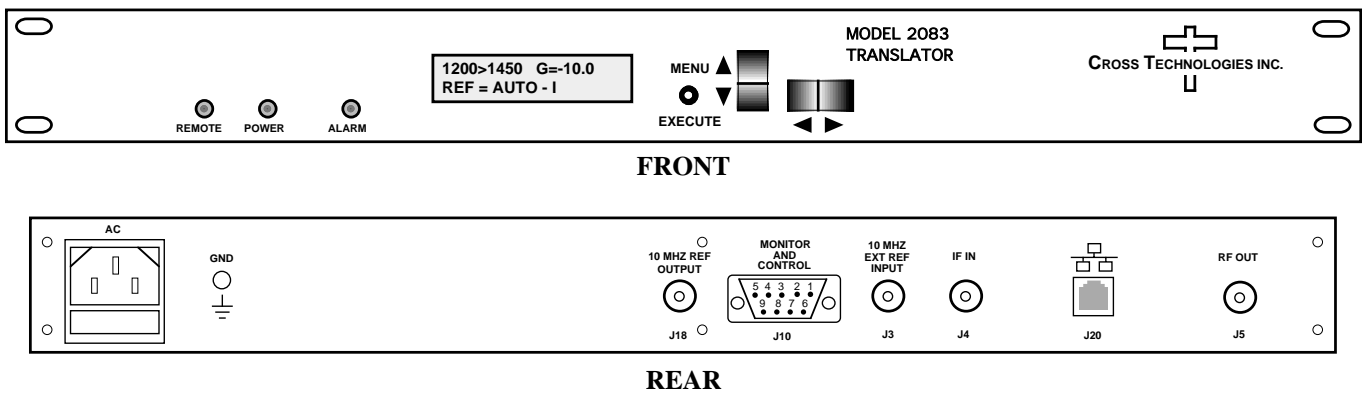

FIGURE 1.1 Model 2083-1012 Front and Rear Panels

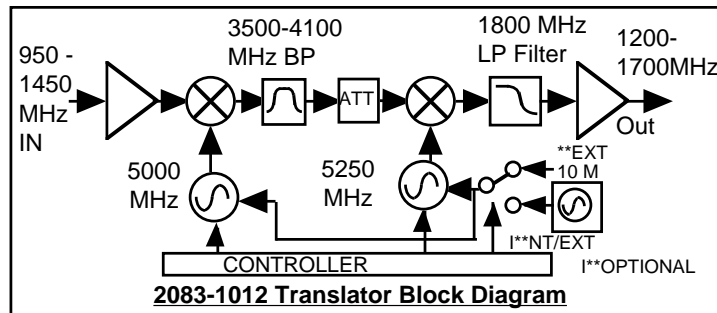

FIGURE 1.2 Model 2083-1012 Translator Block Diagram

1.2 Technical Characteristics

TABLE 1.0 2083-1012 Block Translator Specifications**					
Input Characteristics					
Input Impedance/RL	50Ω/12 dB				
Frequency	950 - 1450 MHz				
Input Composite Level	-25 to -5 dBm				
Input, max. no damage	+15 dBm				
Output Characteristics					
Impedance/RL	50Ω / 12 dB				
Frequency	1200 -1700 MHz				
Output Composite Level	-25 to -5 dBm				
Output 1 dB Compression	+5 dBm, at maximum gain				
Channel Characteristics					
Gain	0 to -20 dB, ±1 dB, selectable in 0.5± 0.5 dB steps				
Frequency Response	± 1.5 dB, 500 MHz bandwidth; ± 0.5 dB, any 40 MHz increment				
Spurious, Inband	< -50 dBC in band, signal dependent and signal independent; -5 dBm out; See NOTE 1				
Spurious, Out of Band	< -30 dBC, 0.5- 1.19 GHz and 1.71-2.2 GHz; -5 dBm out; See NOTE 1				
Frequency Sense	Non-inverting				
	*NOTE 1: dBC is relative to the COMPOSITE Output Level				
Synthesizer Characteristics					
Translation; Accuracy	1ppm; Option -H, ±0.01 ppm				
Reference	10 MHz Internal; Option -E, Internal / External Selection				
Frequency Step	None, fixed frequency				
Phase Noise @ Frequency	100 MHz	1kHz	10kHz	100kHz	1MHz
dBC/Hz	-70	-70	-80	-90	-100
Controls, Indicators					
Fc Translation	Direct readout LCD; manual or remote selection				
Gain (MGC)	Direct readout LCD; manual or remote selection				
External Ref. (Option -E)	Direct readout LCD; manual or remote selection				
Power, Alarm; Remote	Green LED; Red LED; Yellow LED				
Remote	RS232C, 9600 Baud; RS485, Ethernet Options				
Other					
RF In/RF Out Connector	BNC (female)				
10 MHz Out Connector	BNC (female), 75Ω, works with 50 or 75 ohms				
Alarm/Remote Connector	DB9 (female); No or NC contact closure on Alarm				
Size	19 inch Standard Chassis 1.75" high x 16.0" deep				
Power	100-240 (±10%) VAC, 47- 63 Hz, 30 watts maximum				
Available Options (see page 5...)					
**+10°C to +40°C; Specifications subject to change without notice.					
Cross Technologies, Inc. 2018					

1.2 Technical Characteristics, continued...

Available Options (2083-1012 Block Translator)	
E -	External 10 MHz Input and Output
H -	High Stability (± 0.01) Internal Reference
Communication Interface / Standard RS232	
Q -	RS485 Remote Interface
W8 -	Ethernet; with Web Browser
W18 -	Ethernet; with Web Browser & SNMP
W28 -	Ethernet; with TCP/IP, Telnet®
Connector /Impedance	
Std -	50 Ω BNC (RF IN), 50 Ω BNC (RF OUT)
NN -	50 Ω N (RF In), 50 Ω N (RF Out)
SS -	50 Ω SMA (RF In), 50 Ω SMA (RF Out)
Contact Cross Technologies for other options.	

1.3 Monitor and Control Interface

A) Remote Serial Interface

Protocol: RS-232C, 9600 baud rate, no parity, 8 data bits, 1 start bit, and 1 stop bit.
(RS-232C, RS-422, or **RS-485 - option -Q**)

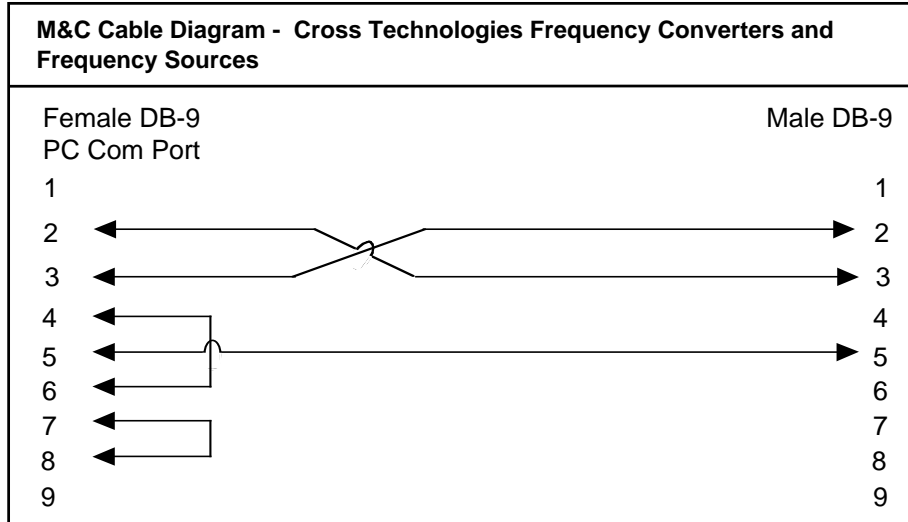

Connector: Rear panel, DB-9 male

J10 Pinouts (RS-232C/422/485)	
Pin	Function
1	Rx-
2	Rx+ (RS-232C)
3	Tx+ (RS-232C)
4	Tx-
5	GND
6	Alarm Relay: Common
7	Alarm Relay: Normally Open
8	Not Used
9	Alarm Relay: Normally Closed

B) Status Request/Inquiries -

Table 1.0 lists the Status Request/Inquiries for the 2083-1012, and briefly describes them.

General Command Format - The general command format is {aaCND...}, where:

{ = start byte

aa = address (**RS-485 only - option -Q**)

C = 1 character, either C (command) or S (status)

N = 1 character command or status request

D = 1 character or more of data (depends on command)

} = stop byte

* PLEASE NOTE: The two character {aa}(00-31) prefix, in the table below, should be used ONLY when RS-485, (OPTION-Q), is selected.

TABLE 1.2 2083-1012 Status Request/Inquiries		
Command	Syntax*	Description
Gain Inquiry	{aaSG}	returns: {aaSGxxxx}
		where:
		aa = unit address, range = 00 to 31, only used if interface is RS485, otherwise omit
		G = command code
		xxxx = gain in dB (decimal point omitted)
		The unit will append the '>' character if the command is successfully processed.
Reference Mode Inquiry	{aaSE}	returns: {aaSEx}
		where:
		aa = unit address, range = 00 to 31, only used if interface is RS485, otherwise omit
		E = command code
		x = 0 if reference mode is internal, x = 1 if external,
		x = 2 if auto
		The unit will append the '>' character if the command is successfully processed.
Reference Status Inquiry	{aaSB}	returns: {aaSBx}
		where:
		aa = unit address, range = 00 to 31, only used if interface is RS485, otherwise omit
		B = command code
		x = 1 if the unit is using the external reference, x = 0 if the unit is using the internal reference
		note: this inquiry is useful if the reference mode is auto and the user wants to know if the unit has switched to the internal reference.
		The unit will append the '>' character if the command is successfully processed.

Table 1.2, Status Request/Inquiries continued from page 7...

TABLE 1.2 2083-1012 Status Request/Inquiries		
Command	Syntax*	Description
Alarm Inquiry	{aaSA}	returns: {aaSAx}
		where:
		aa = unit address, range = 00 to 31, only used if interface is RS485, otherwise omit
		A = command code
		x = 0 if alarm is off, x = 1 if alarm is on.
		The unit will append the '>' character if the command is successfully processed.
Product/Model Info Inquiry	{aaSV}	returns {aaSV2083-xxxx yyyy ver5.xx}
		where 2083-xxxx = product model
		yyyy = list of options, if any
		"ver" = separates model & options from firmware version
		5.xx = firmware version

C) Commands - Table 1.0 lists the M&C Commands for the 2083-1012, and briefly describes them. After a command is sent the 2083-1012 sends a return “>” indicating the command has been received and executed.

General Command Format - The general command format is {aaCND...}, where:

- { = start byte
- aa = address (**RS-485 only - option -Q**)
- C = 1 character, either C (command) or S (status)
- N = 1 character command or status request
- D = 1 character or more of data (depends on command)
- } = stop byte

* PLEASE NOTE: The two character {aa}(00-31) prefix, in the table below, should be used ONLY when RS-485, (OPTION-Q), is selected.

Table 1.3 2083-1012 M&C Commands		
Command Function	Syntax*	Command Description
Set Gain	{aaCGxxxx}	where:
		aa = unit address, range = 00 to 31,
		only used if interface is RS485, otherwise omit
		G = command code
		xxxx = gain in 0.5 dB steps, omit the decimal point
		Range: = -200 to 0 in 0.5 dB steps
		example: {CG-155}
		Will set the unit's gain to -15.5 dB.
		Note: The negative sign is assumed if not included, i.e.
		{CG155} is parsed the same as {CG-155}.
		The unit will reply with the '>' character if the command
		is successfully processed.
Set Reference Mode	{aaCEx}	where:
		aa = unit address, range = 00 to 31, only used if interface
		is RS485, otherwise omit.
		E = command code
		x = 0 to set to internal reference, x = 1 to set to
		external reference, x = 2 to set to auto reference.
		example: {CE2}
		Will set the reference mode to Auto.
		The unit will reply with the '>' character if the
		command is successfully processed.

Table 1.3, M&C Commands continued from page 9...

Table 1.3 2083-1012 M&C Commands (continued)...		
Command	Syntax*	Description
Set Remote Off	{aaCRO}	where:
		aa = unit address, range = 00 to 31, only used if interface is RS485, otherwise omit
		R = command code
		0, ascii number zero.
		example: {CRO}
		Will disable the unit's serial M&C port.
		The unit will reply with the '>' character if the command is successfully processed.
		<i>(Note: this command only affects the serial M&C port, the ethernet port is always on and will not be affected).</i>
Set Remote On	#	Just the ascii pound sign, (0x23)
		Will enable the unit's serial M&C port.
		The unit will reply with the '>' character if the command is successfully processed.
		<i>(Note: this command only affects the serial M&C port, the ethernet port is always on and will not be affected).</i>

2.0 Installation

2.1 Mechanical - The 2083-1012 consists of one RF/Controller PCB housed in a 1 RU (1 3/4 inch high) by 16 inch deep chassis. A switching, ± 12 , +24, +5 VDC power supply provides power for the assemblies. The 2083-1012 can be secured to a rack using the 4 holes on the front panel. Figure 2.1 shows how the 2083-1012 is assembled.

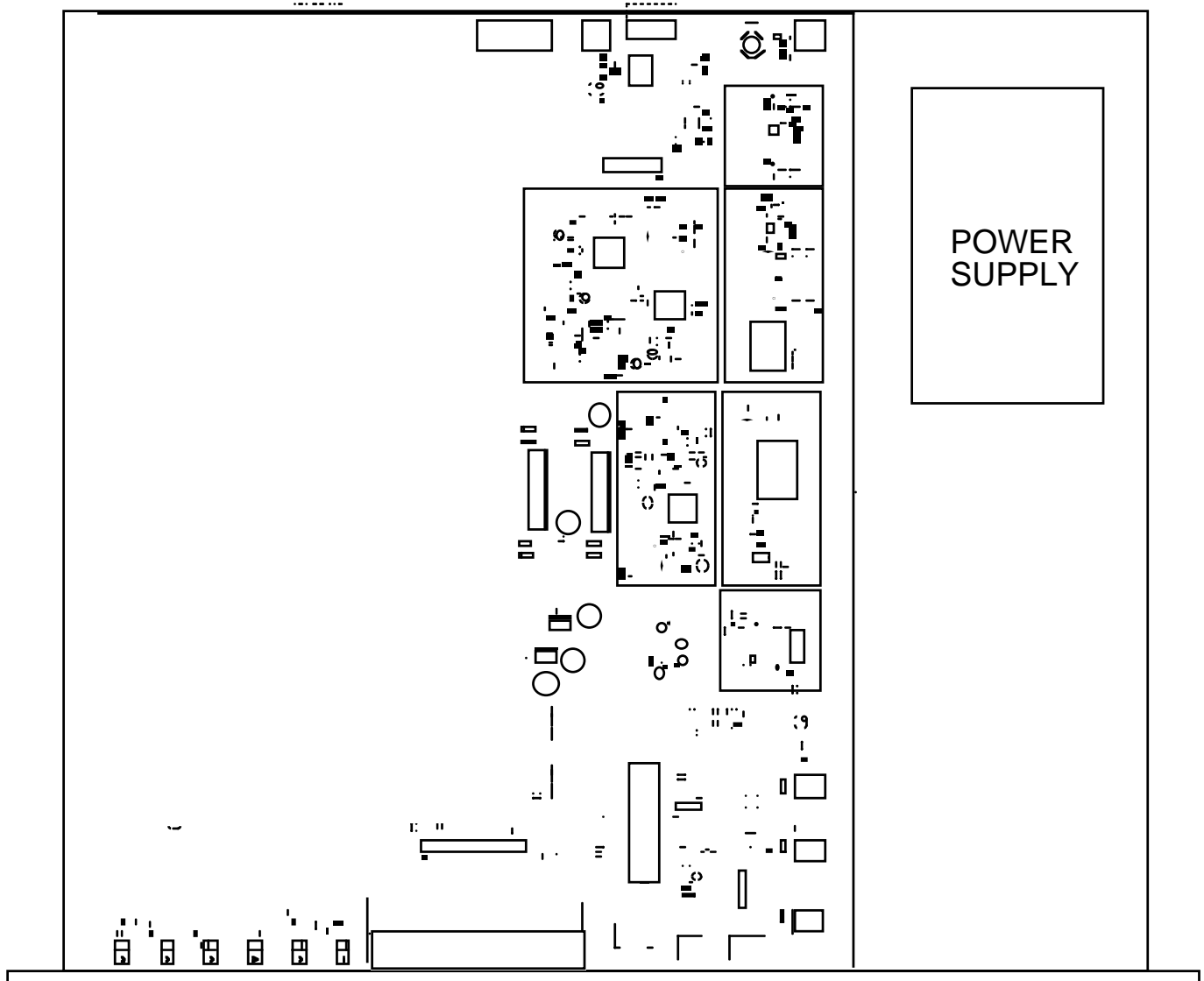

FIGURE 2.1 2083-1012 Mechanical Assembly

2.2 Rear Panel Input/Output Signals - Figure 2.2 shows the input and output connectors on the rear panel.

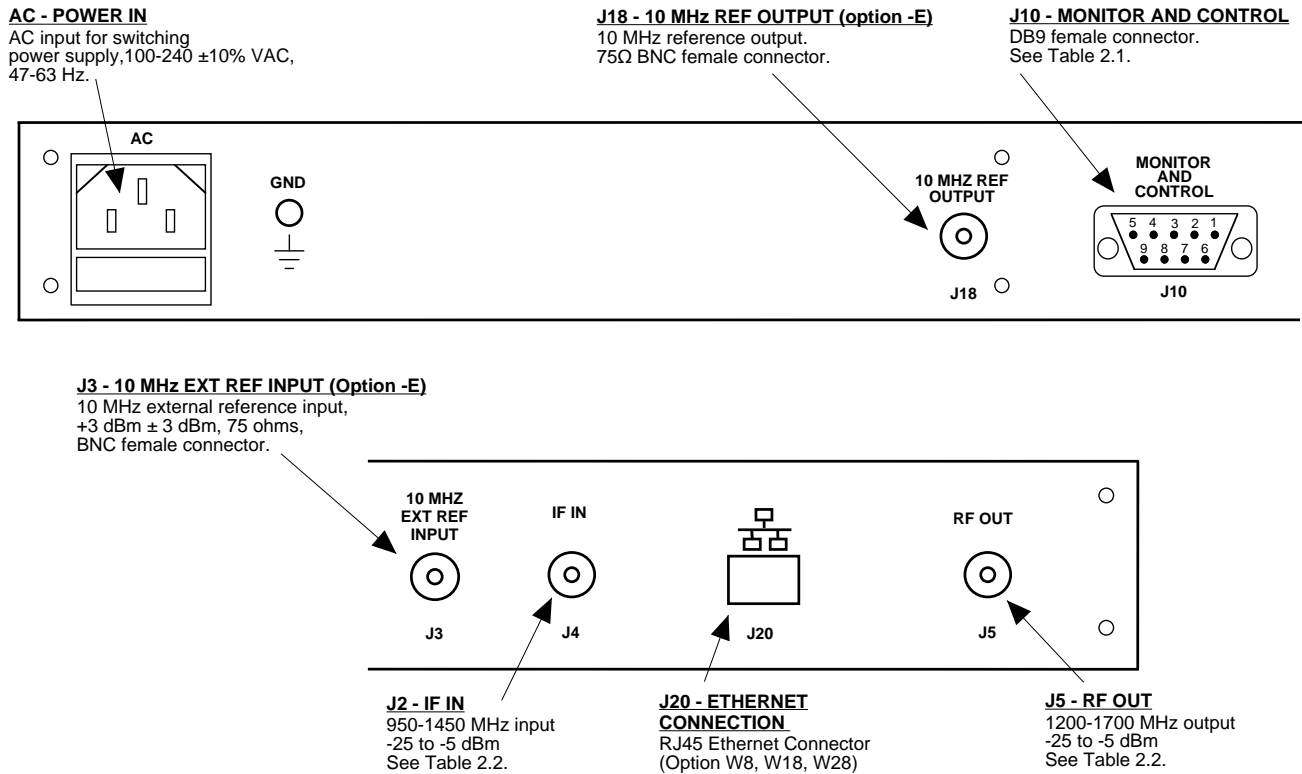

FIGURE 2.2 2083-1012 Rear Panel I/Os

TABLE 2.1 J10 Pinouts (RS-232C*)	
Pin	Function
1	Not Used
2	Rx+ (RS-232C)
3	Tx+ (RS-232C)
4	Not Used
5	GND
6	Alarm Relay: Common
7	Alarm Relay: Normally Closed
8	Not Used
9	Alarm Relay: Normally Open

*Remote Serial Interface

Interface: DB-9 Male

Protocol: RS-232C, 9600 baud rate, no parity, 8 data bits, 1 start bit, 1 stop bit

TABLE 2.2 Connector/Impedance Options		
Option	IF IN	RF Out
STD	BNC, 50 Ω	BNC, 50 Ω
-B	BNC, 75 Ω	BNC, 75 Ω
-NN	N for input	N for output
-SS	SMA, 50 Ω	SMA, 50 Ω

2.3 Front Panel Controls and Indicators - The following are the front panel controls and indicators.

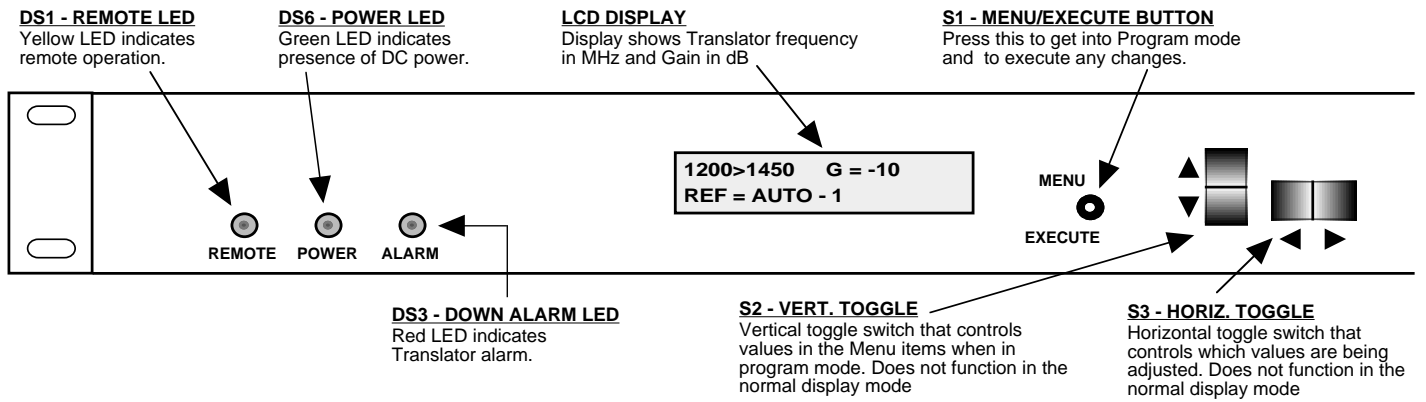

FIGURE 2.3 2083-1012 Front Panel Controls and Indicators

2.4 Operation

2.4.1 Installing and Operating the 2083-1012 Block Translator

1. Connect a -25 dBm to -5 dBm signal to IF IN, J4 (Figure 2.2)
2. Connect the RF OUT, J5, to the external equipment
3. Connect 100-240 \pm 10% VAC, 47 - 63 Hz to AC on the back panel.
4. Set the gain for 0 to -20 dBm (See Section 2.5 Menu Settings).
5. Be sure DS6 (green, DC Power) is on and DS (red, Alarm) is off (Figure 2.3).
6. **AC Fuse** - The fuse is a 5 mm X 20 mm, 2 amp slow blow (Type T) and is inserted in the far slot in the drawer below the AC input as shown in Figure 2.4. There is a spare fuse in the near slot.
If a fuse continues to open, the power supply is most likely defective.

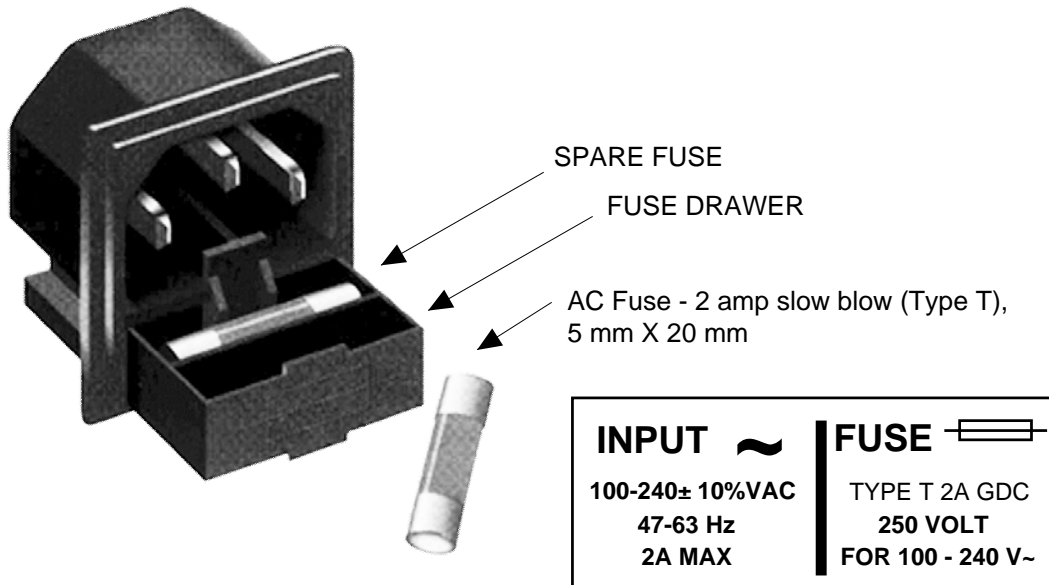

FIGURE 2.4 Fuse Location and Spare Fuse

2.5 Menu Settings

2.5.1 Functions - This section describes operation of the front panel controls. There are three operator switches, the LCD display and alarm indicator LEDs. All functions for the equipment are controlled by these components. The functions are (see Figure 2.5):

Power Up

Normal Display

- Menu 1** Gain (0 to -20, +5 dB Steps)
- Menu 2** Set Unit to Remote Operation
- Menu 3** Select External 10 MHz Ref (option -E)
- Menu 4** Set Remote mode (option -Q)
- Menu 5** Set RS-485 address (option -Q)

Save Menu When go to “R” or at end

Alarm indications appear on the LEDs (See figure 2.3).

All program changes must start with the operation of the Menu/Execute switch and must also end with the operation of the Menu/Execute switch verified by the “Save Settings?” Menu. If this sequence is not followed, none of the changes will take effect. If programming is initiated and no operator action takes place for approximately 30 seconds (before the final press of the Menu/Execute switch) the display will revert to its previous status and you will need to start over.

2.5.2 Power On Settings

NOTE: THE LAST STATUS OF A UNIT IS RETAINED EVEN WHEN POWER IS REMOVED. WHEN POWER IS RESTORED, THE UNIT WILL RETURN TO IT'S PREVIOUS SETTINGS.

When power is first applied, the LCD display goes through three steps.

1. The LCD goes black to show all segments are functioning.
2. The software version will be displayed.



REV 1.00

3. The present frequency and gain of the down converter is shown.

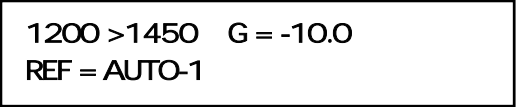

1200 >1450 G = -10.0
REF = AUTO-1

The unit is now operational and ready for any changes the operator may desire.

2.5.3 Control Switches

1. Menu/Execute - Any change to the programming of the unit must be initiated by pressing the Menu/Execute switch and completed by pressing the Menu/Execute switch.
2. Horizontal Switch - This switch is mounted so its movement is horizontal and moves the cursor left or right.
3. Vertical Switch - This switch is mounted so its movement is vertical and has two functions:
 - a. During frequency, gain changes, the vertical movement will raise or lower the number in the direction of the arrows.
 - b. For other functions such Mute on/off, the vertical switch will alternately turn the function on or off regardless of the direction operated.

2.5.4 Gain Changes

When you get to this menu note that the gain changes will be made as you make them but if you do not wish to save the changes you have made, scroll to “**R**” and push the Menu/Execute switch and select “**NO**” in the “**SAVE SETTINGS?**” window or **do not press the Menu/Execute switch**; simply do nothing for approximately 12 seconds, and the system will return to the normal operating mode.

To change the TRANSLATOR GAIN:

Push the Menu/Execute switch to get to the gain setting (See Figure 2.5 for the sequence of menu options):

G = - <u>2</u> 0.0	R
--------------------	---

Pressing the Up/Down switch will change the gain in .5, 1 or 10 dB steps depending on the cursor location:

G = - <u>1</u> 5.0	R
--------------------	---

By using the horizontal rocker switch the cursor can be moved left or right. Pressing the Up/Down switch will toggle the display digit selected until you have the desired gain.

G = -1 <u>5</u> .0	R
--------------------	---

NOTE: THE GAIN WILL BE CHANGED AS YOU ADJUST THE NUMBERS. HOWEVER, THE VALUE WILL NOT BE STORED UNTIL YOU INDICATE YES IN THE SAVE SETTINGS WINDOW.

When the display indicates the value desired you can push the Menu/Execute switch to get to the next item OR you can scroll to “**R**” and push the Menu/Execute switch to get to:

SAVE SETTINGS? <u>Y</u> N

Selecting **Y** will save the new settings. Selecting **N** will revert to the previous settings.

Pushing the Menu/Execute switch then takes you to this:

1200 >1450 G = -10.0
REF = AUTO-1

Figure 2.5 gives the menu items and how to make changes.

2.5.5 Alarm Indications

An alarm condition will occur if any local oscillator phase lock loop (PLL) comes out of lock. The Remote LED will light when you select the Remote mode.

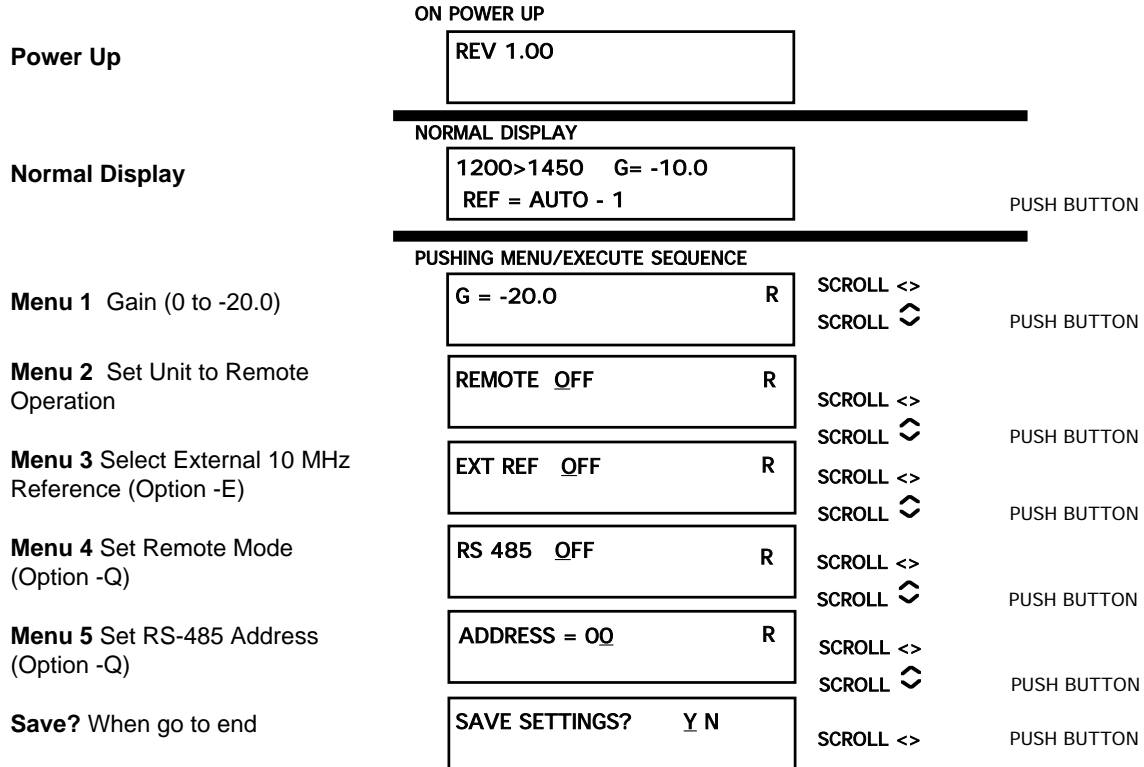

FIGURE 2.5 Menu Display and Sequence

3.0 Environmental Use Information

- A. **Rack-Mounting** - To mount this equipment in a rack, please refer to the installation instructions located in the user manual furnished by the manufacturer of your equipment rack.
- B. **Mechanical Loading** - Mounting of equipment in a rack should be such that a hazardous condition does not exist due to uneven weight distribution.
- C. **Elevated Operating Ambient Temperature** - If installed in a closed or multi-unit rack assembly, the operating ambient temperature of the rack may be greater than room ambient temperature. Therefore, consideration should be given to Tmra (Maximum Recommended Ambient Temperature).
- D. **Reduced Air Flow** - Installation of the equipment in a rack should be such that the amount of air flow required for safe operation of the equipment is not compromised. Additional space between units may be required.
- E. **Circuit Overloading** - Consideration should be given to the connection of the equipment to the supply circuit and the effect that overloading of circuits could have on over current protection and supply wiring. Appropriate consideration of equipment name plate rating should be used when addressing this concern.
- F. **Reliable Earthing** - Reliable earthing of rack-mounted equipment should be maintained. Particular attention should be given to supply connections other than direct connection to the Branch (use of power strips).
- G. **Top Cover** - There are no serviceable parts inside the product so, the Top Cover should not be removed. If the Top Cover is removed the ground strap and associated screw **MUST BE REINSTALLED** prior to Top Cover screw replacement. **FAILURE TO DO** this may cause **INGRESS** and/or **EGRESS** emission problems.



6170 Shiloh Road
Alpharetta, Georgia 30005

(770) 886-8005
FAX (770) 886-7964
Toll Free 888-900-5588

WEB www.crosstechnologies.com
E-MAIL info@crosstechnologies.com

Printed in USA