

# Instruction Manual

# Model 2017-2717-140 Up/Downconverter

February 2018, Rev. 0

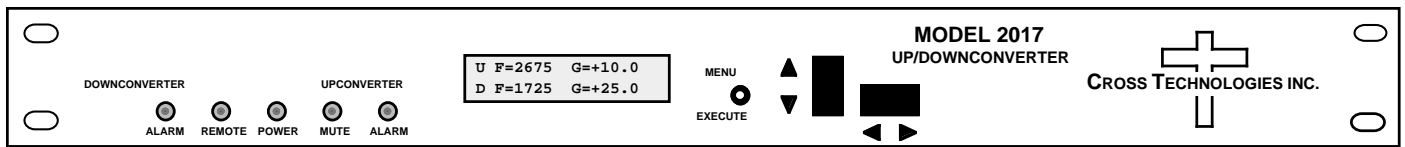

Data, drawings, and other material contained herein are proprietary to Cross Technologies, Inc., but may be reproduced or duplicated without the prior permission of Cross Technologies, Inc. for purposes of operating the equipment.

When ordering parts from Cross Technologies, Inc., be sure to include the equipment model number, equipment serial number, and a description of the part.



6170 Shiloh Road  
Alpharetta, Georgia 30005

(770) 886-8005  
FAX (770) 886-7964  
Toll Free 888-900-5588

WEB [www.crosstechnologies.com](http://www.crosstechnologies.com)  
E-MAIL [info@crosstechnologies.com](mailto:info@crosstechnologies.com)

# INSTRUCTION MANUAL

## MODEL 2017-2717-140 Up/Downconverter

<b><u>TABLE OF CONTENTS</u></b>	<b><u>PAGE</u></b>
<b>Warranty</b>	<b>2</b>
<b>1.0 General</b>	<b>3</b>
1.1 Equipment Description	<b>3</b>
1.2 Technical Characteristics	<b>4</b>
1.3 Monitor & Control Interface	<b>6</b>
<b>2.0 Installation</b>	<b>8</b>
2.1 Mechanical	<b>8</b>
2.2 Rear I/O's	<b>9</b>
2.3 Front Panel Controls, Indicators	<b>10</b>
2.4 Operation	<b>11</b>
2.5 Menu Settings	<b>12</b>

**WARRANTY** - The following warranty applies to all Cross Technologies, Inc. products.

All Cross Technologies, Inc. products are warranted against defective materials and workmanship for a period of one year after shipment to customer. Cross Technologies, Inc.'s obligation under this warranty is limited to repairing or, at Cross Technologies, Inc.'s option, replacing parts, subassemblies, or entire assemblies. Cross Technologies, Inc. shall not be liable for any special, indirect, or consequential damages. This warranty does not cover parts or equipment which have been subject to misuse, negligence, or accident by the customer during use. All shipping costs for warranty repairs will be prepaid by the customer. There are not other warranties, express or implied, except as stated herein.



6170 Shiloh Rd.  
Alpharetta, GA 30005

(770) 886-8005  
FAX (770) 886-7964  
Toll Free 888-900-5588

WEB [www.crosstechnologies.com](http://www.crosstechnologies.com)  
E-MAIL [info@crosstechnologies.com](mailto:info@crosstechnologies.com)

# MODEL 2017-2717-140 Up/Downconverter

## 1.0 General

### 1.1 Equipment Description

The 2017-2717-140 S, L-band Up/Downconverter converts  $140 \pm 20$  MHz to 2.0-2.7 GHz (Up) and 0.95-1.75 GHz to  $140 \pm 20$  MHz (Down) in 1 MHz steps (100 or 125 kHz steps optional). Multi-function switches select the frequency, gain (upconverter -10 to +30 dB; downconverter 0 to +50 dB), and other parameters. Front panel LEDs provide indication of DC power (green), PLL alarm (red), remote operation (yellow), and Upconverter mute (yellow). Remote operation allows selection of frequency, gain and external 10 MHz reference (option E). Gain settings appear on the LCD display. Connectors are BNC female for the IF, RF (SMA and N optional) and optional external reference input and output (option E). A high stability ( $\pm 0.01$  ppm) option (H) is also available. It is powered by a 100-240  $\pm 10\%$  VAC power supply and housed in a 1.75" X 19" X 16" 1RU chassis.

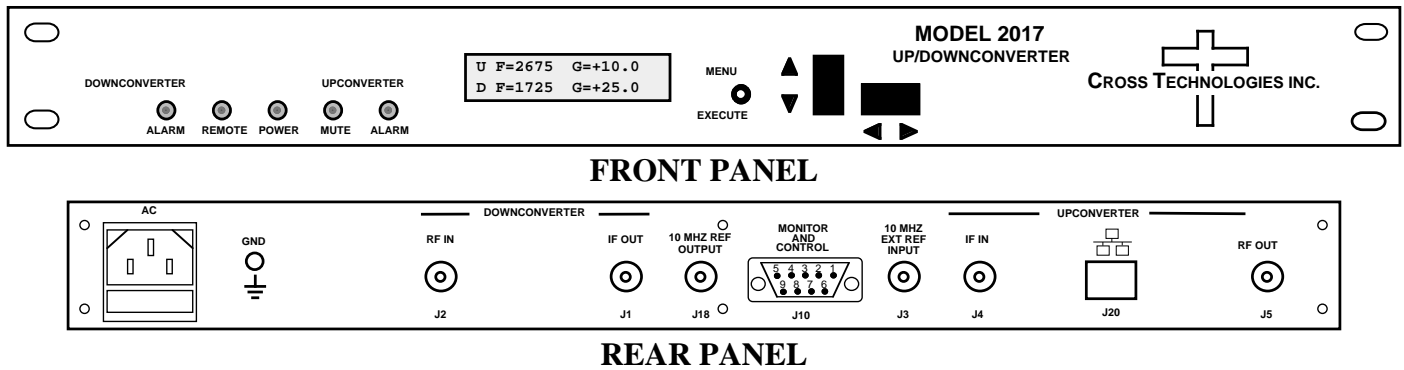

Figure 1.1 Model 2017-2717-140 Front and Rear Panels

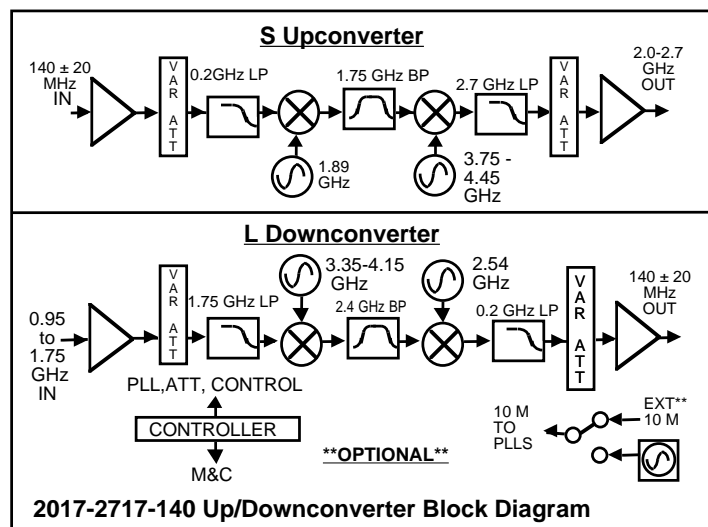

Figure 1.2 Model 2017-2717-140 Up/Downconverter Block Diagram

## 1.2 Technical Characteristics

**TABLE 1.0 2017-2717-140 Up/Downconverter Specifications\***

### -----UPCONVERTER-----

#### Input Characteristics

Impedance/Return Loss	50 Ω /14 dB
Frequency	140 ± 20 MHz
Noise Figure, Maximum	20 dB @ max. gain
Input Level Range	-40 to -10 dBm

#### Output Characteristics

Impedance/Return Loss	50 Ω/14 dB
Frequency (GHz)	2.0 to 2.7 GHz
Output Level Range	-20 to 0 dBm
1 dB comp. maximum gain	+5 dBm
Mute @ 0 dBm out	>60 dB

#### Channel Characteristics

Gain, max. at Fc	+30 ±3 dB
Gain range, 1 ±1 dB steps	+30 dB to -10 dB
Image Rejection	N/A
Spurious, Inband, sig. rel.	<-50 dBC 0 dBm
Spurious, Inband, sig. ind.	<-50 dBC Gmax.
Spurious, Out of Band	<-50 dBC Gmax
Intermod - 2 Carriers	<-50 dBC Gmax
Frequency Resp. Band	±2 dB
Frequency Resp. 36,40 MHz	± 0.5 dB, ±1.0 dB
Frequency Sense	Non-inverting

### -----DOWNCONVERTER-----

#### Input Characteristics (L)

Impedance/Return Loss	50 Ω /14 dB
Frequency	0.95 to 1.75 GHz
Noise Figure (max)	15 dB @ max gain
Input Level	-70 to -20 dBm

#### Output Characteristics (L)

Impedance/Return Loss	50 Ω/14 dB
Frequency	140 ± 20 MHz
Output level/max linear	-30 to -10 dBm
Output 1 dB compression	-5 dBm
Mute @ 0 dBm Out	N/A

#### Channel Characteristics

Gain, max. at Fc	+50 ±3 dB
Gain range, 1 ±1 dB steps	+50 to 0 dB
Image Rejection	> 50 dB, min.
Spurious, Inband, sig. rel.	<-50 dBC 0 dBm
Spurious, Inband, sig. ind.	<-50 dBC Gmax.
Spurious, Out of Band	<-50 dBC Gmax
Intermod - 2 Carriers	<-50 dBC Gmax
Frequency Resp. Band	±2 dB
Frequency Resp. 40 MHz	±0.5 dB, ± 1.0 dB
Frequency Sense	Inverting/Non-inverting

### -----UP AND DOWNCONVERTER-----

#### Synthesizer Characteristics

Frequency Accuracy	± 1.0 ppm internal reference (±0.01 ppm, <b>option -H</b> )
Frequency Step	1 MHz, others optional
10 MHz In/Out Level	3 dBm ± 3 dB, 75 ohms (Option E)

Phase Noise @ Freq	100 Hz	1kHz	10kHz	100kHz	1MHz
dBc/Hz	-70	-70	-80	-95	-110

#### Controls, Indicators

Gain Selection	Direct readout LCD; pushbutton switches or remote selection
Power	Green LED
Alarm; Remote	Red LED, Yellow LED
Remote	RS232C, 9600 baud; (RS485, option Q, Ethernet, optional)

#### Other

RF/IF Connector	BNC (female) 50Ω RF, 75Ω IF
10 MHz Connectors	BNC (female), 75Ω connector works with 50 or 75 ohms
Alarm/Remote Connector	DB9 (female) - NO or NC contact closure on Alarm
Size	19 inch, 1RU standard chassis 1.75"high X 16.0"deep
Power	100-240 ±10% VAC, 47-63 Hz, 45 watts maximum

*Continued on next page...*

**TABLE 1.0 2017-2717-140 Up/Downconverter Specifications...** Continued from page 4

**Available Options:**

E	External 10 MHz Reference input & output
H	High Stability ( $\pm 0.01$ ppm) Internal Reference
W78	RF/RF Monitor Ports (Front)
W31	External Temp 0C to +50C
X or X1	125 kHz or 100 kHz step size

**Remote & M&C Interfaces:**

Q	RS485 Remote Interface
W8	Ethernet with Web Browser
W18	Ethernet with Web Browser & SNMP
W28	Ethernet with TCP/IP, <i>Telnet</i> <sup>®</sup>

**Connectors/Impedance Interfaces:**

-D	50 $\Omega$ , BNC (RF), 50 $\Omega$ BNC (IF)
-N	50 $\Omega$ , N-Type (RF), 75 $\Omega$ BNC (IF)
-M	50 $\Omega$ , N-Type (RF), 50 $\Omega$ BNC (IF)
-S	50 $\Omega$ , SMA (RF), 50 $\Omega$ BNC (IF)
-SS	50 $\Omega$ , SMA (RF), 50 $\Omega$ SMA (IF)

Contact Cross for other available options

---

\*+10°C to +40°C; Specifications subject to change without notice

## 1.3 Monitor and Control Interface

### A) Remote serial interface

**Protocol:** RS-232C, 9600 baud rate, no parity, 8 data bits, 1 start bit, and 1 stop bit.  
(RS-232C, RS-422, or RS-485 - **option -Q**)

**Connector:** Rear panel, DB-9 male

J10 Pinouts (RS-232C/422/485)	
Pin	Function
1	Rx-
2	Rx+ (RS-232C)
3	Tx+ (RS-232C)
4	Tx-
5	GND
6	Alarm Relay: Common
7	Alarm Relay: Normally Open
8	Not Used
9	Alarm Relay: Normally Closed

### B) Status Requests

Table 1.1 lists the status requests for the 2017-2717-140 and briefly describes them.

Table 1.1 2017-2717-140 Status Requests		
Command	Syntax*	Description
Command Status	{aaS1}	Returns {aaS1bbbbccccdddeeffLMNOP} where:
		• bbbb = Tx frequency (bbbbbbb - 7 characters,opt X, X1)
		• cccc = Rx frequency (ccccccc - 7 characters,opt X, X1)
		• ddd = Tx gain (-10 to 30)
		• ee = Rx gain (00 to 50)
		• ff = Tx input level (10 to 40 => -10 to -40 dBm)
		• L = 0 - non-inverted Receiver; L = 1 - inverted
		• M = 0 - Receiver synth alarm
		• N = 0 - Transmitter synth alarm
		• O = 0 - Summary alarm
		• P = 0 - Transmit signal disabled (muted)
External 10MHz (option -E)	{aaS2}	Returns {aaS2b} where:
		• b = 1 - External 10MHz selected

\* **PLEASE NOTE: The Address (aa) should only be used when RS-485 is selected (option -Q ONLY)**

## C) Commands

Table 1.2 lists the commands for the 2017-2717-140 and briefly describes them. After a command is sent the 2017-2717-140 sends a return “>” indicating the command has been received and executed.

**General Command Format** - The general command format is {aaCND...}, where:

- { = start byte
- aa = address (RS-485 only **option -Q**)
- C = 1 character, either C (command) or S (status)
- N = 1-digit command or status number, 1 through 9
- D = 1 character or more of data (depends on command)
- } = stop byte

Table 1.2 2017-2717-140 Commands		
Command	Syntax*	Description
Set Transmitter Frequency	{aaC1xxxx}	where: <ul style="list-style-type: none"> <li>• xxxx = 4 characters (7 characters, option X, X1)</li> <li>• Range: 2000 to 2700 MHz, (2000000 to 27000000, option X, X1)</li> </ul>
Set Transmitter Input Level	{aaClxx}	where: <ul style="list-style-type: none"> <li>• xx = 2 characters</li> <li>• Range: 10 to 40 (-10 to -40 dBm)</li> </ul>
Set Receiver Frequency	{aaC2xxxx}	where: <ul style="list-style-type: none"> <li>• xxxx = 4 characters (7 characters, option X, X1)</li> <li>• Range: 950 to 1750 MHz (950000 to 1750000, option X, X1)</li> </ul>
Set Transmit Gain	{aaC3xxxx}	where: <ul style="list-style-type: none"> <li>• xxxx = 2 or 3 characters</li> <li>• Range: -10 to 30 (-10 dB to 30 dB, in 1 dB steps)</li> </ul>
Set Receiver Gain	{aaC4xxx}	where: <ul style="list-style-type: none"> <li>• xx = 2 characters</li> <li>• Range: 00 to 50 (00 dB to 50 dB, in 1 dB steps)</li> </ul>
Enable Tx	{aaCAx}	where x =: <ul style="list-style-type: none"> <li>• 0 to disable Tx signal</li> <li>• 1 to enable Tx signal</li> </ul>
External 10MHz (option -E)	{aaCEx}	where x =: <ul style="list-style-type: none"> <li>• 0 to disable External 10MHz ref signal</li> <li>• 1 to enable External 10MHz ref signal</li> </ul>
Downconverter Spectrum	{aaC7x}	where x =: <ul style="list-style-type: none"> <li>• 0 for non-inverted</li> <li>• 1 for inverted</li> </ul>
Enable Remote	#	Just # sign
Disable Remote	{aaCRO}*}	{CR and zero}

\* **PLEASE NOTE: The Address (aa) should only be used when RS-485 is selected (option -Q ONLY)**

## 2.0 Installation

### 2.1 Mechanical

The 2017-2717-140 consists of one RF/Controller PCB housed in a 1 RU (1 3/4 inch high) by 16 inch deep chassis. A switching,  $\pm 12$ ,  $+5$ ,  $+24$  VDC power supply provides power for the assemblies. The 2017-2717-140 can be secured to a rack using the 4 holes on the front panel. Figure 2.0 shows how the 2017-2717-140 is assembled.

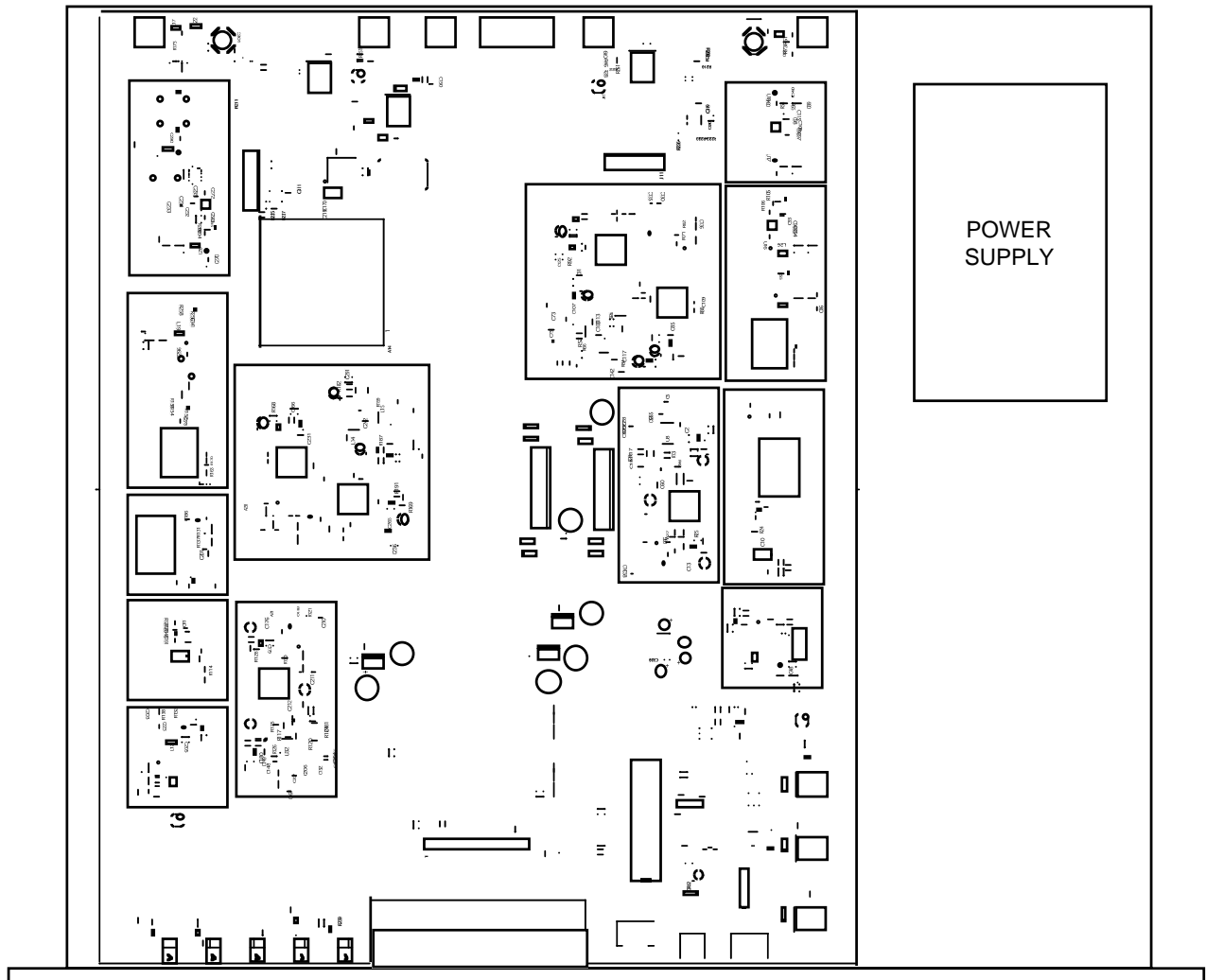

**Figure 2.0 Model 2017-2717-140 Mechanical Assembly**



## 2.2 Rear Panel Input/Output Signals and Control - Figure 2.1 shows the input and output connectors on the rear panel.

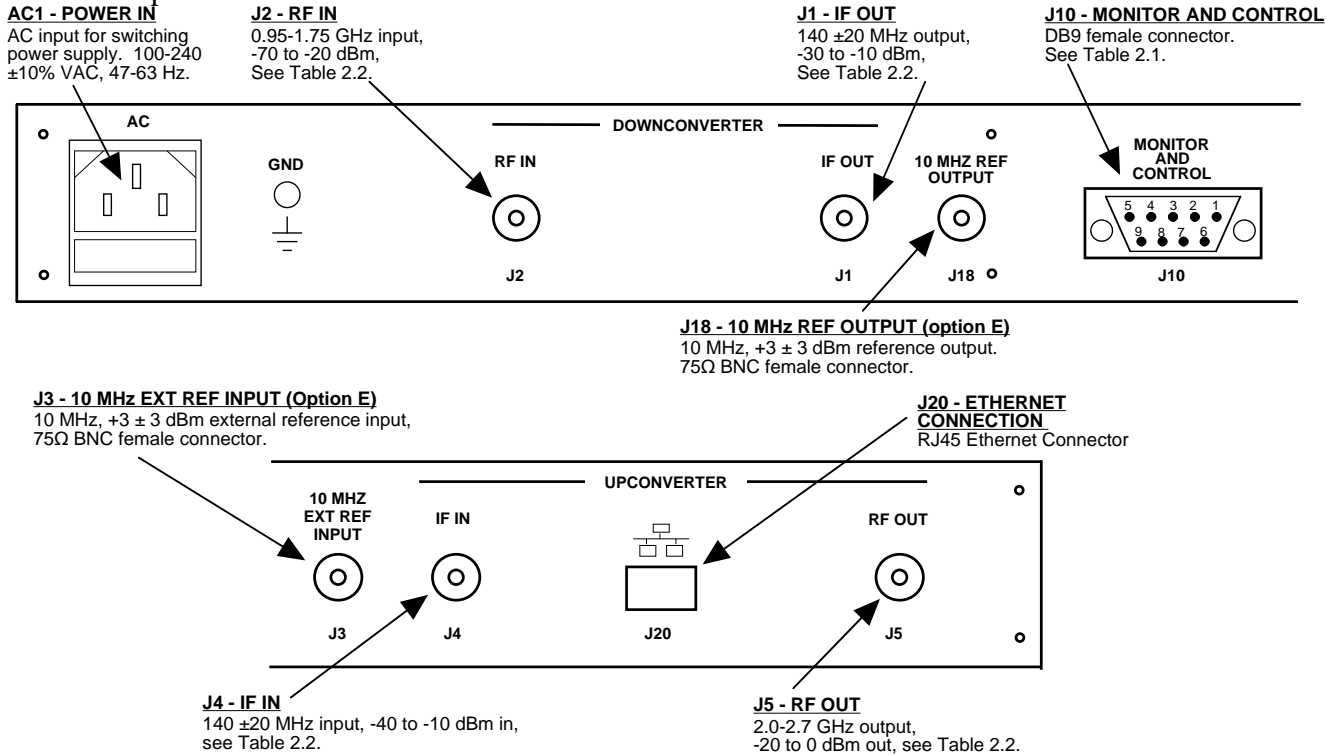

Figure 2.1 Model 2017-2717-140 Rear Panel I/O's

TABLE 2.1 J10 Pinouts (RS-232C/422/485*)	
Pin	Function
1	Rx-
2	Rx+ (RS-232C)
3	Tx+ (RS-232C)
4	Tx-
5	GND
6	Alarm Relay: Common
7	Alarm Relay: Normally Open
8	Not Used
9	Alarm Relay: Normally Closed

### \*Remote Serial Interface

Interface: DB-9 Male

Protocol: RS-232C (RS-232C/422/485 **option -Q**), 9600 baud rate, no parity, 8 data bits, 1 start bit, 1 stop bit.

TABLE 2.2 IF/RF Connector Options		
Option	IF	RF
STD	BNC, 75 $\Omega$	Type F, 75 $\Omega$
-D	BNC, 50 $\Omega$	BNC, 50 $\Omega$
-N	BNC, 75 $\Omega$	Type N, 50 $\Omega$
-M	BNC, 50 $\Omega$	Type N, 50 $\Omega$
-S	BNC, 50 $\Omega$	SMA, 50 $\Omega$
-SS	SMA, 50 $\Omega$	SMA, 50 $\Omega$

## 2.3 Front Panel Controls and Indicators - The following are the front panel controls and indicators.

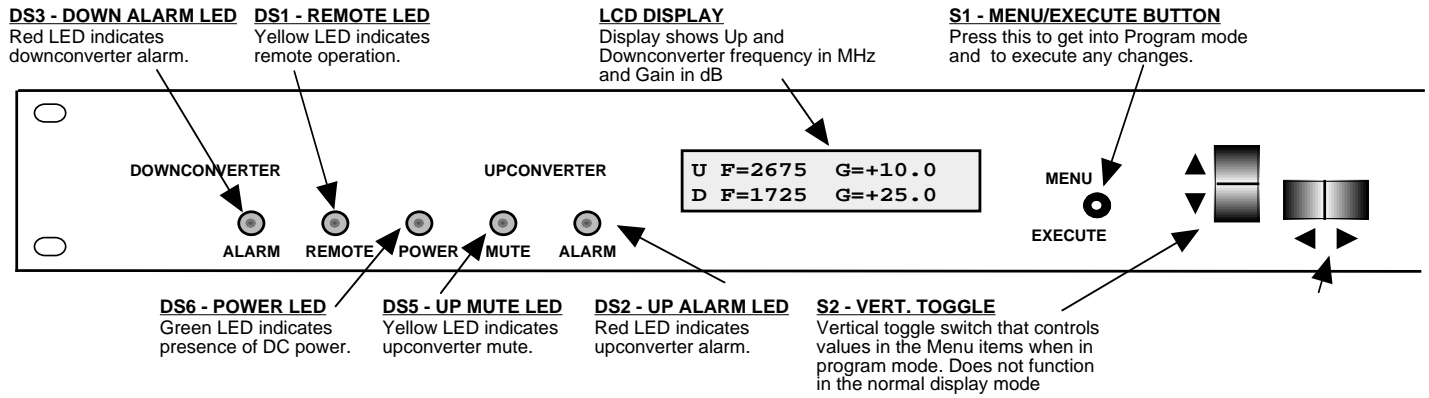

**Figure 2.2 Model 2017-2717-140 Front Panel Controls and Indicators**

## 2.4 Installation / Operation

### 2.4.1 Installing and Operating the 2017-2717-140, Upconverter Section

- 1.) Connect a -40 dBm to -10 dBm signal to IF In, J4 (Figure 2.1).
- 2.) Connect the RF OUT, J5, to the external equipment.
- 3.) Connect 100-240  $\pm$ 10 VAC, 47 - 63 Hz to AC on the back panel.
- 4.) Set the desired output frequency (See Section 2.5 Menu Settings).
- 5.) Set the gain to get an output level in the -40 to -10 dBm range (See Section 2.5 Menu Settings).
- 6.) Set the gain to get an output level in the -20 to -0 dBm range (See Section 2.5 Menu Settings).
- 7.) Be sure DS6 (green, DC Power) is on and DS2 (red, Alarm) is off (Figure 2.2).

### 2.4.2 Installing and Operating the 2017-2717-140, Downconverter Section

- 1.) Connect a -70 dBm to -20 dBm signal to RF In, J2 (Figure 2.1).
- 2.) Connect the IF OUT, J1, to the external equipment.
- 3.) Connect 100- 240  $\pm$ 10 VAC, 47 - 63 Hz to AC on the back panel.
- 4.) Set the desired input frequency (See Section 2.5 Menu Settings).
- 5.) Set the gain to get an output level in the -30 to -10 dBm range (See Section 2.5 Menu Settings).
- 6.) Be sure DS6 (green, DC Power) is on and DS2 (red, Alarm) is off (Figure 2.2).
- 7.) **AC Fuse** - The fuse is a 5 mm X 20 mm, 2 amp slow blow (Type T) and is inserted in the far slot in the drawer below the AC input as shown in Figure 2.3. There is a spare fuse in the near slot. If a fuse continues to open, the power supply is most likely defective.

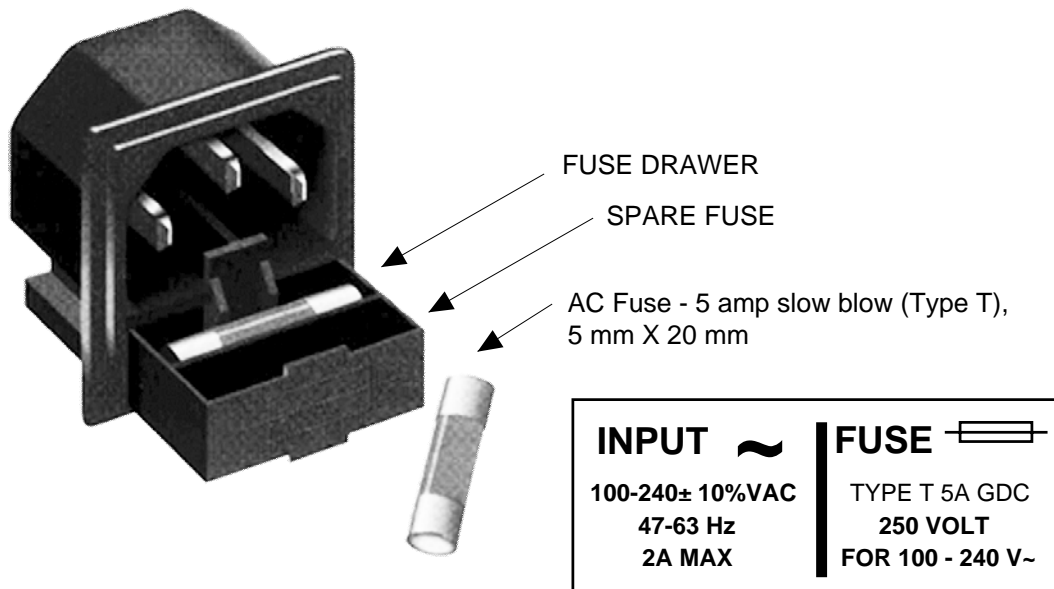

Figure 2.3 Fuse Location and Spare Fuse

## 2.5 Menu Settings

**2.5.1 Functions** - This section describes operation of the front panel controls. There are three operator switches, the LCD display and alarm indicator LEDs. All functions for the equipment are controlled by these components. The functions are (see Figure 2.4):

### Power Up

### Normal Display

- Menu 1** Up Frequency in MHz
- Menu 2** Up Input Lvl (Set from -40 to -10)
- Menu 3** Up Gain (+30 to -10)
- Menu 4** Down Frequency in MHz
- Menu 5** Down Gain (set +50 to 0 for -20 to -10 dBm out range)
- Menu 6** Up Mute
- Menu 7** Set Unit to Remote Operation
- Menu 8** Set Downconverter Spectrum Sense
- Menu 9** Select External 10 MHz Ref (option -E)
- Menu 10** Set RS-485 mode (option -Q)
- Menu 11** Set RS-485 address (option -Q)
- Menu 12** View PCB Temperature (option -T)

**Save Menu** At the end or when “R” is selected from any of the above menus

Alarm indications appear on the LEDs (see figure 2.2).

All program changes must start with the operation of the Menu/Execute switch and must also end with the operation of the Menu/Execute switch verified by the “Save Settings?” Menu. If this sequence is not followed, none of the changes will take effect. If programming is initiated and no operator action takes place for approximately 12 seconds (before the final press of the Menu/Execute switch) the display will revert to its previous status and you will need to start over.

## 2.5.2 Power-On Settings

**NOTE: THE LAST STATUS OF A UNIT IS RETAINED EVEN WHEN POWER IS REMOVED. WHEN POWER IS RESTORED, THE UNIT WILL RETURN TO IT'S PREVIOUS SETTINGS.**

When power is first applied, the LCD display goes through three steps.

1. The LCD goes black to show all segments are functioning.
2. The software version will be displayed.

REV 1.00
----------

3. The present frequency and gain of the up and downconverter is shown.

U	F=2675	G=+10.0
D	F=1725	G=+25.0

The unit is now operational and ready for any changes the operator may desire.

## 2.5.3 Control Switches

1. **Menu/Execute** - Any change to the programming of the unit must be initiated by pressing the Menu/Execute switch and completed by pressing the Menu/Execute switch.
2. **Horizontal Switch** - This switch is mounted so its movement is horizontal and moves the cursor left or right.
3. **Vertical Switch** - This switch is mounted so its movement is vertical and has two functions:
  - a. During frequency, gain, input level changes, the vertical movement will raise or lower the number in the direction of the arrows.
  - b. For other functions such Mute on/off, the vertical switch will alternately turn the function on or off regardless of the direction operated.

## 2.5.4 Frequency Changes

At any time during the modification process, if you have made a mistake and do not wish to save the changes you have made, **do not press the Menu/Execute switch**; simply do nothing for approximately 12 seconds, and the system will return to the normal operating mode or scroll to “**R**” and push the menu/Execute switch and select “**NO**” in the “**SAVE SETTINGS?**” window.

To change the FREQUENCY:

Operate the Menu/Execute switch until you get to the menu item you want to change (see Figure 2.4 for the sequence of menu options). The following display is for changing the upconverter frequency:

```
UP  F = 2225.000      R
```

Pressing the Up/Down switch down will toggle the display to:

```
UP  F = 2125.000      R
```

By using the horizontal rocker switch the cursor can be moved left or right.

```
UP  F = 2125.000      R
```

**NOTE: CHANGES DO NOT TAKE PLACE ON FREQUENCY UNTIL YOU GO TO THE SAVE MENU AND INDICATE YOU WANT TO SAVE THE CHANGES.**

When the display indicates the value desired you can push the Menu/Execute switch to the next item:

```
UP  INLVL = -20      R
```

**NOTE: CHANGES TAKE PLACE ON LEVEL AND GAIN IMMEDIATELY BUT DO NOT GET SAVED UNTIL YOU GO TO THE SAVE MENU AND INDICATE YOU WANT TO SAVE THE CHANGES.**

OR you can scroll to “**R**”, push the Menu/Execute switch to get to:

```
SAVE SETTINGS?      Y N
```

Selecting **Y** will save the new settings. Selecting **N** will revert to the previous settings.

Pushing the Menu/Execute switch then takes you to the :

```
U  F=2675      G=+10.0
D  F=1725      G=+25.0
```

Figure 2.4 shows all the menu items and how to make changes.

## 2.5.5 Gain Changes

When you get to this menu note that the gain changes will be made as you make them but if you do not wish to save the changes you have made, scroll to “**R**” and push the menu/Execute switch and select “**NO**” in the “**SAVE SETTINGS?**” window or **do not press the Menu/Execute switch**; simply do nothing for approximately 12 seconds, and the system will return to the normal operating mode.

### 2.5.5.1 Upconverter Gain

To set the upconverter gain, first push the Menu/Execute switch to get to the gain setting:

Operate the Menu/Execute switch until you get to the menu item you want to change see Figure 2.4 for the sequence of menu options.

The following display is for changing the upconverter input level. This is an important setting to optimize spurious and should be made as accurately as possible:

UP INLVL = -20	R
----------------	---

Pressing the Up/Down switch to change the level in 1 dB steps and then push the Menu/Execute switch to get to the Gain setting:

UP G = +10.0	R
--------------	---

By using the horizontal rocker switch the cursor can be moved left or right .

Pressing the Up/Down switch down will toggle the display digit selected until you have the desired gain.

**NOTE: THE GAIN WILL BE CHANGED AS YOU ADJUST THE NUMBERS. HOWEVER, THE VALUE WILL NOT BE STORED UNTIL YOU INDICATE YES IN THE SAVE SETTINGS WINDOW. DO NOT SET A GAIN THAT WOULD EXCEED A 0 dBm OUTPUT LEVEL.**

When the display indicates the value desired you can push the Menu/Execute switch to the next item OR you can scroll to “**R**”, push the Menu/Execute switch to get to:

SAVE SETTINGS?	<u>Y</u> N
----------------	------------

Selecting **Y** will save the new settings. Selecting **N** will revert to the previous settings.

Pushing the Menu/Execute switch then takes you to the :

U	F=2675	G=+10.0
D	F=1725	G=+25.0

Figure 2.4 shows all the menu items and how to make changes.

### 2.5.5.2 Downconverter Gain

To set the downconverter gain, first push the Menu/Execute switch to get to the gain setting:

Operate the Menu/Execute switch until you get to the menu item you want to change see Figure 2.4 for the sequence of menu options.

The following display is for changing the downconverter gain. This is an important setting to optimize spurious and should be made as accurately as possible to provide an output in the -20 to 0 dBm level range:

DN	G = + <u>1</u> 5.0	R
----	--------------------	---

Pressing the Up/Down switch to change the level in 1 or 10 dB steps. By using the horizontal rocker switch the cursor can be moved left or right. Pressing the Up/Down switch down will toggle the display digit selected until you have the desired gain.

**NOTE: THE GAIN WILL BE CHANGED AS YOU ADJUST THE NUMBERS. HOWEVER, THE VALUE WILL NOT BE STORED UNTIL YOU INDICATE YES IN THE SAVE SETTINGS WINDOW.**

When the display indicates the value desired you can push the Menu/Execute switch to the next item OR you can scroll to “R”, push the Menu/Execute switch to get to:

SAVE SETTINGS?	<u>Y</u> N
----------------	------------

Selecting **Y** will save the new settings. Selecting **N** will revert to the previous settings.

Pushing the Menu/Execute switch then takes you to the :

U	F=2675	G=+10.0
D	F=1725	G=+25.0

Figure 2.4 shows all the menu items and how to make changes.

### 2.5.5 Alarm Indications

An alarm condition will occur if any local oscillator phase lock loop (PLL) comes out of lock.



	<b>ON POWER UP</b>			
<b>Power Up</b>	REV 1.00			
	<b>NORMAL DISPLAY</b>			
<b>Normal Display</b>	U F=2675 G=+10.0 D F=1725 G=+25.0			PUSH BUTTON
	<b>PUSHING MENU/EXECUTE SEQUENCE</b>			
<b>Menu 1</b> Up Frequency	UP F=2 <u>6</u> 75 R	SCROLL <> SCROLL ↻		PUSH BUTTON
<b>Menu 2</b> Up Input Level (Set from -40 to -10)	UP INLVL=-2 <u>0</u> R	SCROLL <> SCROLL ↻		PUSH BUTTON
<b>Menu 3</b> Up Gain (+30 to -10)	UP G=+1 <u>0</u> .0 R	SCROLL <> SCROLL ↻		PUSH BUTTON
<b>Menu 4</b> Down Frequency	DN F=1 <u>3</u> 50 R	SCROLL <> SCROLL ↻		PUSH BUTTON
<b>Menu 5</b> Down Gain (set +50 to 0 for -20 to -10 dBm out level)	DN G=+2 <u>5</u> .0 R	SCROLL <> SCROLL ↻		PUSH BUTTON
<b>Menu 6</b> Up Mute	UP MUTE <u>O</u> FF R	SCROLL <> SCROLL ↻		PUSH BUTTON
<b>Menu 7</b> Set Unit to Remote Operation	REMOTE <u>O</u> FF R	SCROLL <> SCROLL ↻		PUSH BUTTON
<b>Menu 8</b> Set Downconverter Spectrum Sense	DNSPECTRUM <u>N</u> ON R	SCROLL <> SCROLL ↻		PUSH BUTTON
<b>Menu 9</b> Select 10 MHz Reference INT, EXT, or AUTO (option E)	EXT REF <u>O</u> FF R	SCROLL <> SCROLL ↻		PUSH BUTTON
<b>Menu 10</b> Set Remote Mode (option Q)	RS 485 <u>O</u> FF R	SCROLL <> SCROLL ↻		PUSH BUTTON
<b>Menu 11</b> Set RS-485 Address (option Q)	ADDRESS=0 <u>0</u> R	SCROLL <> SCROLL ↻		PUSH BUTTON
<b>Menu 12</b> View PCB Temperature (option T)	TEMP=35 DEG R	SCROLL <> SCROLL ↻		PUSH BUTTON
<b>Save?</b> When "R" is selected in any above menu or after last menu item	SAVE SETTINGS? <u>Y</u> N	SCROLL <> SCROLL ↻		PUSH BUTTON

**Figure 2.4 Menu Display and Sequence**



6170 Shiloh Road  
Alpharetta, Georgia 30005

(770) 886-8005

FAX (770) 886-7964

Toll Free 888-900-5588

WEB [www.crosstechnologies.com](http://www.crosstechnologies.com)

E-MAIL [info@crosstechnologies.com](mailto:info@crosstechnologies.com)

Printed in USA