

Instruction Manual

Model 2016-7984-720-400 Downconverter

April 2016, Rev. A

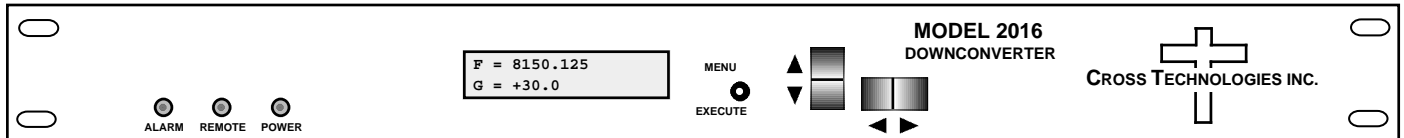

Data, drawings, and other material contained herein are proprietary to Cross Technologies, Inc., but may be reproduced or duplicated without the prior permission of Cross Technologies, Inc. for purposes of operating the equipment.

When ordering parts from Cross Technologies, Inc., be sure to include the equipment model number, equipment serial number, and a description of the part.



6170 Shiloh Road
Alpharetta, Georgia 30005

(770) 886-8005
FAX (770) 886-7964
Toll Free 888-900-5588

WEB www.crosstechnologies.com
E-MAIL info@crosstechnologies.com

INSTRUCTION MANUAL

MODEL 2016-7984-720-400 Downconverter

<u>TABLE OF CONTENTS</u>	<u>PAGE</u>
Warranty	2
1.0 General	3
1.1 Equipment Description	3
1.2 Technical Characteristics	4
1.3 Monitor & Control Interface	6
1.4 Environmental Use Information	10
2.0 Installation	11
2.1 Mechanical	11
2.2 Rear Panel Inputs & Outputs	12
2.3 Front Panel Controls & Indicators	12
2.4 Operation	13
2.5 Menu Settings	14

WARRANTY - The following warranty applies to all Cross Technologies, Inc. products.

All Cross Technologies, Inc. products are warranted against defective materials and workmanship for a period of one year after shipment to customer. Cross Technologies, Inc.'s obligation under this warranty is limited to repairing or, at Cross Technologies, Inc.'s option, replacing parts, subassemblies, or entire assemblies. Cross Technologies, Inc. shall not be liable for any special, indirect, or consequential damages. This warranty does not cover parts or equipment which have been subject to misuse, negligence, or accident by the customer during use. All shipping costs for warranty repairs will be prepaid by the customer. There are not other warranties, express or implied, except as stated herein.



6170 Shiloh Road
Alpharetta, Georgia 30005

(770) 886-8005
FAX (770) 886-7964
Toll Free 888-900-5588

WEB www.crosstechnologies.com
E-MAIL info@crosstechnologies.com

MODEL 2016-7984-720-400 Downconverter

1.0 General

1.1 Equipment Description

The 2016-7984-720-400 Downconverter converts 7.9 to 8.4 GHz to 720 \pm 200 MHz in 125 kHz steps, $F_c = 8.1$ -8.25 GHz (1 kHz steps, option X1006) with low group delay and flat frequency response. Synthesized local oscillators (LO) provide low phase noise and ± 0.01 ppm stability frequency selection. Multi-function push button switches select the RF frequency, gain, and other parameters. Front panel LEDs provide indication of DC power (green), PLL alarm (red), and remote operation (yellow). Gain is adjustable manually over a +30 to +50 dB range as adjusted by the front panel multi-function push-button switches. Remote operation allows selection of frequency and gain. Parameter selection and frequency and gain settings appear on the LCD display. Connectors are BNC (female) for RF output and the 10MHz reference input and output, and Type N (female) for the RF input. External 10 MHz is standard. A 10 MHz output connector contains either the internal or external 10 MHz reference signal. It is powered by a 100-240 \pm 10% VAC power supply, and in a 1.75" X 19" X 16" rack mount chassis.

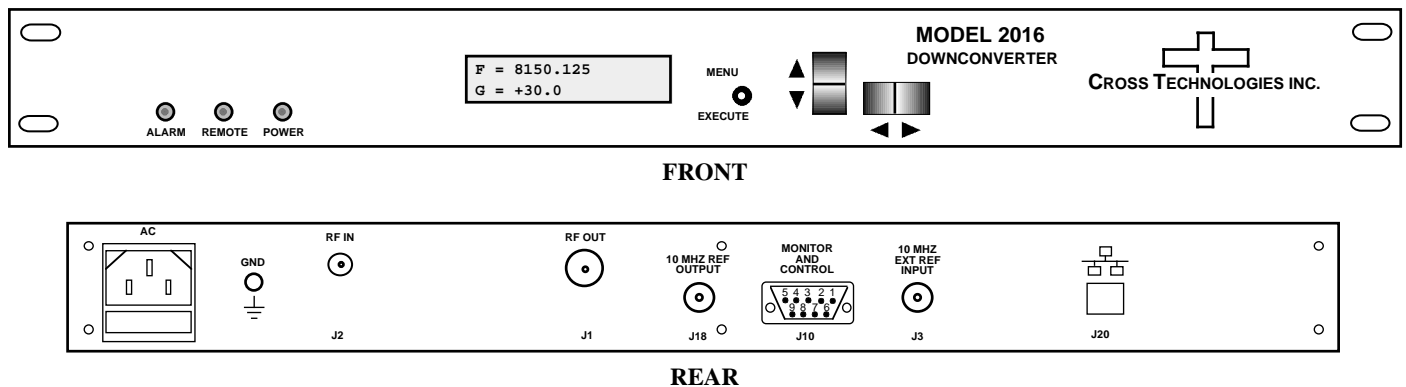

FIGURE 1.1 Model 2016-7984-720-400 Front and Rear Panels

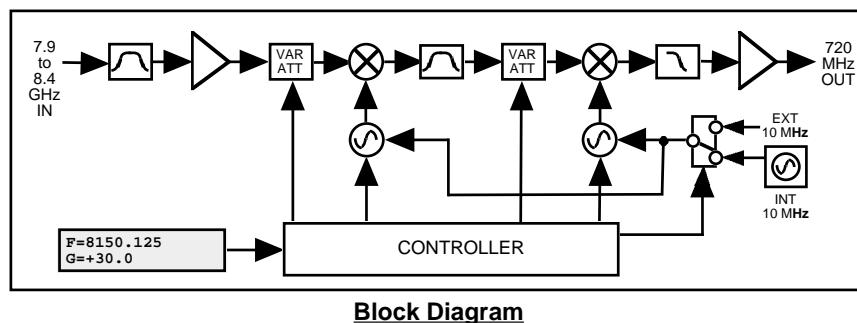

FIGURE 1.2 Model 2016-7984-720-400 Downconverter Block Diagram

1.2 Technical Characteristics

TABLE 1.0 2016-7984-720-400 Downconverter Specifications*

Input Characteristics (RF)					
Impedance / Return Loss	50Ω / 14 dB (See TABLE 2.2 for connector options)				
Frequency	7.9 to 8.4 GHz, (Fc= 8.1 - 8.25 GHz)				
Nosie Figure, maximum	15 dB (maximum gain)				
Level Range	-70 to -40 dBm				
Output Characteristics (IF)					
Impedance / Return Loss	75Ω / 14 dB minimm (See TABLE 2.2 for connector options)				
Frequency	720 ± 200 MHz				
Level Range	-20 to 0 dBm				
1dB Compression	+10 dBm				
Channel Characteristics					
Gain Range (adjustable)	+ 30 to +50 dB, 0.5 ±0.5 dB steps				
Image Rejection	> 50 dB, minimum				
Spurious Response	<- 55 dBC, typical; < -50 dBC, maximum, in band				
Frequency Response	±1.5 dB, 400 MHz BW, Fc = 8.1 - 8.25 GHz				
Group Delay, Maximum	10 ns total (parabolic + linear + ripple), 400 MHz band, Fc = 8.1 - 8.25 GHz				
Frequency Sense	Non-inverting				
Synthesizer Characteristics					
Frequency Accuracy	±0.01 ppm internal reference; external reference input				
Frequency Step	125 kHz minimum, Fc = 8.1 - 8.25 GHz; (1 kHz steps, option X1006)				
10 MHz Level (In / Out)	Input = +1 to +8 dBm in; Output = 3 ± 3 dBm				
Phase Noise @ Frequency >	100 MHz	1 kHz	10 kHz	100 kHz	1 MHz
dBC/Hz	-70	-70	-80	-95	-105
Controls, Indicators					
Frequency/Gain Selection	Direct readout LCD, pushbutton switches or remote selection				
Power/Alarm/Remote	Green LED; Red LED; Yellow LED				
Remote	RS232C, 9600 baud; RS485/422 or Ethernet Optional				
Other					
RF Connectors	RF Type N (female), 50Ω/RF - BNC (female), 75Ω				
10 MHz Connectors	BNC (female), 75Ω, works with 50 or 75 ohms				
Alarm/Remote Connector	DB9 - NO or NC Contact Closure on Alarm				
Size	19 inch, 1 RU Standard Chassis 1.75" high X 16.0" deep				
Power	100-24 ±10% VAC, 47-63 Hz, 45 watts maximum				

Technical Characteristics continued on page 5...

Technical Characteristics continued from page 4...

Available Options	
- W66	-50 to -20 dBm input
- W31	Extended Temperature 0C to +50C
- W1006	1 kHz frequency step
Remote M&C Interfaces	
- Q	RS-485/422
- W8	Ethernet with Web Browser
- W18	Ethernet with Web Browser & SNMP
- W28	Ethernet with TCP/IP, Telnet®
- W828	Ethernet with W18 + W28
Connectors/Impedance	
- STD	-50Ω Type N (RF), 75Ω BNC (IF)
- M	50Ω Type N (RF), 50Ω BNC (IF)
- S	50Ω SMA (RF), 50Ω BNC (IF)
- S7	50Ω SMA (RF), 75Ω BNC (IF)
Contact Cross for other options.	
*10°C to 40°C; Specifications subject to change without notice	
© 2016 Cross Technologies, Inc.	

1.3 Monitor and Control Interface

A) Remote serial interface

Protocol: RS-232C, 9600 baud rate, no parity, 8 data bits, 1 start bit, and 1 stop bit.
(RS-232C, RS-422, or **RS-485 - option -Q**)

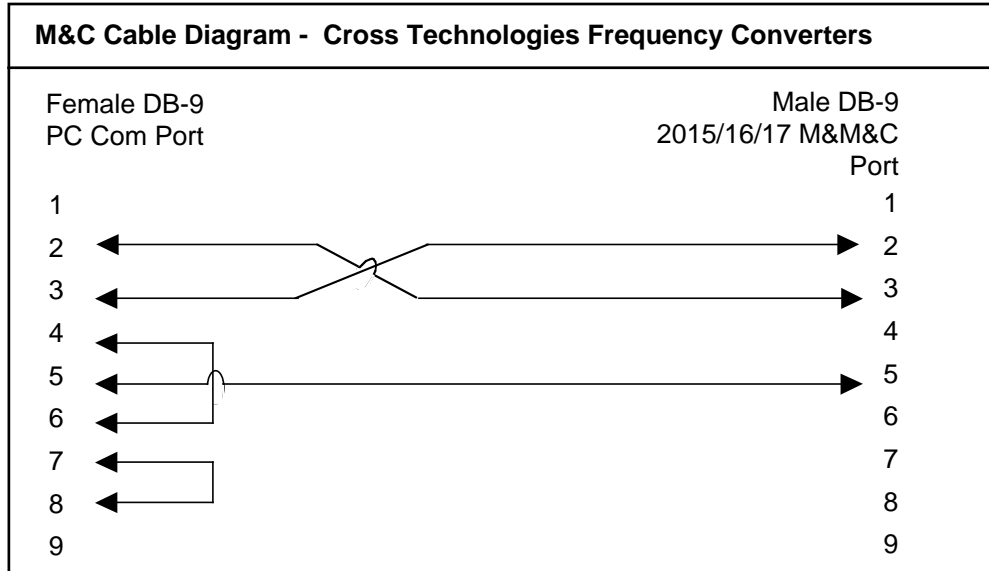

Connector: Rear panel, DB-9 female

J10 Pinouts (RS-232C/422/485)	
Pin	Function
1	Rx-
2	Rx+ (RS-232C)
3	Tx+ (RS-232C)
4	Tx-
5	GND
6	Alarm Relay: Common
7	Alarm Relay: Normally Open
8	Not Used
9	Alarm Relay: Normally Closed

B) Status Requests

Table 1.1 lists the status requests for the 2016-7984-720-400 and briefly describes them.

* PLEASE NOTE: The two character {aa}(00-31) prefix, in the table below, should be used ONLY when RS-485, (OPTION-Q), is selected.

TABLE 1.1 2016-7984-720-400 Status Requests/Inquires		
Command	Syntax*	Description
Frequency Inquiry	{aaSF}	Returns: {aaSFxxxxxx} Where: <ul style="list-style-type: none"> • aa = unit address, range = 00 to 31, only used if interface is RS485, otherwise omit • F = command code • xxxxxx = frequency in kHz The unit will append the '>' character if the command is successfully processed.
Gain Inquiry	{aaSG}	Returns: {aaSGxx} Where: <ul style="list-style-type: none"> • aa = unit address, range = 00 to 31, only used if interface is RS485, otherwise omit. • G = command code • xx = unit's gain setting in dB The unit will append the '>' character if the command is successfully processed.
Reference Mode Inquiry	{aaSE}	Returns: {aaSEx} Where: <ul style="list-style-type: none"> • aa = unit address, range = 00 to 31, only used if interface is RS485, otherwise omit. • E = command code • x = 0 if reference mode is internal, x = 1 if external The unit will append the '>' character if the command is successfully processed.
Alarm Inquiry	{aaSA}	Returns: {aaSAx} Where: <ul style="list-style-type: none"> • aa = unit address, range = 00 to 31, only used if interface is RS485, otherwise omit • A = command code • x = 0 if alarm is off, x = 1 if alarm is on. The unit will append the '>' character if the command is successfully processed.

C) Commands - Table 1.1 lists the commands for the 2016-7984-720-400 and briefly describes them. After a command is sent, the 2016-7984-720-400 sends a return “>” indicating the command has been received and executed.

General Command Format - The general command format is {aaCND...}, where:

- { = start byte
- aa = address (**RS-485 only - option -Q**)
- C = 1 character, either C (command) or S (status)
- N = 1 character command or status request
- D = 1 character or more of data (depends on command)
- } = stop byte

* PLEASE NOTE: The two character {aa}(00-31) prefix, in the table below, should be used ONLY when RS-485, (OPTION-Q), is selected.

Table 1.2 2016-7984-720-400 Commands		
Command	Syntax*	Description
Set Frequency	{aaCFxxxxxx}	Where: <ul style="list-style-type: none"> • aa = unit address, range = 00 to 31, only used if interface is RS485, otherwise omit • F = command code • xxxxxx=frequency in kHz, range = 8100000 to 8200000 (8100.000 to 8200.000 MHz, 0.125 MHz steps) example: {CF8175125} Will set the unit's frequency to 8175.125 MHz The unit will reply with the '>' character if the command is successfully processed.
Set Gain	{aaCGxx}	Where: <ul style="list-style-type: none"> • aa = unit address, range = 00 to 31, only used if interface is RS485, otherwise omit. • G = command code • xx = gain in dB, range = 30 to 50 in 0.5 dB steps. example: {CG345} Will set the unit's gain to 34.5 dB The unit will reply with the '>' character if the command is successfully processed.
Set Reference Mode	{aaCEx}	Where: <ul style="list-style-type: none"> • aa = unit address, range = 00 to 31, only used if interface is RS485, otherwise omit • E = command code • x = 0 to set to internal reference, • x = 1 to set to external reference example: {CE1} Will set the reference mode to External. The unit will reply with the '>' character if the command is successfully processed.

(Continued on page 9)...

(Continued from page 8)...

Table 1.2 2016-7984-720-400 Commands, (continued)...		
Command	Syntax*	Description
Set Remote Off	{aaCRO}	Where:
		• aa = unit address, range = 00 to 31, only used if interface is RS485, otherwise omit.
		• R = command code
		• 0, ascii number zero.
		example: {CRO}
		Will disable the unit's serial M&C port.
		The unit will reply with the '>' character if the command is successfully processed.
		(Note: this command only affects the serial M&C port, the ethernet port is always on and will not be affected).
Set Remote On	#	Just the ascii pound sign, (0x23)
		Will enable the unit's serial M&C port.
		The unit will reply with the '>' character if the command is successfully processed.
		(Note: this command only affects the serial M&C port, the ethernet port is always on and will not be affected).

1.4 Environmental Use Information

- A. Rack-Mounting** - To mount this equipment in a rack, please refer to the installation instructions located in the user manual furnished by the manufacturer of your equipment rack.
- B. Mechanical loading** - Mounting of equipment in a rack should be such that a hazardous condition does not exist due to uneven weight distribution.
- C. Elevated operating ambient temperature** - If installed in a closed or multiunit rack assembly, the operating ambient temperature of the rack may be greater than room ambient temperature. Therefore, consideration should be given to Tmra (Maximum Recommended Ambient Temperature).
- D. Reduced air flow** - Installation of the equipment in a rack should be such that the amount of air flow required for safe operation of the equipment is not compromised. Additional space between units may be required.
- E. Circuit Overloading** - Consideration should be given to the connection of the equipment to the supply circuit and the effect that overloading of circuits could have on over current protection and supply wiring. Appropriate consideration of equipment name plate rating should be used, when addressing this concern.
- F. Reliable Earthing** - Reliable earthing of rack-mounted equipment should be maintained. Particular attention should be given to supply connections other than direct connection to the Branch (use of power strips).
- G. Top Cover** - There are no serviceable parts inside the product so, the Top Cover should not be removed. If the Top Cover is removed the ground strap and associated screw **MUST BE REINSTALLED** prior to Top Cover screw replacement. **FAILURE TO DO** this may cause **INGRESS** and/or **EGRESS** emission problems.

2.0 Installation

2.1 Mechanical

The 2016-7984-720-400 consists of one RF/Controller PCB housed in a 1 RU (1 3/4 inch high) by 16 inch deep chassis. A switching, ± 12 , +24, +5 VDC power supply provides power for the assemblies. The 2016-152 can be secured to a rack using the 4 holes on the front panel. Figure 2.1 shows how the 2016-7984-720-400 is assembled.

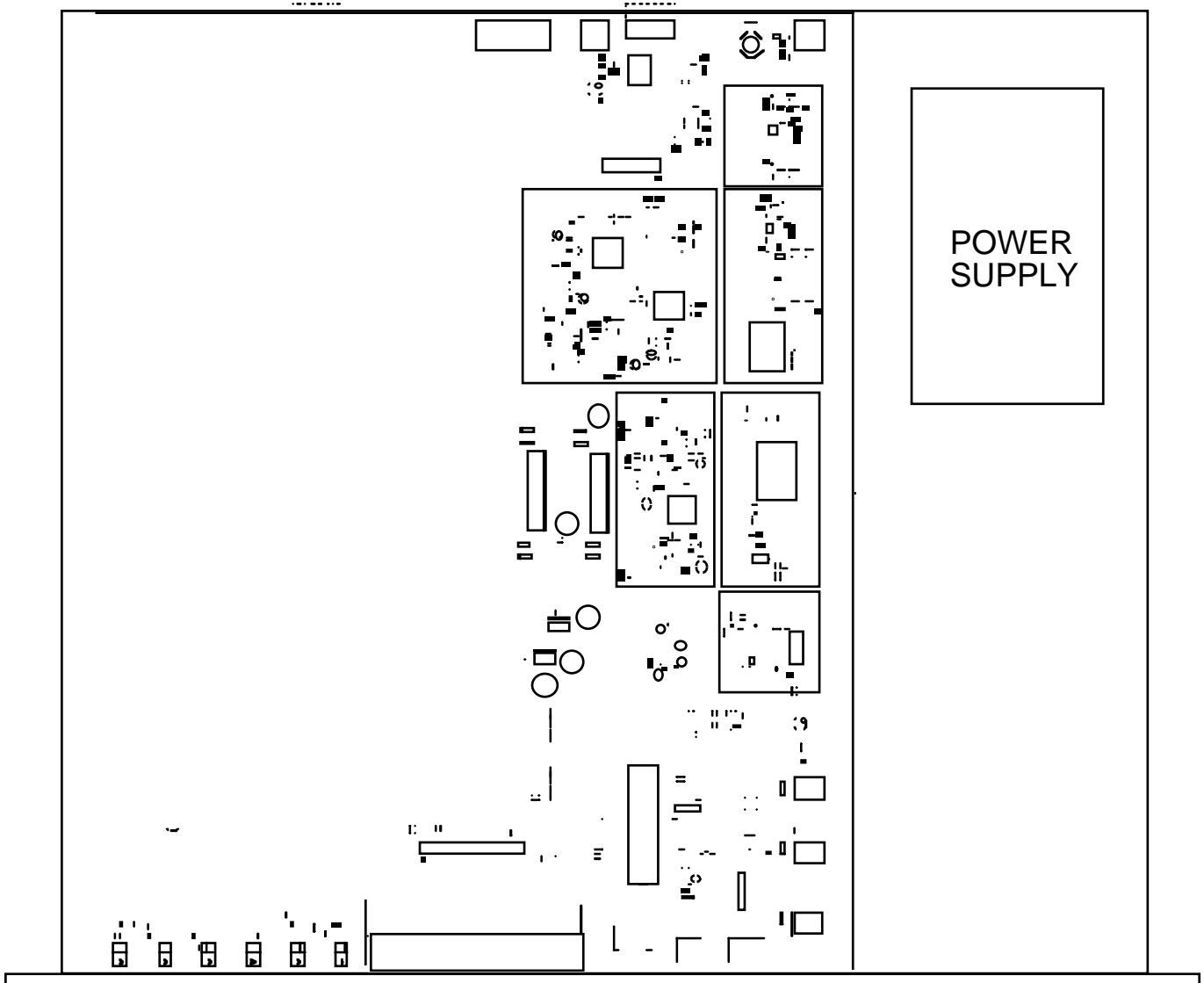

FIGURE 2.1 2016-7984-720-400 Mechanical Assembly

2.2 Rear Panel Input/Output Signals

Figure 2.2 shows the input and output connectors on the rear panel.

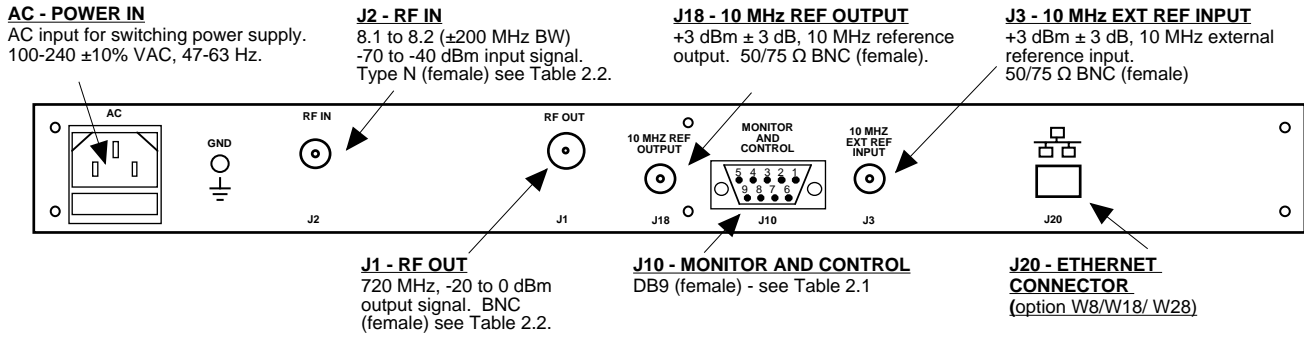

FIGURE 2.2 2016-7984-720-400 Rear Panel I/Os

TABLE 2.1 J10 Pinouts (RS-232C*)	
Pin	Function
1	Not Used
2	Rx+ (RS-232C)
3	Tx+ (RS-232C)
4	Not Used
5	GND
6	Alarm Relay: Common
7	Alarm Relay: Normally Closed
8	Not Used
9	Alarm Relay: Normally Open

TABLE 2.2 RF Connector Options		
Option	RF	RF
M	BNC, 50 Ω	Type N, 50 Ω
N	BNC, 75 Ω	Type N, 50 Ω
S	BNC, 50 Ω	SMA, 50 Ω
SS	SMA, 50 Ω	SMA, 50 Ω

*Remote Serial Interface

Interface: DB-9 Female

Protocol: RS-232C, 9600 baud rate, no parity,
8 data bits, 1 start bit, 1 stop bit

2.3 Front Panel Controls and Indicators

Figure 2.3 shows the front panel controls and indicators.

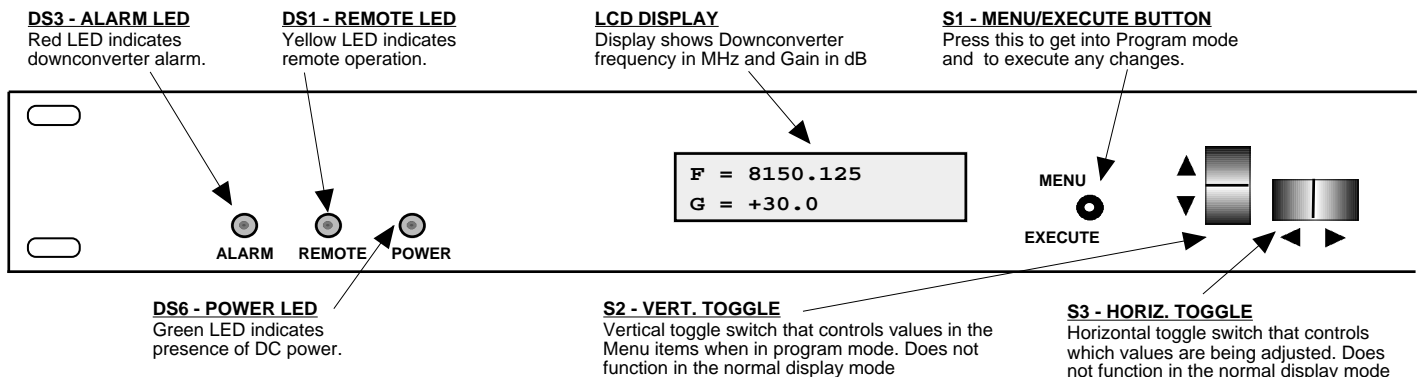

FIGURE 2.3 2016-7984-720-400 Front Panel Controls and Indicators

2.4 Operation

2.4.1 Installing and Operating the 2016-152 Downconverter

1. Connect a -70 dBm to -40 dBm signal to RF IN, J2 (Figure 2.2)
2. Connect the IF OUT, J1, to the external equipment
3. Connect 100- 240 \pm 10% VAC, 47 - 63 Hz to AC on the back panel.
4. Set the input frequency (See Section 2.5 Menu Settings).
5. Set the gain for +30 to +50 dB (See Section 2.5 Menu Settings).
6. Be sure DS6 (green, DC Power) is on and DS3 (red, Alarm) is off (Figure 2.3).
7. **AC Fuse** - The fuse is a 5 mm X 20 mm, 2 amp slow blow (Type T) and is inserted in the far slot in the drawer below the AC input as shown in Figure 2.4. There is a spare fuse in the near slot. If a fuse continues to open, the power supply is most likely defective.

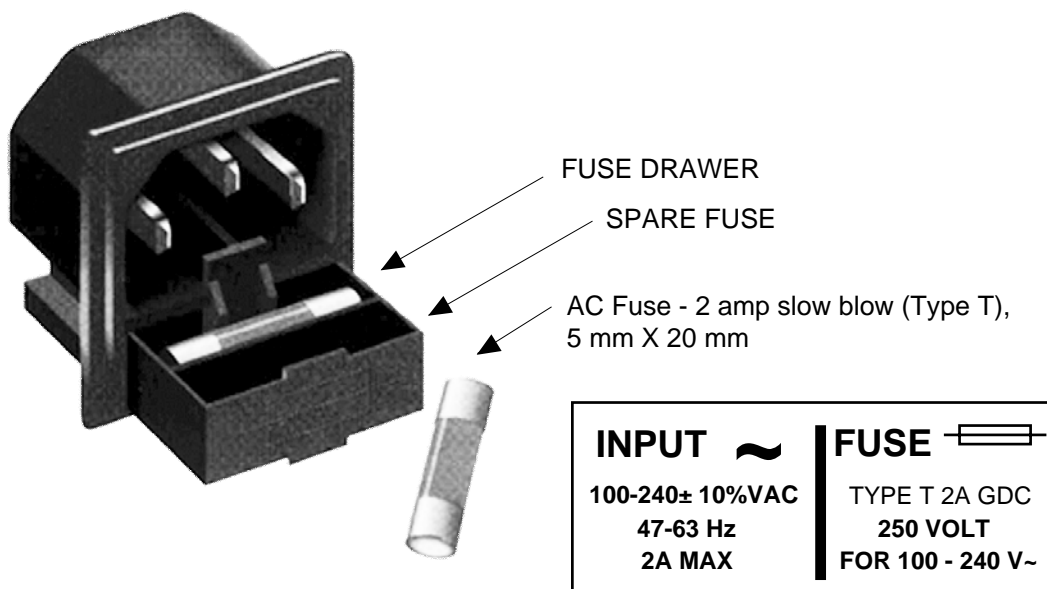

FIGURE 2.4 Fuse Location and Spare Fuse

2.5 Menu Settings

2.5.1 Functions

This section describes operation of the front panel controls. There are three operator switches, the LCD display and alarm indicator LEDs. All functions for the equipment are controlled by these components. The functions are (see Figure 2.5):

Power Up

Normal Display

- Menu 1** Frequency in MHz
- Menu 2** Gain (+30 to +50)
- Menu 3** Set Unit to Remote Operation
- Menu 4** Select External 10 MHz Ref
- Menu 5** Set Remote Mode
- Menu 6** Set RS-485 Address

Save Menu When “R” is selected in any above menu or at the end of the menu options.

Alarm indications appear on the LEDs (see figure 2.3).

All program changes must start with the operation of the Menu/Execute switch and must also end with the operation of the Menu/Execute switch verified by the “Save Settings?” Menu. If this sequence is not followed, none of the changes will take effect. If programming is initiated and no operator action takes place for approximately 30 seconds (before the final press of the Menu/Execute switch) the display will revert to its previous status and you will need to start over.

2.5.2 Power On Settings

NOTE: THE LAST STATUS OF A UNIT IS RETAINED EVEN WHEN POWER IS REMOVED. WHEN POWER IS RESTORED, THE UNIT WILL RETURN TO ITS PREVIOUS SETTINGS.

When power is first applied, the LCD display goes through three steps.

1. The LCD goes black to show all segments are functioning.
2. The software version will be displayed.

A rectangular LCD display showing the text "REV 1.00" in a monospaced font.

3. The present frequency and gain of the downconverter is shown.

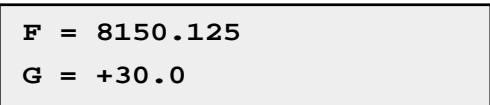
A rectangular LCD display showing two lines of text: "F = 8150.125" on the top line and "G = +30.0" on the bottom line, both in a monospaced font.

The unit is now operational and ready for any changes the operator may desire.

2.5.3 Control Switches

1. Menu/Execute - Any change to the programming of the unit must be initiated by pressing the Menu/Execute switch and completed by pressing the Menu/Execute switch.
2. Horizontal Switch - This switch is mounted so its movement is horizontal and moves the cursor left or right.
3. Vertical Switch - This switch is mounted so its movement is vertical and has two functions:
 - a. During frequency, gain changes, the vertical movement will raise or lower the number in the direction of the arrows.
 - b. For other functions such Mute on/off, the vertical switch will alternately turn the function on or off regardless of the direction operated.

2.5.4 Frequency Changes

At any time during the modification process, if you have made a mistake and do not wish to save the changes you have made, **do not press the Menu/Execute switch**; simply do nothing for approximately 30 seconds, and the system will return to the normal operating mode or scroll to “**R**” and push the menu/Execute switch and select “**NO**” in the “**SAVE SETTINGS?**” window.

To change the FREQUENCY:

Operate the Menu/Execute switch until you get to the menu item you want to change see Figure 2.5 for the sequence of menu options. The following display is for changing the downconverter frequency:

```
F = 8100.000      R
```

Pressing the Up/Down switch down will toggle the display to:

```
F = 8200.000      R
```

By using the horizontal rocker switch the cursor can be moved left or right .

```
F = 8200.000      R
```

NOTE: CHANGES DO NOT TAKE PLACE ON FREQUENCY UNTIL YOU GO TO THE SAVE MENU AND INDICATE YOU WANT TO SAVE THE CHANGES.

When the display indicates the value desired you can push the Menu/Execute switch to get to the next item:

```
G = +30.0      R
```

OR you can scroll to “**R**”, push the Menu/Execute switch to get to:

```
SAVE SETTINGS?      Y N
```

Selecting **Y** will save the new settings. Selecting **N** will revert to the previous settings.

Pushing the Menu/Execute switch then takes you to this:

```
F = 8150.125  
G = +30.0
```

Figure 2.5 gives the menu items and how to make changes.

2.5.5 Gain Changes

When you get to this menu note that the gain changes will be made as you make them but if you do not wish to save the changes you have made, scroll to “**R**” and push the Menu/Execute switch and select “**NO**” in the “**SAVE SETTINGS?**” window or **do not press the Menu/Execute switch**; simply do nothing for approximately 30 seconds, and the system will return to the normal operating mode.

To change the GAIN:

Push the Menu/Execute switch to get to the gain setting (See Figure 2.5 for the sequence of menu options):

G = +<u>3</u>0.0	R
-------------------------	----------

Pressing the Up/Down switch will change the gain in 1 or 10 dB steps depending on the cursor location:

G = +<u>4</u>0.0	R
-------------------------	----------

By using the horizontal rocker switch the cursor can be moved left or right.

Pressing the Up/Down switch will toggle the display digit selected until you have the desired gain.

G = +40.<u>0</u>	R
-------------------------	----------

NOTE: THE GAIN WILL BE CHANGED AS YOU ADJUST THE NUMBERS. HOWEVER, THE VALUE WILL NOT BE STORED UNTIL YOU INDICATE YES IN THE SAVE SETTINGS WINDOW.

When the display indicates the value desired you can push the Menu/Execute switch to get to the next item:

REMOTE	<u>O</u>FF	R
---------------	-------------------	----------

OR you can scroll to “**R**” and push the Menu/Execute switch to get to:

SAVE SETTINGS?	<u>Y</u> N
-----------------------	-------------------

Selecting **Y** will save the new settings. Selecting **N** will revert to the previous settings.

Pushing the Menu/Execute switch then takes you to this:

F = 8150.125
G = +30.0

Figure 2.5 gives the menu items and how to make changes.

2.5.5 Alarm Indications

An alarm condition will occur if any local oscillator phase lock loop (PLL) comes out of lock. The Mute LED will light if you select Mute and the Remote LED will light when you select the Remote mode.

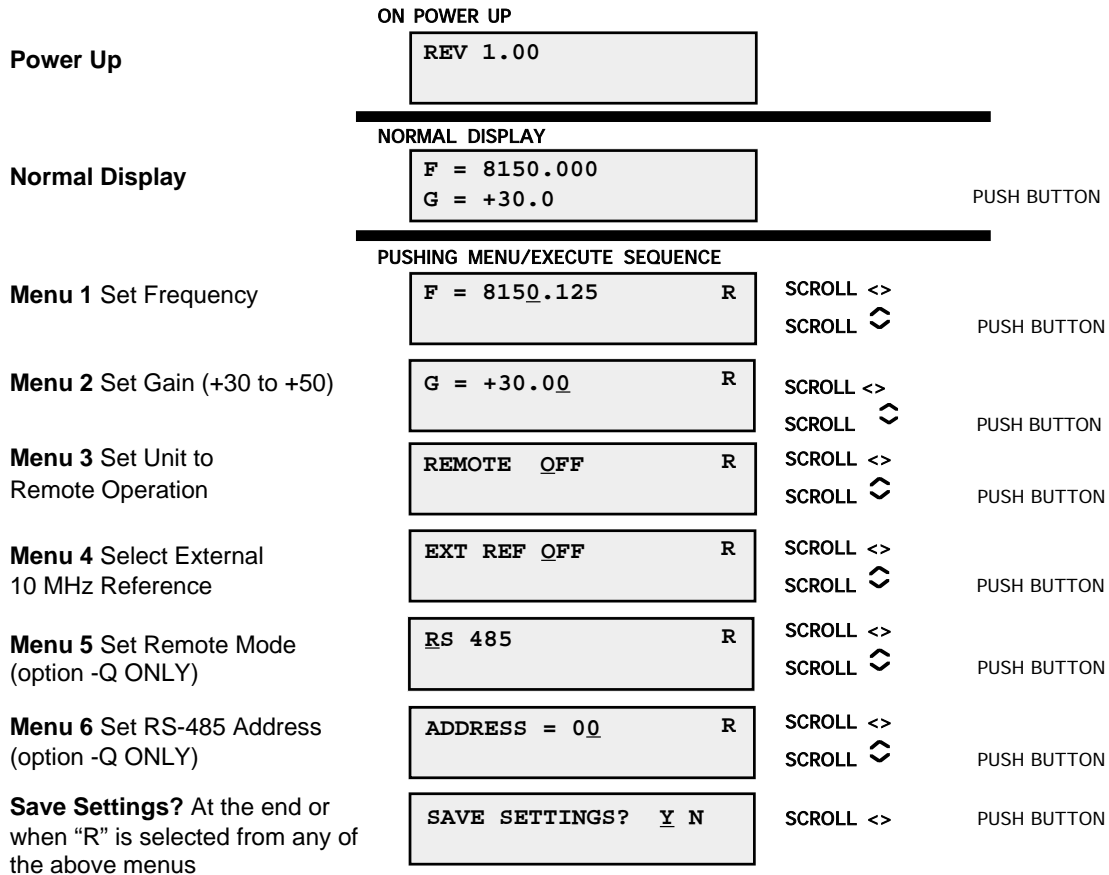

FIGURE 2.5 Menu Display and Sequence



6170 Shiloh Road
Alpharetta, Georgia 30005

(770) 886-8005
FAX (770) 886-7964
Toll Free 888-900-5588

WEB www.crosstechnologies.com
E-MAIL info@crosstechnologies.com