

Instruction Manual

Model 2004/2004R Agile Upconverter

December 2008 Rev C

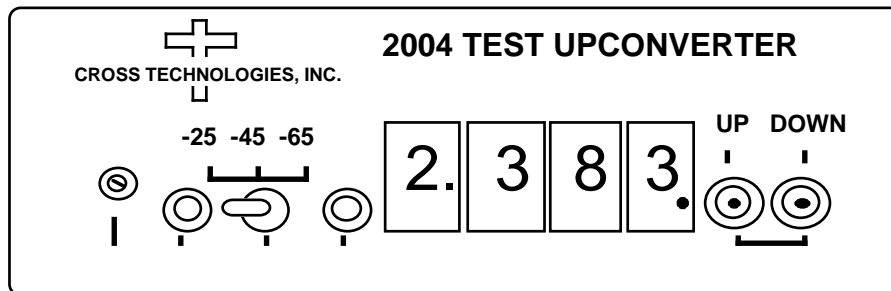

Data, drawings, and other material contained herein are proprietary to Cross Technologies, Inc., but may be reproduced or duplicated without the prior permission of Cross Technologies, Inc. for purposes of operating the equipment.

When ordering parts from Cross Technologies, Inc., be sure to include the equipment model number, equipment serial number, and a description of the part.



6170 Shiloh Road
Alpharetta, Georgia 30005

(770) 886-8005
FAX (770) 886-7964
Toll Free 888-900-5588

WEB www.crosstechnologies.com
E-MAIL info@crosstechnologies.com

INSTRUCTION MANUAL

MODEL 2004, 2004R Agile 9.5-2.05 GHz Upconverter

<u>TABLE OF CONTENTS</u>	<u>PAGE</u>
Warranty	2
1.0 General	3
1.1 Equipment Description	3
1.2 Technical Characteristics	3
2.0 Installation	4
2.1 Mechanical	4
2.2 Controls and Indicators	4
2.3 Input/Output Signals	4
2.4 Accessing and Changing Jumpers	4
2.5 Installation/Operation	5
2.5.1 Local Operation	5
2.5.2 Frequency Setting, Frequency Mode	6
2.5.3 Selecting High, Low Side LO, 70 or 140 MHz Operation	7
2.5.4 Frequency Setting, Channel Mode	7
2.5.5 Rremote Operation	8
2.5.6 Remote Control DOS Program	9
3.0 Circuit Description	10
3.1 Block Diagram Description	10
3.2 Controller Operation for 2004	11
3.2.1 General	11
3.2.2 Frequency Setting, Frequency Mode	12
3.2.3 Frequency Setting, Channel Mode	12
3.2.4 Output Attenuator Setting	12
4.0 2003/2004 1-2 GHz, Block Diagram	13
5.0 Environmental Use Information	14

WARRANTY - The following warranty applies to all Cross Technologies, Inc. products.

All Cross Technologies, Inc. products are warranted against defective materials and workmanship for a period of one year after shipment to customer. Cross Technologies, Inc.'s obligation under this warranty is limited to repairing or, at Cross Technologies, Inc.'s option, replacing parts, subassemblies, or entire assemblies. Cross Technologies, Inc. shall not be liable for any special, indirect, or consequential damages. This warranty does not cover parts or equipment which have been subject to misuse, negligence, or accident by the customer during use. All shipping costs for warranty repairs will be prepaid by the customer. There are not other warranties, express or implied, except as stated herein.

CROSS TECHNOLOGIES, INC.

6170 Shiloh Road • Alpharetta, Georgia 30005 • (770) 886-8005 • www.crosstechnologies.com

MODEL 2004, 2004R UP CONVERTER, 950-2050 MHz

SECTION 1.0 GENERAL

1.1 Equipment Description- The 2004 takes a 70 MHz IF signal and converts it to 950 to 2050 MHz in 1MHz steps with a high side 1020 to 2120 MHz LO. Over a limited frequency range, the 2004 also operates with a 140 MHz input (950 - 1980 MHz out with high side LO; 1160 - 2050 MHz out with low side LO) and 70 MHz in with low side LO (1090 - 2050 MHz out). The IF carrier input is mixed with a synthesized 1020 - 2120 MHz local oscillator signal. The output frequency is selected using up and down tune push button switches which command the microprocessor to control the synthesized oscillator. A red LED lights when the PLL is unlocked and this alarm signal goes to an open drain FET output. A yellow LED indicates remote operation. The output of the mixer is applied to the output switched attenuator providing output levels of nominally -35dBm, -55dBm, or -75dBm with -10 dBm in. The **2004R** is the rack mount version of the 2004.

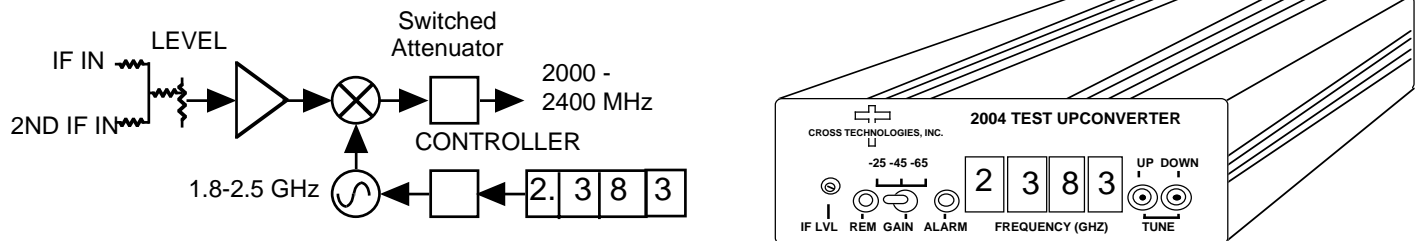

FIGURE 1.1 2004 Agile Upconverter Block Diagram and Front Panel

1.2 Technical Characteristics

TABLE 1.0 2004 UP CONVERTER SPECIFICATIONS

<u>Characteristics</u>	<u>Specifications*</u>		
Input Characteristics			
Input Impedance/RL	75 Ω /15db		
Frequency	70 or 140 MHz center		
Input Level	-20 to -10 dBm		
Input 1dB Compression	+5 dBm		
Output Characteristics			
Impedance/RL	75 Ω /10db		
Frequency Band	950 to 2050 MHz (70 MHz IF, high side LO)		
Level	selectable -35dBm, -55dBm, or -75dBm with -10dBm in		
Channel Characteristics			
Gain	Selectable -25, -45 dB, -65 dB ±3 dB		
Spurious Response	NA; output not filtered		
Frequency Response	±3 dB, 950*2050 MHz, @-25, -45 gain; ±0.5 dB, any 10 MHz increment		
Synthesizer Characteristics			
Frequency Accuracy	±25 kHz maximum		
Frequency Step	1.0 MHz minimum		
Phase Noise @ Freq	10kHz	100kHz	1MHz
dBC/Hz	-80	-90	-100

Controls

Frequency Selection	Push Button switches w/direct frequency readout
Output Level	Potentiometer and Toggle switch

Indicators

PLL Alarm	Red LED (with FET open drain)
Remote	Yellow LED

Other

RF, IF Connectors	BNC, female
Size, Bench Top	4.7" wide X 1.75" high X 12.5" deep
Size, Rack Mount (-R)	19 inch standard chassis 1.75"high X 13.0" deep (Optional)
Power	120 ± 10% VAC, 60Hz, 20 watts max, wall mount power supply

Model 2004-01 No power supply, requires 2001-01 Universal Power Supply, 100-240 ±10% VAC, 60Hz, 20 watts max. (not included)

*Specifications subject to change without notice

2.0 Installation

2.1 Mechanical - The 2004 is packaged in an aluminum extrusion. The 2004 is mounted on a 1 3/4" X 19" panel that can be mounted to a rack using the 4 holes at the ends. Both units derive $\pm 15V$ from the wall power supply or an external regulated power supply such as the Cross Technologies, Inc. model 2000-01. See Figure 2.1.

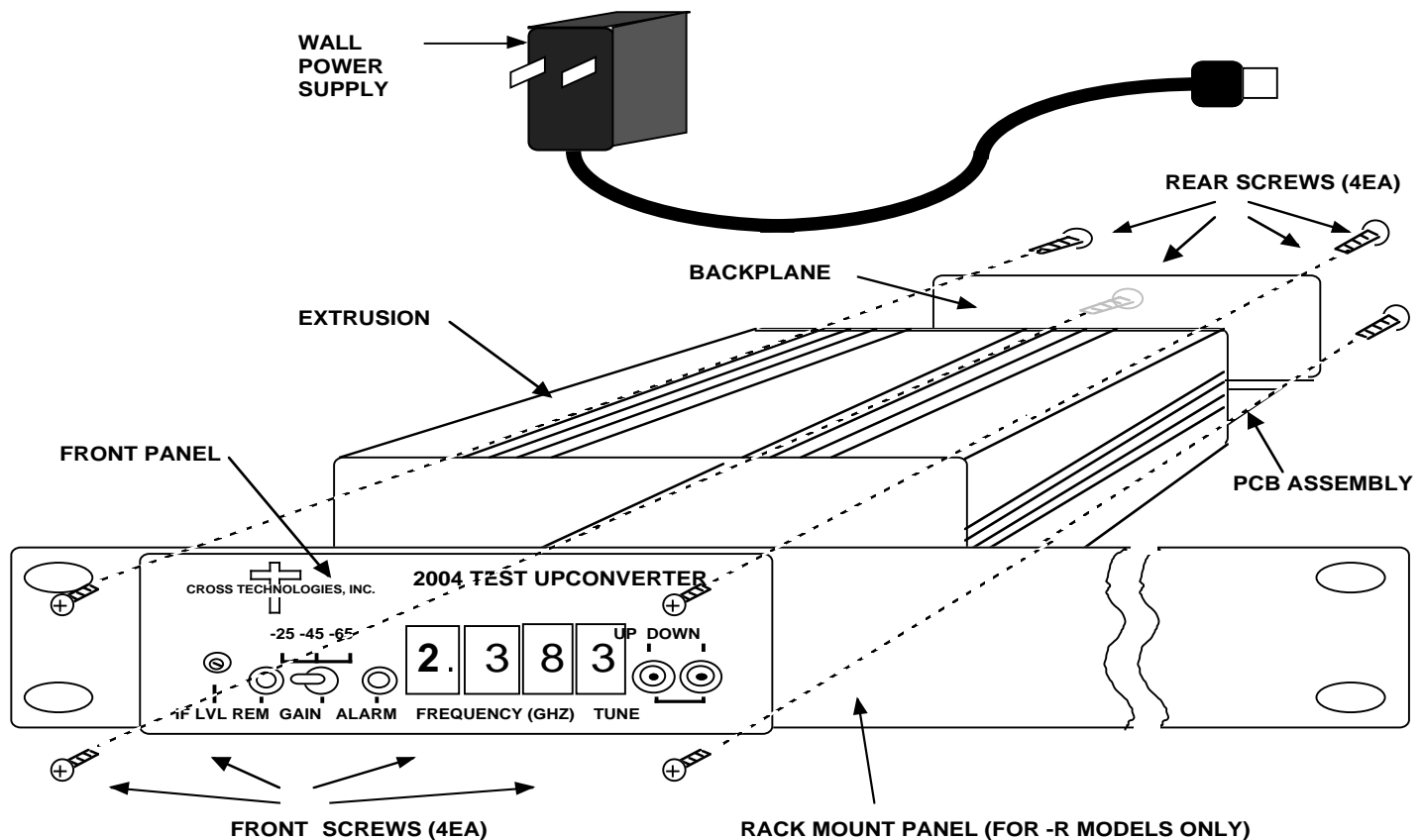

FIGURE 2.1 SERIES 2000 ASSEMBLY DRAWING

2.2 Controls and Indicators - Figure 2.2 shows front panel controls and indicators.

2.3 Input / Output Signals - Figure 2.3 shows the input and output signals to the 2004.

2.4 Accessing and Changing On-Card Jumpers and Controls - Figure 2.4 shows jumpers (with factory settings) and other on-card controls. To remove the printed circuit board (PCB) from the extrusion for access to the jumpers and controls:

- 1.) Remove four (4) **rear panel screws** (see Figure 2.1).
- 2.) **Gently** pull the backplane and PCB assembly completely out of the extrusion.
- 3.) With the **wall power supply disconnected**, move jumpers to the desired positions (Figure 2.4).
- 4.) **To set Channel frequencies** apply power via wall power supply and program frequencies (see 2.5.4).
- 5.) **Always remove power** when installing the PCB in to the extrusion. Make sure the shield goes in the lower channel and the PCB in the next channel above that in the extrusion.
- 6.) **Gently** push the backplane and PCB assembly completely in to the extrusion so the front panel controls go through the front panel.
- 7.) Install four (4) **rear panel screws**.

2.5 Installation / Operation -

2.5.1 Local Operation -

- 1.) If required, check that on-card jumpers are set to the desired positions (Figure 2.4)
- 2.) Connect the wall power supply to the 2004 and the wall power supply to 115 VAC, 60 Hz (Figure 2.1)
- 3.) Connect a -10dBm signal to IF #1 In (Figure 2.1, Figure 2.3)
- 4.) Connect a -10dBm signal to IF #2 In (Figure 2.1, Figure 2.3). If this port is not used it must be terminated in 75Ω by connecting on-card jumper JP4 in the 2-3 position (Figure 2.4).
- 5.) Set the desired frequency by pushing SW3 or SW4. If numbers 0 to 9 appear when pushing SW3 or SW4, the 2004 is set for the channel mode (with on-card jumper JP4, Figure 2.4). See section 2.5.2 for frequency setting information.
- 6.) Set SW1 for the desired gain (Figure 2.2).
- 7.) Be sure DS1 and DS6 are off (Figure 2.2).
- 8.) If needed, R52 can be adjusted (Figure 2.2) for input signals that are different than -10 dBm (-5 to -15 dBm). Note that this adjusts the levels of both IF #1 and IF #2 and uncalibrates the 2004 from its -10 dBm input setting.

PLEASE NOTE! - IF USING THE IF#2 INPUT, if jumper JP4 is in 2-3 (75Ω termination) the signal path for IF#2 is OPEN! If JP2 is in 1-2 (IF#2 active), the IF#2 input MUST be externally terminated either by the IF#2 source or an external 75Ω termination!

2.5.2 Frequency Setting, Frequency Mode -

In this mode, the frequency is selected by pushing the up and down switches (SW3, SW4) on the front panel until the desired frequency is indicated on the front on the display. The frequency displayed is the desired output frequency with the IF center frequency input. EEROM U3 stores the last frequency set so in the event of power failure the upconverter will go to the frequency it was set to prior to the power outage. The front panel frequency setting switches increment or decrement the frequency in 1.0 MHz steps at approximately a 5 step per second rate. If the switch remains depressed for approximately ten steps, the rate increases by a factor of ten. There is no muting of the output carrier during frequency selection.

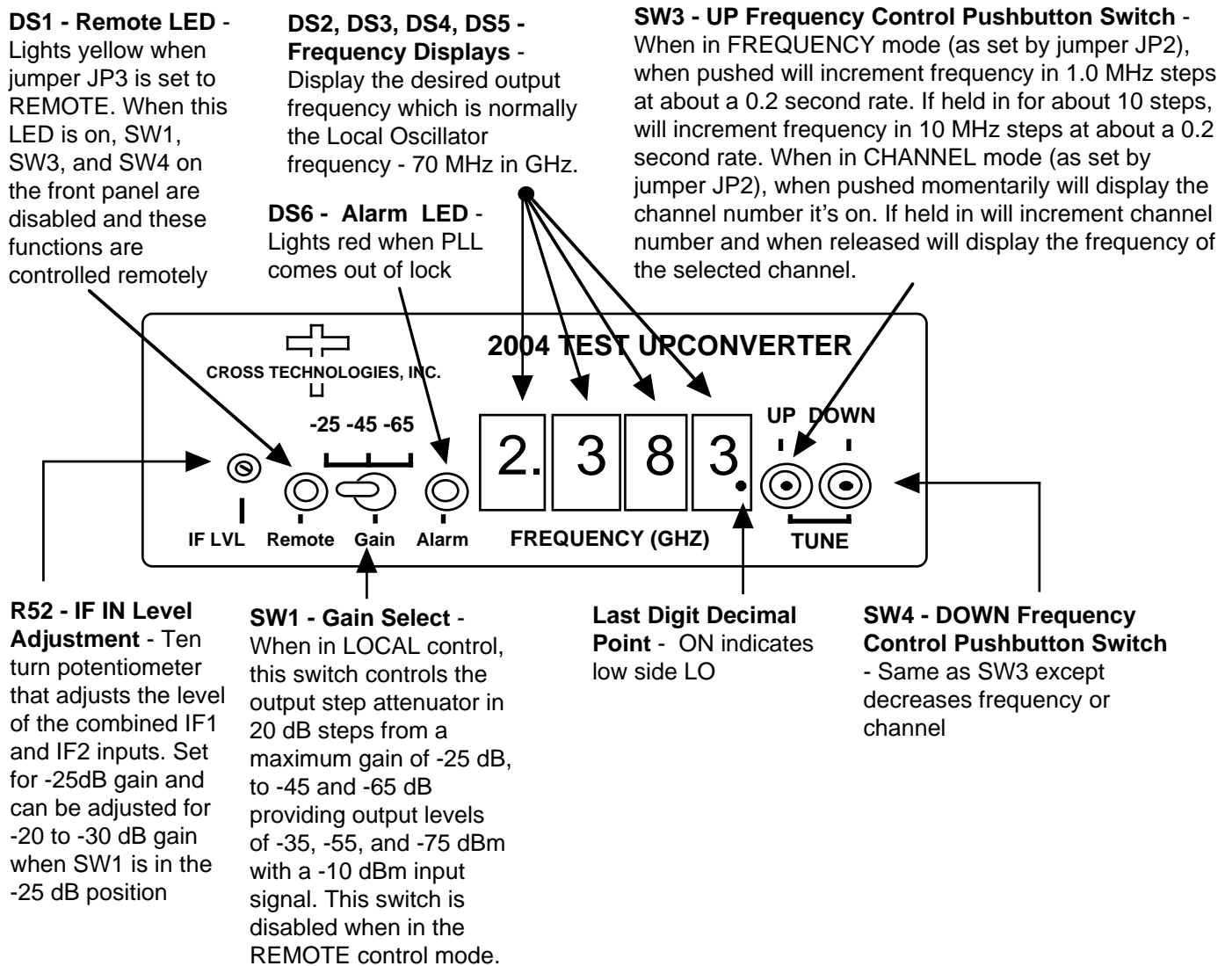

FIGURE 2.2 2004 Front Panel Controls and Indicators

2.5.3 Selecting High Side LO, Low Side LO, 70MHz or 140 MHz Input - The 2004 operates over its full 2000 to 2400 MHz range with high side or low side LO and 70 or 140 MHz input. Normally, LNB's use high side LO for C-band and low side LO for Ku-band so if more than one carrier is summed in to the 2004 the math will work out easier using high side LO for C-band systems and low side LO for Ku-band systems. Also, note that there will be a spectrum inversion of the input IF modulation with the high side LO. The following table shows the LO frequencies for the various configurations. The PLL will alarm if you try to operate the 2004 outside the allowable frequency range shown.

LO-Side	IF (MHz)	LO Range (MHz)	Allowable Frequency Range (MHz)
HIGH	70	2070-2470	2000-2400
LOW	70	1930-2330	2000-2400
HIGH	140	2140-2540	2000-2400
LOW	140	1860-2260	2000-2400

To select High Side LO, Low Side LO, 70MHz or 140 MHz Input proceed as follows

- 1.) The **factory set** mode is **70 MHz IF, high side LO**.
- 2.) **To go to the change modes function**, simultaneously **press and release both the Up and Down pushbutton** switches (SW3 and SW4, see Figure 2.2). The current IF frequency is shown on the displays.
- 3.) Use **either the Up or Down switch** to select **one of the 4 modes**. The IF frequency is shown on the displays.
Low side LO is indicated when the least significant digit's **decimal point is illuminated**.
High side LO is indicated when the least significant digit's decimal point is off.
- 4.) **When there is no front panel switch activity for 5 seconds** the last mode selected is the current mode. If a **low side LO mode** is selected the least significant digit's **decimal point remains on** as a reminder.
- 5.) **To check the selected IF frequency**, momentarily **press and release both the Up and Down pushbutton** switches (SW3 and SW4, see Figure 2.2)

2.5.4 Frequency Setting, Channel Mode - A second tuning mechanism is channel selection. This is accomplished when the on board three-pin jumper (JP2) (Figure 2.4) is set to the "channel" position.

Ten preset channels (0-9) can be selected as follows:

1. The 2004 PCB is removed from the extrusion (see section 2.4 for instructions) to access the channel selecting decimal switch (SW5) and the push to program switch (SW2) (Figure 2.4).
 With the display mode jumper (JP2) set in the frequency mode, the frequency set switches (SW3,SW4) are pushed to the frequency desired (Figure 2.2).
2. The decimal switch (SW5) is set to the channel number desired to be programmed (Figure 2.4).
3. Push programming button (SW2) to program the displayed frequency into that channel number (Figure 2.4).
4. The above steps are repeated for any additional channels that are desired to be programmed.
5. When finished, set JP2 (Figure 2.4) in the "Channel" position if this tuning mechanism is desired.

At the factory, channels zero through nine are programmed from 2000 to 2400 MHz in 50 MHz steps. When in the remote mode, either frequencies or channel numbers can be provided, but programming of the channels can only be done locally. The frequency display (DS2, DS3, DS4, DS5) in the channel mode displays the current channel number selected when SW3 or SW4 is pushed, and, if the switch is held for more than 2 seconds, the channel numbers are incremented or decremented depending on which button is pushed. The display indicates zero through nine for channel number, and, when the desired channel is selected and the button is released for one to two seconds, the frequency of that channel is shown on the frequency display and this frequency display remains until switch SW3 or SW4 is pushed again.

J5 - IF #2 Input - The second IF input. If not used can be terminated in 75Ω with on-card jumper JP4. If JP4 is in TERMINATE position (FACTORY setting) the **IF#2 signal path is open**. This is a 75Ω, BNC input at normally -10 to -20 dBm levels. The RF output of -35 dBm occurs with -10 dBm in as set at the factory and this gain is also adjusted when front panel pot R52 is adjusted.

J6 - 1-2 GHZ RF OUT - The desired RF output. This is an unfiltered output and will also contain the LO, LO ± IF, and other mixer products. This is a 75Ω, BNC output at normally -35 to -75 dBm levels.

J3 - REMOTE & MONITOR - DB9 female connector
PIN - FUNCTION

- 1 - Ground
- 4,6,7,8 - No Connection
- 3- Remote Control Data In - RS232C, 9600 B/s ASYNC (8N1) data from computer.
- 2- Remote Control Data Out - RS232C, 9600 B/s ASYNC (8N1) data to computer
- 5 - Ground
- 9 - PLL Alarm FET open drain output - Provides a short to ground (100 ma max) if a PLL alarm occurs.

J4 - IF #1 Input - The main IF 70 MHz input. This is a 75Ω, BNC input at normally -10 to -20 dBm levels. The RF output of -35 dBm occurs with -10 dBm in as set at the factory and this gain can be adjusted by front panel pot R52.

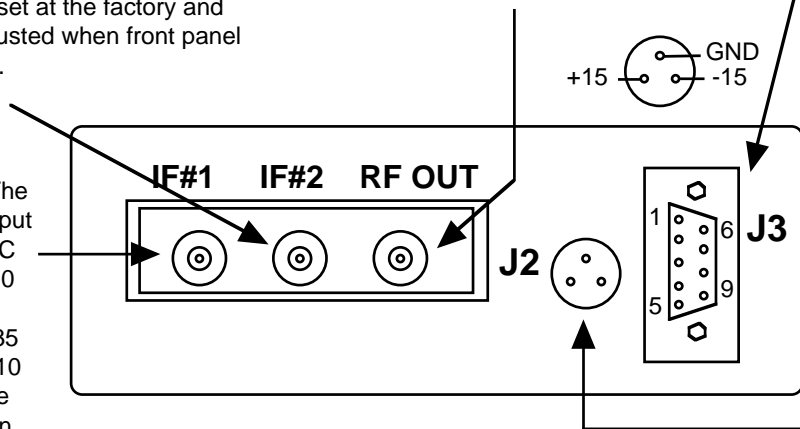

J2 - DC IN - The +15 VDC AND -15 VDC regulated DC voltage from the wall power supply

FIGURE 2.3 2003 and 2004 Inputs and Outputs

2.5.5 Remote Operation - Frequency control and setting of the output attenuator can be remotely commanded from an external (not supplied) PC using a simple DOS program. To place the 2004 in the Remote mode, place on-card jumper JP3 in the REMOTE (pins 2-3) position (Figure 2.4) and observe yellow LED DS1

(Figure 2.2) is on. Serial ASYNC (8N1) data is received via RS232C receiver U4 and sent via RS232C transmitter U13 at a 9.6kB/s data rate. When in the remote mode, either frequencies or channel numbers can be provided, but programming the frequencies of the channels can only be done locally. When in the remote control mode, the selection of U6 and consequently the output attenuator U16, U24 is controlled through the remote serial port disabling the function of front panel attenuator control switch SW1 and providing gain selection of -25 dB, -45 dB or -65 dB.

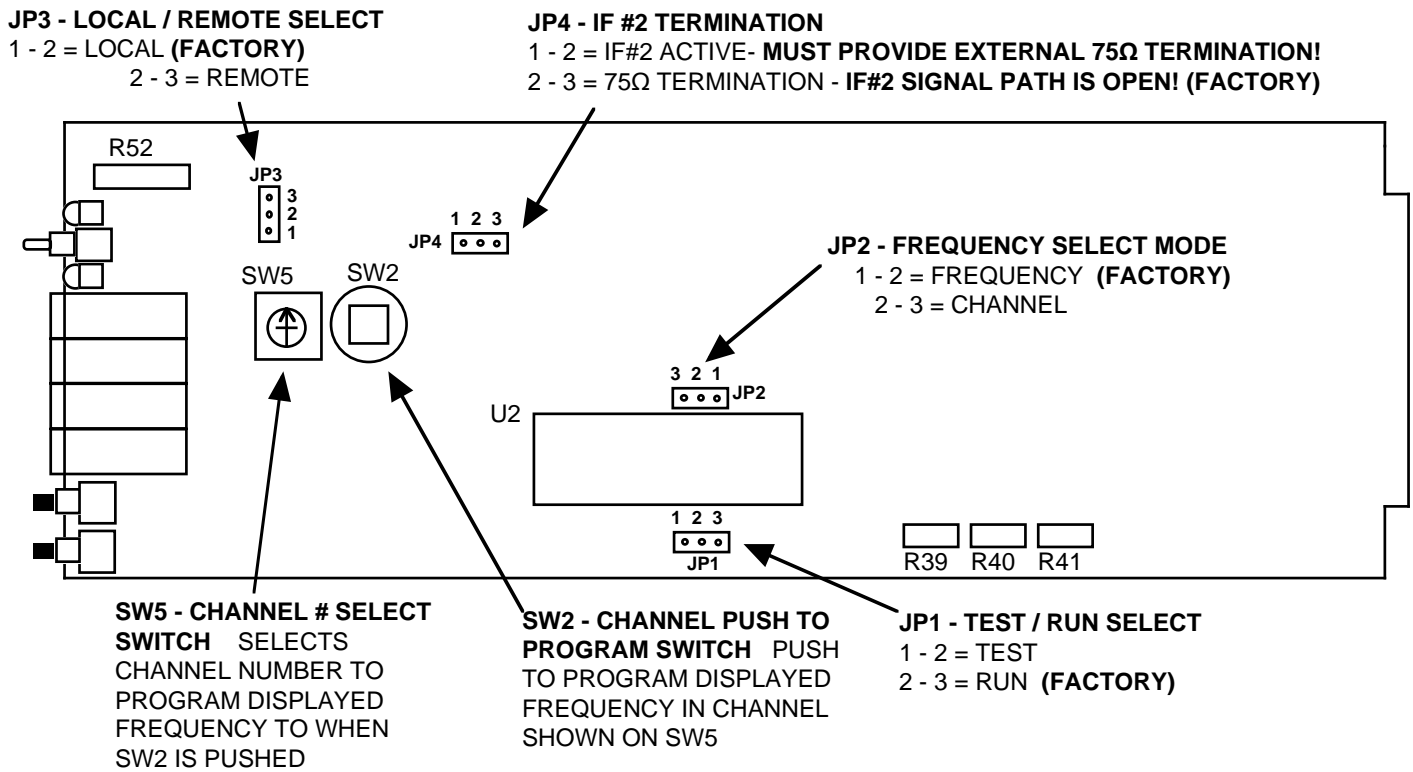

FIGURE 2.4 2003 and 2004 On-Card Jumpers and Controls (See Section 2.4 for instructions on removing the PCB from the extrusion)

2.5.6 Remote Control DOS Program - The 2004 remote control program (REMOTE.EXE, diskette supplied with the 2004) runs on an IBM compatible computer under DOS. The user is prompted to select one of three possible functions, which are:

1. Set Frequency
2. Set Channel
3. Set Gain

When Set Frequency is selected, the up arrow and down arrow keys are used to increase or decrease the 2004's output frequency in 1.0 MHz increments.

When Set Channel is selected, the up arrow and down arrow keys are used to select one of ten possible channels. The frequency of each channel must be programmed locally, as described in section 2.5.4.

When Set Gain is selected, the up arrow and down arrow keys are used to select one of three possible gains.

The remote control program sends commands to the 2004 through pin 3 of the DB9 connector, J3 (Figure 2.3). Pin 3 is an RS-232 serial port set to accept 8N1 formatted data. Each command sent to the 2004 consists of an instruction byte followed by one or two bytes of data. The 2004 acknowledges receiving and successfully executing each remote control command by sending an **acknowledge byte** (9600 baud, 8N1 format) through pin 2 of the DB9 connector, J3.

The instruction byte to set output frequency is 0A (hex). This byte must be followed by two data bytes of the desired output frequency in BCD format. The following list shows examples of this.

<u>Output Frequency</u>	<u>Control Bytes (Acknowledge byte = 06 (hex))</u>
2000 MHz	0A (hex), 20 (hex), 00 (hex)
2167 MHz	0A (hex), 21 (hex), 67 (hex)
.	.
.	.
2400 MHz	0A (hex), 24 (hex), 00 (hex)

The instruction byte to set channel is 0B (hex). This byte must be followed by a data byte that selects one of 10 possible channels. The following list shows examples of this.

<u>Channel</u>	<u>Control Bytes (Acknowledge byte = 07 (hex))</u>
0	0B (hex), 00 (hex)
1	0B (hex), 01 (hex)
.	.
.	.
9	0B(hex), 09 (hex)

The instruction byte to set gain is 0C (hex). This byte must be followed by a data byte that selects one of 3 possible gains. The following list describes the relationship between the control bytes and gain setting.

<u>Gain</u>	<u>Control Bytes (Acknowledge byte = 08 (hex))</u>
-25 dB	0C (hex), 01 (hex)
-45 dB	0C (hex), 02 (hex)
-65 dB	0C (hex), 03 (hex)

3.0 Circuit Description

3.1 Block Diagram Description - 2004 (Figure 3.1) - The 70 MHz input (J4) carrier first goes through a resistive summing network (R49, R50, R51) which allows insertion of another carrier or noise on the 2nd IF In, J5. If the 2nd IF In port is not used it can be internally terminated by strapping JP4 to connect R102 to this input (**NOTE: This opens the signal path for the 2nd IF In**). The signal then goes through a lowpass filter consisting of L1, C33 and C34 which cuts off at approximately 200 MHz. The signal next goes to a variable attenuator, R52, R53, R54, which is adjusted to provide for level input variations of -15 to -5 dBm in. Amplifier U15 provides +13 dB gain. The signal then goes to mixer A1 which receives the LO generated by VCO A2 and provides the LO \pm IF and LO unfiltered output.

This signal next goes through 3.5 dB attenuator R66, R67, R68, R103 and then to voltage variable attenuator U16, U24 which is driven by DC voltages applied through FET switch, U6. These three DC voltages determine the minimum, middle and maximum attenuation of this attenuator which provides a 40 dB attenuation range in

20 dB increments to allow testing a receiver at the low, mid and high ends of its dynamic range. The signal next goes to output buffer amplifier U17 which provides +10 dB gain and to the output BNC connector J6 via 3.5 dB attenuator R70, R71, R72, R104. IF input connectors J4 and J5 are also BNC.

Commands for the phase lock loop IC, U18, are provided serially from microprocessor U2 which receives serial RS232C commands from an external (not supplied) PC via RS232C receiver IC, U4. Microprocessor U2 can send serial RS232C commands to an external PC via RS232C transmitter IC, U13. Frequency control and setting of the output attenuator is provided by microprocessor U2 and can be remotely commanded from an external (not supplied) PC using a simple DOS program.

Microprocessor U2 uses its internal oscillator controlled by the 4.9152 MHz crystal Y1. Crystal oscillator A3 provides the 25 MHz reference frequency for the synthesizer U18. U23, Q4, and associated circuitry generate an open collector alarm when phase lock is lost. U19 provides +30 VDC for the loop amplifier U22. Q2 and Q3 provide low noise regulated voltages for A2 and U18. U1 is a watch dog timer for microprocessor U2. IC's U7, U8, U9, U10, U11, U14 provide multiplexing and strobing of displays DS2, DS3, DS4, DS5.

3.2 Controller Operation for 2004 Upconverter

3.2.1 General - The controller consists of a microprocessor and associated circuitry which receives inputs from

- a) the front panel frequency set switches (SW3, SW4),
- b) the front panel attenuator step switch (SW1),
- c) the on card display mode jumper (JP2),
- d) the on card channel programming decimal switch (SW5),
- e) the on card channel programming "push to program" switch (SW2), and
- f) the on card local / remote control mode jumper (JP3)

The controller provides command signals to the

- a) phase lock loop IC (U18),
- b) output attenuator control switch (U6), and
- c) the front panel frequency display (DS2, DS3, DS4, DS5).

In addition, when in the remote control mode, the microprocessor U2 accepts a serial data stream which is generated by a simple DOS program (by an external, not provided, PC) that selects the frequency and the gain. Serial data is received via RS232C receiver U4 and sent via RS232C transmitter U13. The following provides additional detail.

3.2.2 Frequency Setting, Frequency Mode - The frequency is selected either by pushing the up and down switches (SW3, SW4) on the front panel until the desired frequency is indicated on the front on the display or, if set to the channel mode, the up and down switches select one of ten preset channels that have been programmed in. The frequency displayed is the desired output frequency which is factory set as the local oscillator (LO) minus the 70 MHz input frequency. EEROM U3 stores the last frequency set so in the event of power failure the upconverter will go to the frequency it was set to prior to the power outage. The front panel frequency setting switches increment or decrement the frequency in 1.0 MHz steps at approximately a 5 steps per second rate. If the switch remains depressed for approximately ten steps, the rate increases by a factor of ten. There is no muting of the output carrier during frequency selection.

3.2.3 Frequency Setting, Channel Mode - A second tuning mechanism is channel selection. This is accomplished when the on board, but not front panel accessible, three-pin jumper (JP2) (Figure 2.4) is set to the “channel” position. Ten preset channels (0-9) can be selected as follows:

1. The 2004 PCB is removed from the extrusion (see section 2.4 for instructions) to access the channel selecting decimal switch (SW5) and the push to program switch (SW2) (Figure 2.4). With the display mode jumper (JP2) set in the frequency mode, the frequency set switches (SW3,SW4) are pushed to the frequency desired (Figure 2.2).
2. The decimal switch (SW5) is set to the channel number desired to be programmed (Figure 2.4).
3. Push programming button (SW2) to program the displayed frequency into that channel number (Figure 2.4).
4. The above steps are repeated for any additional channels that are desired to be programmed.
5. When finished, set JP2 (Figure 2.4) in the “Channel” position if this tuning mechanism is desired.

At the factory, channels zero through nine are programmed from 2000 to 2400 MHz in 50 MHz steps. When in the remote mode, either frequencies or channel numbers can be provided, but programming of the channels can only be done locally.

The frequency display (DS2, DS3, DS4, DS5) in the channel mode displays the current channel number selected when SW3 or SW4 is pushed, and, if the switch is held for more than 2 seconds, the channel numbers are incremented or decremented depending on which button is pushed. The display indicates zero through nine for channel number, and, when the desired channel is selected and the button is released for one to two seconds, the frequency of that channel is shown on the frequency display and this frequency display remains until switches SW3 or SW4 are pushed again.

3.2.4 Output Attenuator Setting - When in the local mode, the microprocessor reads the front panel attenuator switch (SW1) and depending on its setting, will send a command to U6 which selects a DC voltage for U16, U24 that determines the attenuator setting. When in the remote control mode, the selection of U6 and consequently the output attenuator U16, U24 can be controlled through the remote serial port and SW1 is disabled.

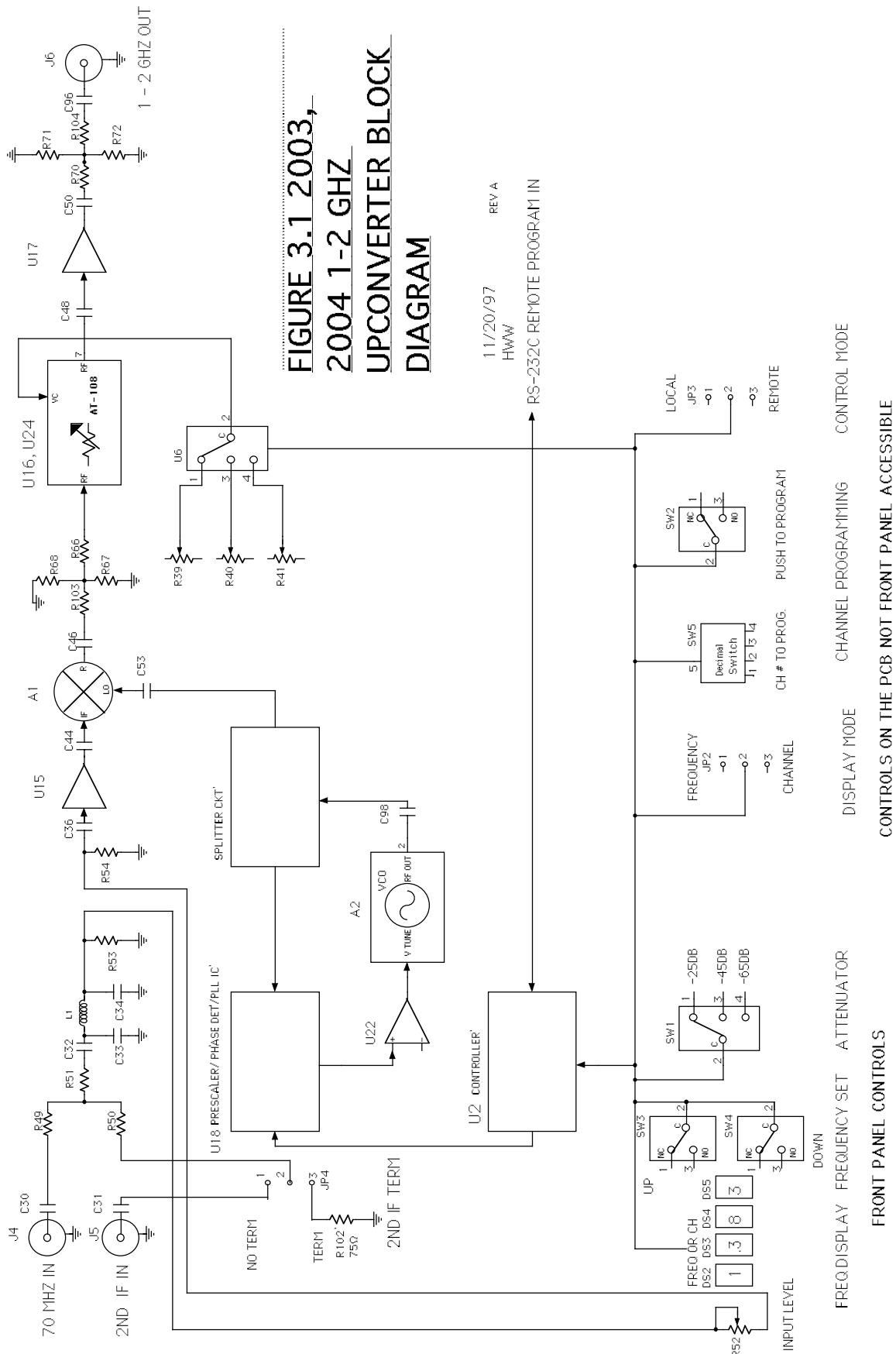

**FIGURE 3.1 2003,
2004 1-2 GHz
UPCONVERTER BLOCK
DIAGRAM**

11/20/97
HWW
REV A

RS-232C REMOTE PROGRAM IN

FREQ/DISPLAY FREQUENCY SET ATTENUATOR DISPLAY MODE CHANNEL PROGRAMMING CONTROL MODE
FRONT PANEL CONTROLS CONTROLS ON THE PCB NOT FRONT PANEL ACCESSIBLE

5.0 Environmental Use Information

- A. **Rack-Mounting** - To mount this equipment in a rack, please refer to the installation instructions located in the user manual furnished by the manufacturer of your equipment rack.
- B. **Mechanical loading** - Mounting of equipment in a rack should be such that a hazardous condition does not exist due to uneven weight distribution.
- C. **Elevated operating ambient temperature** - If installed in a closed or multi-unit rack assembly, the operating ambient temperature of the rack may be greater than room ambient temperature. Therefore, consideration should be given to Tmra.
- D. **Reduced air flow** - Installation of the equipment in a rack should be such that the amount of air flow required for safe operation of the equipment is not compromised. Additional space between unit may be required.
- E. **Circuit Overloading** - Consideration should be given to the connection of the equipment to the supply circuit and the effect that overloading of circuits could have on over current protection and supply wiring. Appropriate consideration of equipment name plate rating should be used, when addressing this concern.
- F. **Reliable Earthing** - Reliable earthing of rack-mounted equipment should be maintained. Particular attention should be given to supply connections other than direct connection to the Branch (use of power strips).
- G. **Top Cover** - There are no servicable parts inside the product so, the Top Cover should not be removed. If the Top Cover is removed the ground strap and associated screw **MUST BE RE-INSTALLED** prior to Top Cover screw replacement. **FAILURE TO DO** this may cause **INGRESS** and/or **EGRESS** emission problems.



6170 Shiloh Road
Alpharetta, Georgia 30005

(770) 886-8005
FAX (770) 886-7964
Toll Free 888-900-5588

WEB www.crosstechnologies.com
E-MAIL info@crosstechnologies.com

Printed in USA