

Instruction Manual

Model 1582-125L

1:1 Switch

February 2020, Rev. A

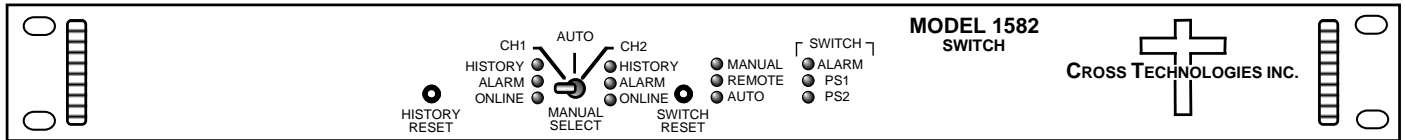

Data, drawings, and other material contained herein are proprietary to Cross Technologies, Inc., but may be reproduced or duplicated without the prior permission of Cross Technologies, Inc. for purposes of operating the equipment. Printed in USA.

When ordering parts from Cross Technologies, Inc., be sure to include the equipment model number, equipment serial number, and a description of the part.



6170 Shiloh Road
Alphabet, Georgia 30005

(770) 886-8005
FAX (770) 886-7964
Toll Free 888-900-5588

WEB: www.crosstechnologies.com
E-MAIL: info@crosstechnologies.com

INSTRUCTION MANUAL

MODEL 1582-125L, 1:1 Switch, M&C Monitor & Channel Select

<u>TABLE OF CONTENTS</u>	<u>PAGE</u>
Warranty	2
1.0 General	3
1.1 Equipment Description	3
1.2 Technical Characteristics	4
1.3 Monitor and Control Interface	6
1.4 M&C Commands	7
2.0 Installation	11
2.1 Mechanical	11
2.2 Input and Output Signals	12
2.3 Controls and Indicators	13
2.4 Operation	14
3.0 Environmental Use Information	17

WARRANTY - The following warranty applies to all Cross Technologies, Inc. products.

All Cross Technologies, Inc. products are warranted against defective materials and workmanship for a period of one year after shipment to customer. Cross Technologies, Inc.'s obligation under this warranty is limited to repairing or, at Cross Technologies, Inc.'s option, replacing parts, subassemblies, or entire assemblies. Cross Technologies, Inc. shall not be liable for any special, indirect, or consequential damages. This warranty does not cover parts or equipment which have been subject to misuse, negligence, or accident by the customer during use. All shipping costs for warranty repairs will be prepaid by the customer. There are not other warranties, express or implied, except as stated herein.



6170 Shiloh Road
Alphabet, Georgia 30005

(770) 886-8005
FAX (770) 886-7964
Toll Free 888-900-5588

WEB: www.crosstechnologies.com
E-MAIL: info@crosstechnologies.com

1582-125L 1:1 Switch, 0.95-2.15 GHz, 2PDT, M&C Monitor and Channel Select

1.0 General

The 1582-125L 1:1 Switch provides 2PDT Auto, Manual or Remote (M&C) latched relay switching between CH1 and CH2, DC - 2.5 GHz RF signals. The M&C provides monitoring of all parameters, Switch and History Reset, and Channel Selection (when in Auto mode only). Alarm conditions on CH1 and CH2 are either a contact closure to ground or an open (selectable by a rear panel DIP switch). Auto has three modes:

Auto - CH1 PRIME; The CH1 preferred mode - switches from CH1 to CH2 only if CH1 alarms and CH2 is good. The unit switches back to CH1 when CH1 is no longer in alarm or both CH1 and CH2 are alarmed.

Auto - LATCH2; Latch to CH2 mode - switches from CH1 to CH2 if CH1 alarms and CH2 is good and stays in CH2 regardless of CH1 or CH2 alarm conditions until reset to CH1 by the front panel Switch Reset switch or M&C command.

Auto - MIN. SW; Minimum Auto switching mode - switching occurs if the active channel (set by the front panel Manual Select switch or M&C command) alarms and the other channel is clear. It switches back if this channel then alarms and the other is clear.

When power is lost, the current latched state remains selected. Front panel LEDs indicate CH1 and CH2 alarms, Remote or Manual mode, and redundant power supplies on. Rear panel DIP switches set alarm polarity (NO or NC for alarm), M&C interface, and Auto modes (CH1 PRIME, LATCH2, or MIN. SW). The front panel switch selects the signal path in the Manual mode or selects AUTO switching. The RS232 or RS422/485 M&C (Ethernet optional) monitors switch positions, LED and alarm status, and selects the RF switch position (when in Auto mode only). A contact closure to ground indicates an internal fault condition or loss of power. Connectors are BNC for RF signals and DB9 for M&C and alarm input and output contact closures. The 1RU chassis has separately fused, redundant power supplies with 100-240 \pm 10% VAC input connectors.

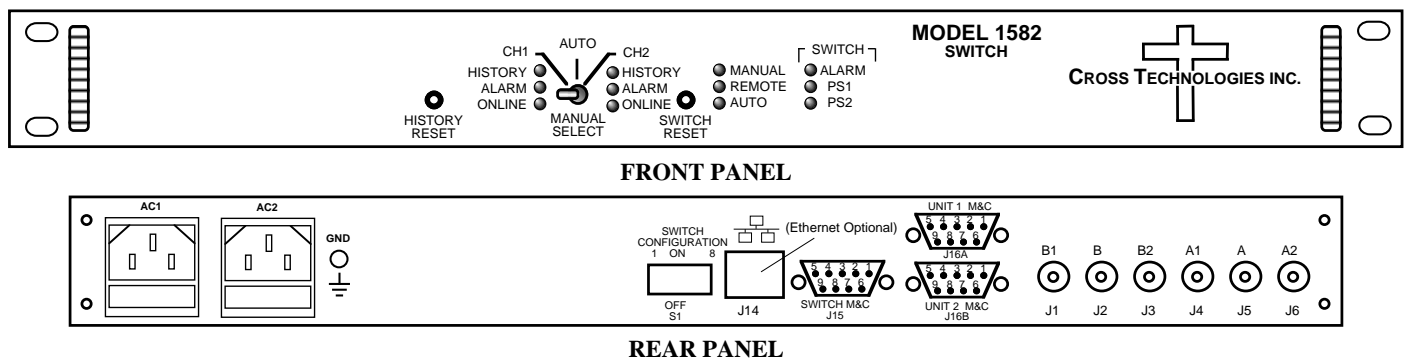

FIGURE 1.1 Model 1582-125L Front and Rear Panels

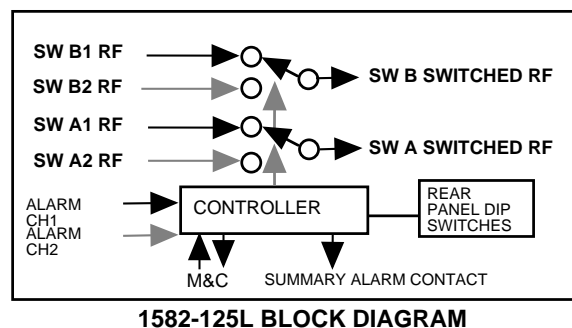

FIGURE 1.2 Model 1582-125L Switch Block Diagram

1.2 Technical Characteristics

TABLE 1.0 1582-125L 1:1 Switch, Specifications*	
IF/L-Band Switch Characteristics	
Impedance / Connectors	75Ω / BNC
Return Loss	12 dB minimum, ≥ 14 dB typical; DC to 1.5 GHz 10 dB minimum, ≥ 12 dB typical; 1.5 to 2.5 GHz
Frequency Response	≤ ±0.5 dB, 40 MHz BW, ≤ ±1 dB, 1 GHz BW
Isolation	55 dB minimum, ≥ 60 dB typical, DC to 1.5 GHz 45 dB minimum, ≥ 50 dB typical; 1.5 to 2.5 GHz
Insertion Loss	1.5 dB maximum, ≤ 1.0 dB typical; DC to 1.5 GHz 2.5 dB maximum, ≤ 2.0 dB typical; 1.5 to 2.5 GHz
Switch Time	≤ 10 milliseconds
DC Switching	30VDC, maximum; 0.5 Amps, maximum
Type, Configuration	Latching Relay, 2PDT, No Termination
Alarm and Control, M&C	
Alarm Output Signal	Form C relay: 30VDC, 0.5A maximum
M&C Interface / Baud Rate	RS232C or RS422/485, Selectable/9600 (Ethernet Optional)
Connectors, Indicators	
Auto/Manual	Front Panel Switch
Switch Reset, History Reset	Front Panel Switches or M&C
Power, Remote, Manual, Alarm	Green, Yellow, Red, Red LED - Form C contact closure, M&C
Connectors, Other	
RF, Connectors	75Ω BNC (female)
Ext. Alarms In, M&C Connector	DB9 (female)
Size	1 RU, 19 inch Standard Chassis, 1.75" high x 12.0" deep
Power	Redundant 100-240 ±10% VAC, 47-63 Hz., 20 Watts maximum Power Supplies
*10°C to 40°C; Specifications subject to change without notice.	
Cross Technologies, Inc.	

(Technical Characteristics continued on page 5...)

(Technical Characteristics continued from page 4...)

Available Options	
Remote M&C Interface	
W- 8	Ethernet
W-18	Ethernet with SNMP (and MIB) Interface
W-28	Ethernet with Direct TCP/IP Access
W-31	0 to +50 degrees C operation
Connectors/Impedance: Options	
D -	50Ω BNC
SS -	50Ω SMA
* 10°C to 40°C; Specifications subject to change without notice	
© Cross Technologies, Inc.	

1.3 Monitor and Control Interface

A) Remote Serial Interface

Protocol: RS232C, 9600 baud rate, no parity, 8 data bits, 1 start bit, and 1 stop bit.
(RS232C, RS-422, or **RS-485**)

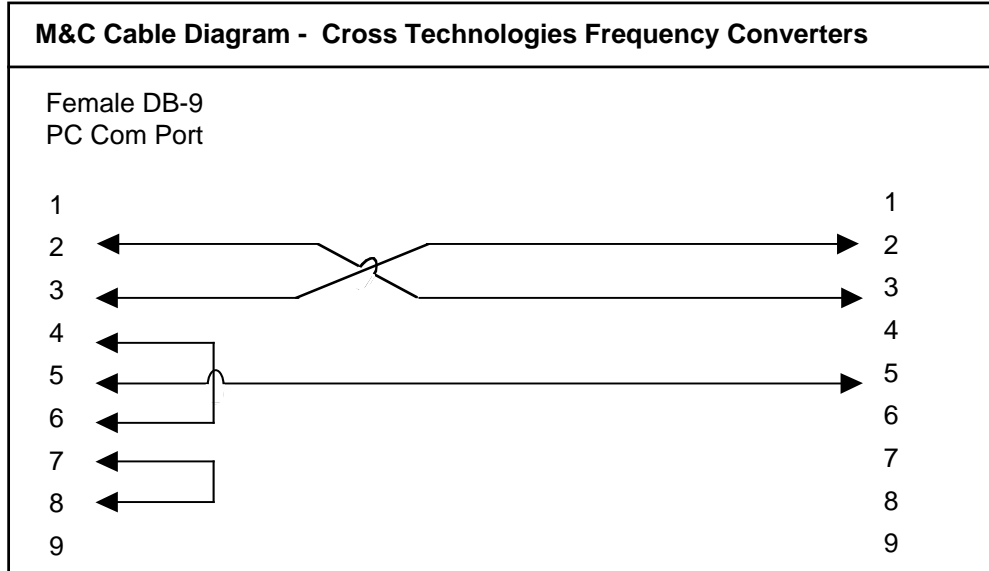

Connector: Rear panel, DB-9 Female:

J15 Pinouts (RS-232C/422/485)	
Pin	Function
1	Rx-
2	Rx+ (RS-232C)
3	Tx+ (RS-232C)
4	Tx-
5	GND
6	Alarm Relay: Common
7	Alarm Relay: Normally Open
8	Not Used
9	Alarm Relay: Normally Closed

1.4 M&C Commands

The following tables summarize the commands and status queries applicable to the 1582-125L Switch.

* **PLEASE NOTE:** The two character {aa} prefix, shown in the table below, is present **ONLY** when RS485 is selected.

Table 2.0 Model 1582-125L - M&C Remote Commands

Table 2.0: Model 1582-125L 1:1 Switch, M&C Remote Commands		
Command Function	Syntax	Command Description
Set RF Switch Position	{aaCRx}	where: aa = unit address, range = 00 to 31, only used if interface is RS485, otherwise omit R = Command Code x = desired switch position, 1 or 2. Once the switch position is selected remotely, the unit is in "Remote Mode" and the front panel remote indicator will light. The unit will remain in Remote Mode until one of the following occurs: 1. A Switch Reset command ({CB}) is issued. 2. The front panel Switch Reset button is pressed. If the switch is already in manual mode (i.e, the front panel toggle switch is in the CH1 or CH2 position) then the unit will ignore this command. example: {CR2}
		Will (remotely) set the switch to CH2. The unit will ignore this command if the unit is in manual mode. The unit will reply with the '<' character if the command is not processed because the unit is in Manual Mode. The unit will reply with the '>' character if the command is successfully processed.
Switch Reset	{aaCB}	where: aa = unit address, range = 00 to 31, only used if interface is RS485, otherwise omit B = Command Mode This command has the same effect as pressing the front panel Switch Reset button. example: {CB}
		Will return a unit to Auto mode if it is in Remote mode. Also, this command will reset the switch position if it is currently "latched" to CH2 mode (and if CH1 is not alarmed). The unit will reply with the '>' character if the command is successfully processed.
Alarm History Reset	{aaCH}	where: aa = unit address, range = 00 to 31, only used if interface is RS485, otherwise omit H = command mode example: {CH}
		Will clear the Alarm History Status and LEDs

Table 2.0 M&C Remote Commands Continued on page 8...

1.4 M&C Commands (continued...)

Table 2.0 M&C Remote Commands Continued from page 7...

Table 2.0: Model 1582-125L, 1:1 Switch, M&C Remote Commands Continued		
Command Function	Syntax	Command Description
Set RS485 Address	{aaCXxx}	where:
		aa = unit address, range = 00 to 31, only used if interface is RS485, otherwise omit
		x = command code
		xx = unit address, range = 00 to 31
		example: {CX12}
		Will set the unit's RS485 address to 12

1.5 M&C Queries

Table 2.1 Model 1582-125L - M&C Status Request/Inquiries

Table 2.1: Model 1582-125L 1:1 Switch M&C Status Request/Inquires		
Command Function	Syntax	Command Description
Get Switch State	{aaSZ}	Returns; {aaSZbcdefgh}
		where:
		aa = unit address, range = 00 to 31, only used if interface is RS485, otherwise omit
		Z = Command Code
		b = Switch Position: 1 or 2
		c = Switch Mode: 'M' if in Manual Mode, 'R' if in Remote Mode, and 'A' if in Auto Mode.
		The unit will append the '>' character if the command is successfully processed.
Get Channel 1 Alarm Status	{aaS1}	Returns: {aaS1bc}
		where:
		aa = unit address, range = 00 to 31, only used if interface is RS485, otherwise omit
		1 = Command Code
		b = CH1 alarm status: 0 if alarm is off, 1 is alarm is on
		c = CH1 alarm history status: 0 if no alarm history, i if an alarm occurred
		The unit will append the '>' character if the command is successfully processed.
Get Channel 2 Alarm Status	{aaS2}	Returns: {aaS2bc}
		where:
		aa = unit address, range = 00 to 31, only used if interface is RS485, otherwise omit
		2 = Command Code
		b = CH2 alarm status: 0 if alarm is off, 1 is alarm is on
		c = CH2 alarm history status: 0 if no alarm history, i if an alarm occurred
		The unit will append the '>' character if the command is successfully processed.
Get Auto Switching Mode	{aaSA}	Returns: {aaSAx}
		where:
		aa = unit address, range = 00 to 31, only used if interface is RS485, otherwise omit
		A = Command Code
		x = 1 for CH1 Prime Mode, x = 2 for Latch to CH2 Mode, x = 3 for Minimum Auto Switching Mode.
		The unit will append the '>' character if the command is successfully processed.

M&C Status Request/Inquiries Continued on page 10...

1.5 M&C Queries (continued)

Table 2.1 Model 1582-125L - M&C Status Request/Inquiries

(Continued from page 9)

Table 2.1: Model 1582-125L M&C Status Request/Inquires		
Command Function	Syntax	Command Description
Get RS485 Address	{aaSX}	Returns; {aaSXxx}
		where:
		aa = unit address, range = 00 to 31, only used if interface is RS485, otherwise omit
		X = Command Code
		xx = unit's RS485 address
		The unit will append the '>' character if the command is successfully processed.
Get Ch1 Alarm Polarity	{aaSK}	Returns; {aaSKx}
		where:
		aa = unit address, range = 00 to 31, only used if interface is RS485, otherwise omit
		K = Command Code
		x = Alarm input polarity, 0 if logic low = alarm, 1 if logic high = alarm
		The unit will append the '>' character if the command is successfully processed.
Get Ch2 Alarm Polarity	{aaSL}	Returns; {aaSLx}
		where:
		aa = unit address, range = 00 to 31, only used if interface is RS485, otherwise omit
		L = Command Code
		x = Alarm input polarity, 0 if logic low = alarm, 1 if logic high = alarm
		The unit will append the '>' character if the command is successfully processed.

2.0 Installation

2.1 Mechanical

The 1582-125L consists of one RF./Controller PCB and one IF piggyback PCB housed in a 1 RU (1 3/4 inch high) by 12 inch deep chassis. Redundant switching power supplies provide power for the assembly. The 1582-125L can be secured to a rack using the 4 holes on the front panel.

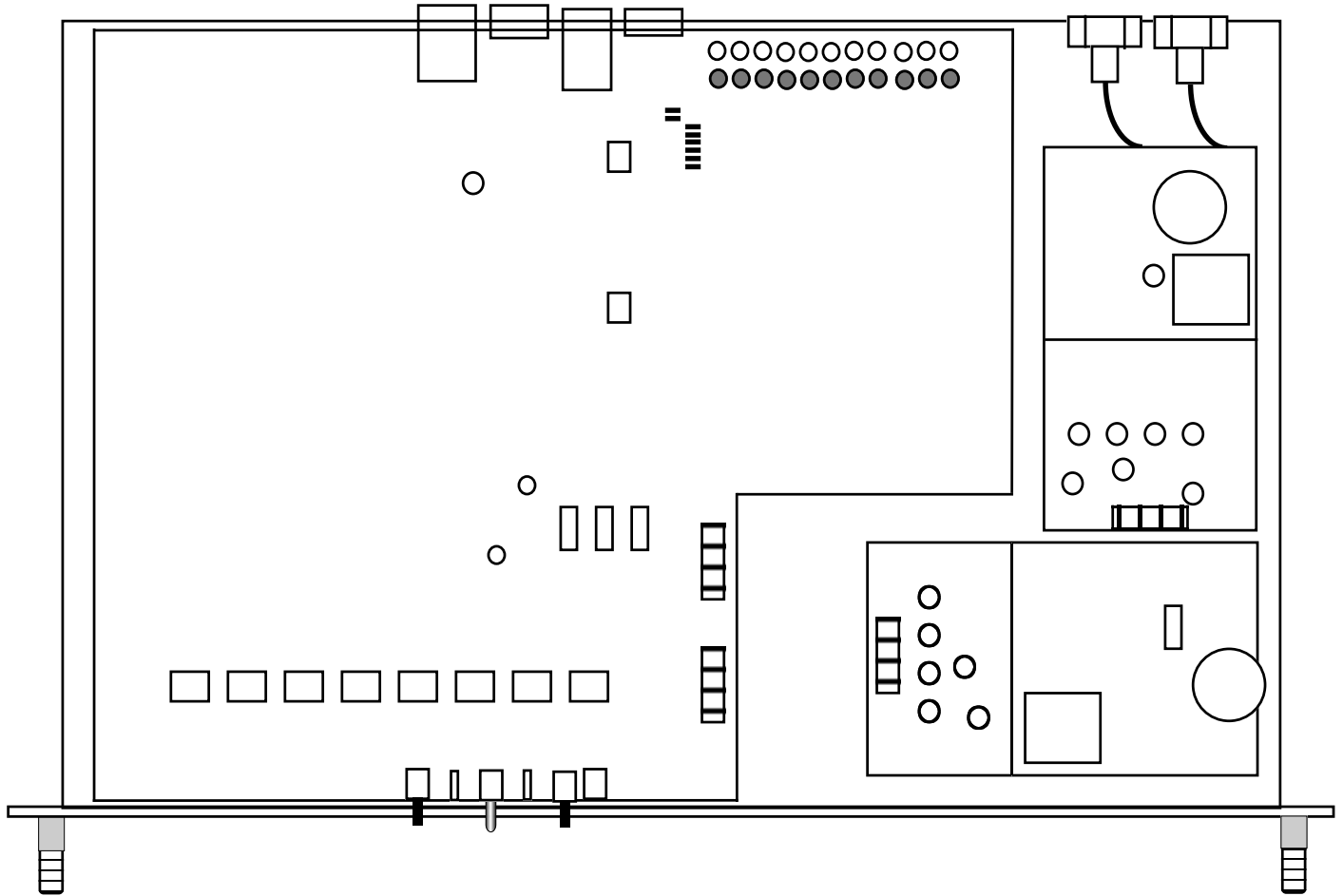

FIGURE 2.1 1582-125L RF Switch Assembly

2.2 Input and Output Signals

Figure 2.2 shows the input and output connectors on the rear panel.

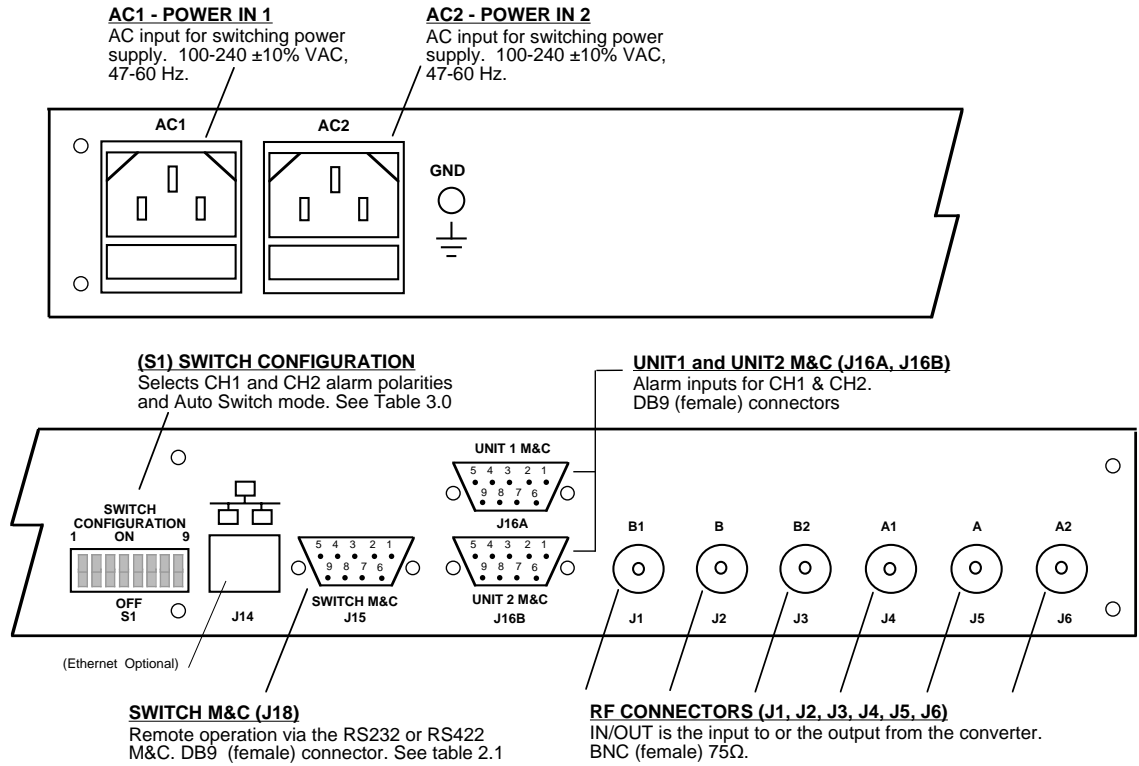

FIGURE 2.2 1582-125L Switch Rear Panel Inputs/Outputs

2.3 Controls and Indicators

Figure 2.3 shows the front panel controls and indicators.

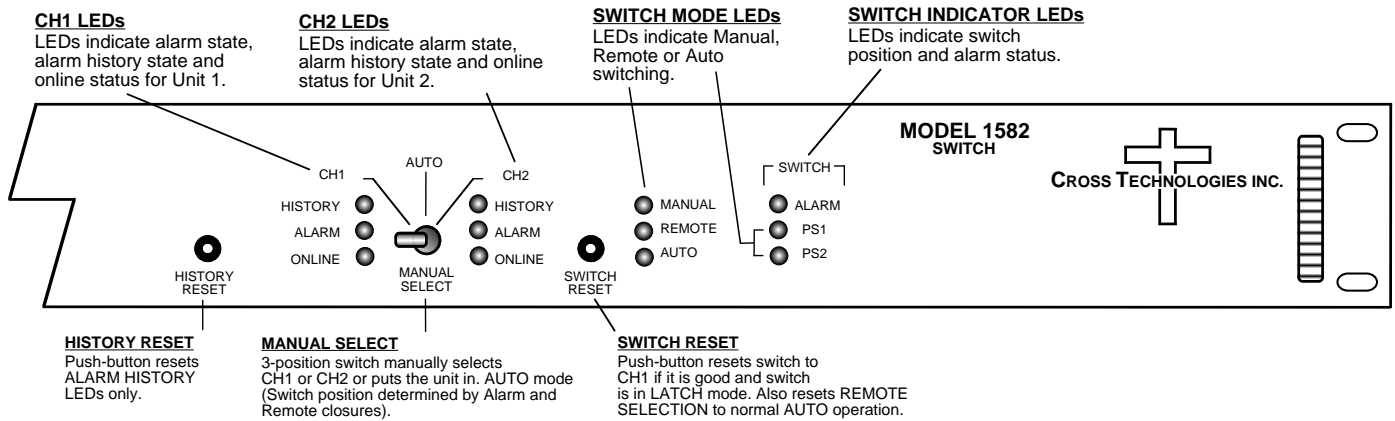

FIGURE 2.3 1582-125L Switch, Front Panel Controls and Indicators

2.4 Operation

1. Set the on board controls as desired (Tables 2.0, 2.1, Figure 2.3).
2. Install the 1582-125L in the equipment rack.
3. Connect RF to the BNC connectors (J1, J2, J3, J4, J5, J6).
4. Connect to signals on the MONITORS AND CONTROLS (DB9 connectors), J16A & J16B, as desired (see Figure 2.2, Table 2.1).
5. Connect power via two power cords to AC1 and AC2.
6. Manually switch between channels 1 and 2 and be sure switching occurs.
7. Switch to AUTO. Alarm channel 1 and note that automatic switching occurs. Remove alarm to CHI and note that the output switches as desired. Push RESET if in LATCH mode. Repeat for CHI.
8. Check that CHI and CHI are selected when in AUTO and momentary ground is applied to J7 pins 1 and 2. Momentarily ground Remote Reset pin 4 on J7 if in LATCH mode to return to AUTO operation.

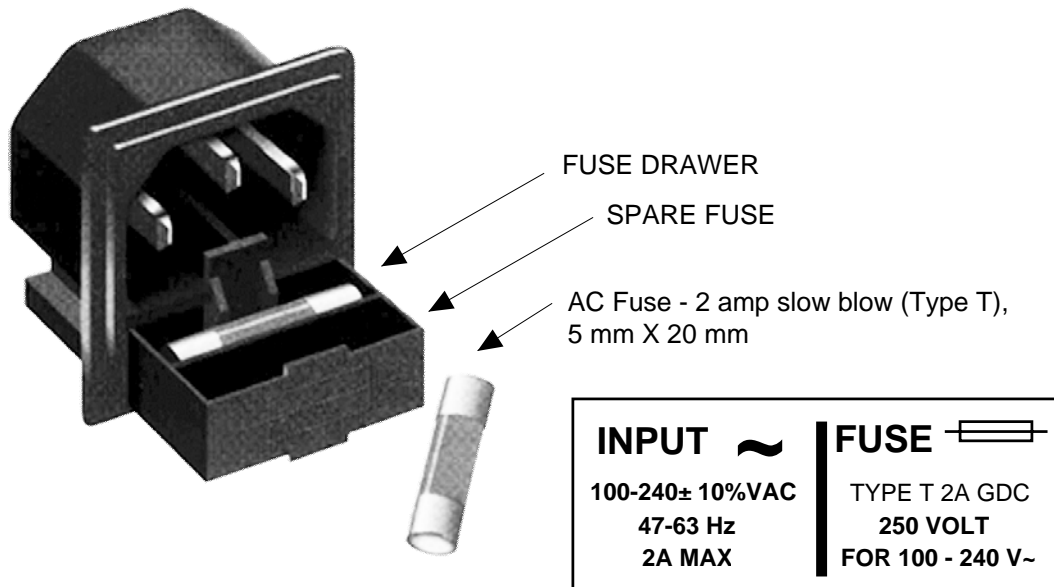

FIGURE 2.4 Fuse and Spare Fuse Locations

2.5 Auto Switching Description

Automatic control determines switch routing by monitoring alarm inputs on two channels (CH1, CH2) and selecting the initial source. Local and remote control of RF sources is also provided. Latching relays allow the switch to remain in its "current" state independent of power loss. The 1582-125L detects an external alarm condition on CH1 and CH2 by either a contact closure to ground or an open (selectable). Switching logic can be selected as follows:

- 1) CH1 Prime Mode** - Switches from CH1 to CH2 only if CH1 alarms and CH2 is good
Switches back to CH1 when it is no longer in alarm or when both CH1 and CH2 are in alarm
- 2) Latch to CH2 Mode** - Switches to CH2 if CH1 alarms and CH2 is good. Latches to CH2.
Push Manual Reset or ground Remote Reset pin to return to CH1 if it has no alarm or both CH1 and CH2 are in alarm.
- 3) Minimum AUTO switching, Initial Channel Select (ICS) Mode** - Switch stays on channel last selected by Manual or Remote selection after return to AUTO. AUTO switching occurs only if current channel alarms and the other channel is clear.

Switching is accomplished using latching relays so if power is removed from the 1582-125L, CH1 and CH2 RF will continue to go to the output selected prior to power loss and will remain there when power is applied assuming no change in alarm status from when power was lost. The channels can be manually switched by the front panel Manual Select switch. If operating in the ICS mode, the last channel manually selected (CH1 or CH2) will be the initial channel when returning the Manual Select switch to AUTO. External REMOTE contact closures can force selection of CH1 or CH2 when the Manual Select switch is in the AUTO position independent of the alarm conditions of CH1 or CH2. Front panel LEDs indicate alarms, alarm history (prior occurrence of alarms which have now cleared), switch conditions for CH1 and CH2, REMOTE or MANUAL operation and presence of power.

RF connectors are 75 Ω BNC, female (or see other options) and IF-L connectors are 75 Ω BNC, female. Contact closure inputs are via barrier strip. Dual power supplies provide redundant power to the 1582-125L. The chassis is a 1 3/4" rack mount.

Table 3.0 Model 1582-125L Switch - Configuration DIP Switch

Table 3.0 Model 1582-125L Configuration DIP Switch								
Select Serial M&C Interface (SW1, SW2)	SW1	SW2	SW3	SW4	SW5	SW6	SW7	SW8
RS232	OFF	OFF	X	X	X	X	X	X
RS422	ON	OFF	X	X	X	X	X	X
RS485	OFF	ON	X	X	X	X	X	X
Ethernet (Optional)	ON	ON	X	X	X	X	X	X
Select Auto Switching Mode (Switch A if Dual) (SW3, SW4)	SW1	SW2	SW3	SW4	SW5	SW6	SW7	SW8
CH1 Prime	X	X	ON	OFF	X	X	X	X
Latch to CH2	X	X	OFF	ON	X	X	X	X
Minimum Auto Switching	X	X	OFF	OFF	X	X	X	X
Select Alarm Input Polarity (Switch A if Dual) (SW5)	SW1	SW2	SW3	SW4	SW5	SW6	SW7	SW8
Normally Closed (Open = Alarm) (Logic High = Alarm)	X	X	X	X	OFF	X	X	X
Normally Open (Closed = Alarm) (Logic Low = Alarm)	X	X	X	X	ON	X	X	X
Select Auto Switching Mode (Switch B if Dual) (SW6, SW7)	SW1	SW2	SW3	SW4	SW5	SW6	SW7	SW8
CH1 Prime	X	X	X	X	X	ON	OFF	X
Latch to CH2	X	X	X	X	X	OFF	ON	X
Minimum Auto Switching	X	X	X	X	X	OFF	OFF	X
Select Alarm Input Polarity (Switch B if Dual) (SW8)	SW1	SW2	SW3	SW4	SW5	SW6	SW7	SW8
Normally Closed (Open = Alarm)	X	X	X	X	X	X	X	OFF
Normally Open (Closed = Alarm)	X	X	X	X	X	X	X	ON

3.0 Environmental Use Information

- A. **Rack-Mounting** - To mount this equipment in a rack, please refer to the installation instructions located in the user manual furnished by the manufacturer of your equipment rack.
- B. **Mechanical Loading** - Mounting of equipment in a rack should be such that a hazardous condition does not exist due to uneven weight distribution.
- C. **Elevated Operating Ambient Temperature** - If installed in a closed or multi-unit rack assembly, the operating ambient temperature of the rack may be greater than room ambient temperature. Therefore, consideration should be given to Tmra.
- D. **Reduced Air Flow** - Installation of the equipment in a rack should be such that the amount of air flow required for safe operation of the equipment is not compromised. Additional space between units may be required.
- E. **Circuit Overloading** - Consideration should be given to the connection of the equipment to the supply circuit and the effect that overloading of circuits could have on over current protection and supply wiring. Appropriate consideration of equipment name plate rating should be used, when addressing this concern.
- F. **Reliable Earthing** - Reliable earthing of rack-mounted equipment should be maintained. Particular attention should be given to supply connections other than direct connection to the Branch (use of power strips).
- G. **Top Cover** - There are no serviceable parts inside the product so, the Top Cover should not be removed. If the Top Cover is removed the ground strap and associated screw **MUST BE REINSTALLED** prior to Top Cover screw replacement. **FAILURE TO DO** this may cause **INGRESS** and/or **EGRESS** emission problems.



6170 Shiloh Road
Alphabet, Georgia 30005

(770) 886-8005
FAX (770) 886-7964
Toll Free 888-900-5588

WEB: www.crosstechnologies.com
E-MAIL: info@crosstechnologies.com

Printed in USA