

3116-79-3840 Block Downconverter, 7.9 - 8.4 GHz to 3.59 - 4.09 GHz

The 3116-79-3840 Downconverter converts 7.9 - 8.4 GHz to 3.59 - 4.09 GHz (non-inverted) with **9.36 and 5.05 GHz** local oscillators. The gain is +35 dB maximum and is adjustable in **0.5 ±0.5 dB** steps. Front panel LEDs provide indication of Remote operation, PLL Alarm and DC Power. Gain and internal/external/Auto reference frequency selection are controlled by front panel switches or remote selection (via RS-232C/485, standard; Ethernet Optional) and are viewable on the LCD Display. Connectors are N-Type female for the RF In and RF Out and BNC female for the external reference input and reference output. In AUTO, the 10 MHz reference stays in external if the external level is **+3 dBm, ±3 dB**. The 3116 is powered by a 100-240 ±10% VAC power supply, and housed in a 1 3/4" X 19" X 14" rack mount chassis.

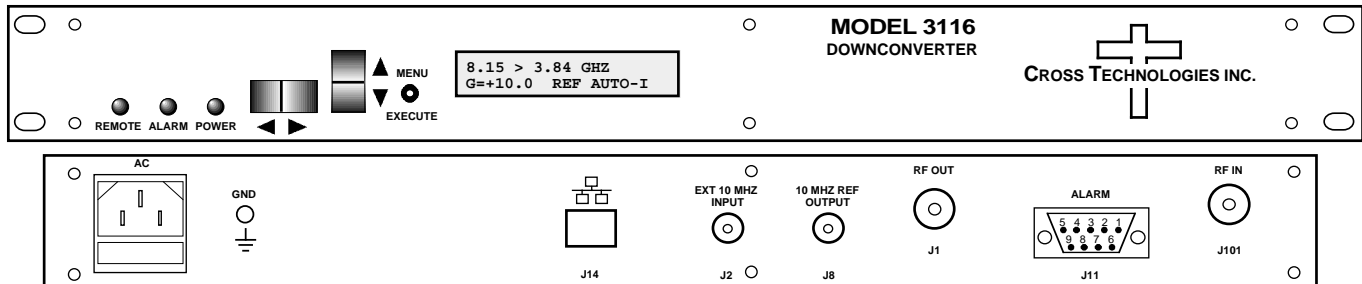

EQUIPMENT SPECIFICATIONS*

Input Characteristics (RF)

Impedance/Return Loss	50Ω/14 dB
Frequency	7.9 to 8.4 GHz
Noise Figure, Max.	15 dB max gain
Input Level range	-55 to -35 dBm
Input 1 dB compression	-25 dBm

Output Characteristics

Impedance/Return Loss	50Ω /14 dB
Frequency	3.59 to 4.09 GHz
Output Level Range	-20 to 0 dBm
Output 1 dB compression	+10 dBm at max. gain

Channel Characteristics

Gain, max; adjustment	+35 dB ±2 dB, max. gain; 30 dB adjustment in 0.5± 0.5 dB Steps
Image Rejection	> 60 dB, min
Spurious, In Band	-55 dBC in band, 0 dBm out; (3.59-4.09 GHz Out)
Spurious, Out of Band	<-50 dBm (2.5-3.59 GHz and 4.09-5.1 GHz Out)
Intermodulation	<-55 dBC for two carriers each at -10 dBm out
Frequency Response	±1.0 dB, 3.59 -4.09 GHz out; ± 0.5 dB, 40 MHz BW
Frequency Sense	Non-inverting

LO Characteristics

LO Frequencies	9.36 and 5.05 GHz
Frequency Accuracy	± 0.01 ppm max over temp internal ref.; ext. ref. input
10 MHz In/Out Level	3 dBm, ± 3 dB, w/ Auto-detect

Phase Noise @ F (Hz) >	10	100	1K	10K	100K	1M
Standard dBC/Hz	-55	-70	-80	-80	-95	-110

Controls, Indicators

Gain; Ext Ref Selection	Direct readout LCD; pushbutton switches or remote
Pwr; Alarm; Rem; Mute	Green LED; Red LED; Yellow LED; Yellow LED
Remote	RS232C/RS485/422, 9600 baud (Ethernet Optional)

Other

RF In Connector	N-Type (female), 50Ω
RF Out Connector	N-Type(female), 50Ω
10 MHz Connectors	BNC (female), 75Ω, works with 50 or 75 ohms
Alarm/Remote Conn.	DB9 - NO or NC contact closure on Alarm
Size	19 inch standard chassis 1.75" high X 14.0" deep
Power	100-240 ± 10% VAC, 47 - 63 Hz, 30 watts max.

Front and Rear Panel

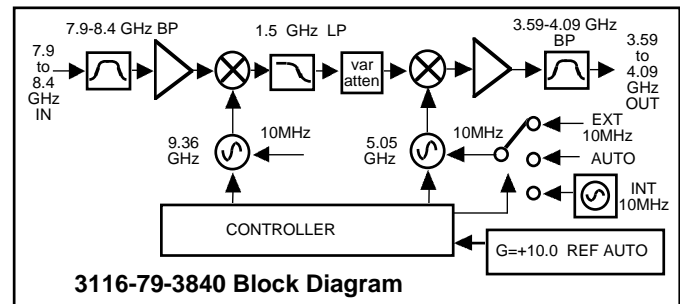

Available Options

W31 0 to +50 degrees C operation

Remote M&C Ethernet Options

- W8 - Ethernet w/web browser Interface
- W18 - Ethernet w/SNMP (and MIB) Interface
- W28 - Ethernet w/direct TCP/IP Interface

Connector Options

- N - 50Ω N-type (RF), 75Ω BNC (L-BAND)
- NF - 50Ω N-type (RF), 75Ω F-type (L-BAND)
- NN - 50Ω N-type (RF), 50Ω N-type (L-BAND)
- S7 - 50Ω SMA (RF), 75Ω BNC (L-BAND)
- SF - 50Ω SMA (RF), 75Ω F-type (L-BAND)
- SN - 50Ω SMA (RF), 50Ω N-type (L-BAND)
- SS - 50Ω SMA (RF), 50Ω SMA (L-BAND)

Contact Cross for other options

*10°C to 40°C; Specifications subject to change without notice