

3116-7786-1200 Block Downconverter, 7.75 - 8.65 GHz to 1200 ± 150 MHz

The 3116-7786-1200 Downconverter converts 7.75 - 8.65 GHz ($F_c = 7.9 - 8.5$ GHz) to 1200 ± 150 MHz (non-inverted) in 1 MHz steps (100 kHz, 125 kHz steps optional) with a 6.70 - 7.30 GHz local oscillator. The gain is +35 dB maximum with a 30 dB adjustment in 0.5 ± 0.5 dB steps. Front panel LEDs provide indication of Remote operation, PLL Alarm and DC Power. Frequency and internal/external/Auto reference mode selection are controlled by front panel switches or remote selection (via RS-232C/485, standard; Ethernet Optional) and are viewable on the LCD Display. Connectors are Type N female for the RF and BNC female for the L-Band and external reference input and reference output. In AUTO, the 10 MHz reference stays in external if the external level is +3 dBm, ±3 dB. The 3116 is powered by a 100-240 ± 10% VAC power supply, and housed in a 1 3/4" X 19" X 14" rack mount chassis.

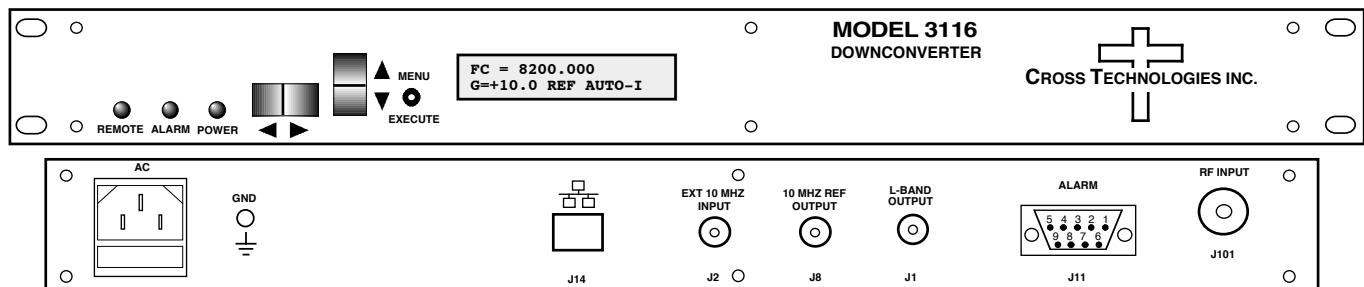

Front and Rear Panel (Shown with optional Ethernet)

EQUIPMENT SPECIFICATIONS*

Input Characteristics (RF)

Impedance/Return Loss	50Ω/14 dB
Frequency	7.75 to 8.65 GHz ($F_c = 7.9 - 8.5$ GHz)
Noise Figure, Max.	12 dB, max. gain
Input Level range	-55 to -35 dBm
Input 1 dB compression	-25 dBm

Output Characteristics (L-Band)

Impedance/Return Loss	50Ω /14 dB
Frequency	1200 ± 150 MHz
Output Level Range	-20 to 0 dBm
Output 1 dB compression	+10 dBm at max. gain

Channel Characteristics

Gain at F_c , Max.; adj.	+35 dB ± 2 dB, max. gain; 30 dB adjustment in 0.5± 0.5 dB Steps ($F_c = 7.9 - 8.5$ GHz)
Image Rejection	> 60 dB, min
Spurious, In Band	SIGNAL RELATED <-45 dBC, 0 dBm out; SIGNAL INDEPENDENT, <-55 dBm (1200 ±150 MHz Out)
Spurious, Out of Band	<-50 dBm (0.3-1.04 and 1.36-2.0 GHz Out)
Intermodulation	<-20 dBC for two carriers at 4 MHz spacing, each at -10 dBm out, at Gmax.
Frequency Response	±2.0 dB over the band, ± 1.0 dB 1200 ± 150 MHz out;
Frequency Sense	Non-inverting

LO Characteristics

LO Frequency	6.70 - 7.30 GHz, 1 MHz steps; 100 kHz, 125 kHz steps opt.
Frequency Accuracy	± 0.01 ppm max over temp internal reference; ext. ref. input
10 MHz In/Out Level	3 dBm, ± 3 dB, w/ Auto-detect

Phase Noise @ F (Hz) >	10	100	1K	10K	100K	1M
Standard dBC/Hz	-55	-75	-80	-80	-100	-120

Controls, Indicators

Freq.; Ext Ref Selection	Direct readout LCD; pushbutton switches or remote
Pwr; Alarm; Rem; Mute	Green LED; Red LED; Yellow LED; Yellow LED
Remote	RS232C/RS485/422, 9600 baud (Ethernet Optional)

Other

RF Connector	N-Type (female), 50Ω
L-Band Connector	BNC (female), 50Ω
10 MHz Connectors	BNC (female), 75Ω, works with 50 or 75 ohms
Alarm/Remote Conn.	DB9 - NO or NC contact closure on Alarm
Size	19 inch standard chassis 1.75" high X 14.0" deep
Power	100-240 ± 10% VAC, 47 - 63 Hz, 30 watts max.

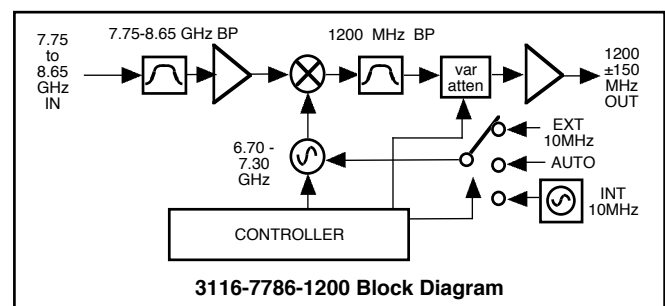

3116-7786-1200 Block Diagram

Available Options

- X - 125 kHz frequency step
- X1 - 100 kHz frequency step

Remote M&C Ethernet Options

- W8 - Ethernet w/web browser Interface
- W18 - Ethernet w/SNMP (and MIB) Interface
- W28 - Ethernet w/direct TCP/IP Interface
- W828 - W8 +W18 +W28

Connector Options

- N - 50Ω N-type (RF), 75Ω BNC (L-BAND)
- NS - 50Ω N-type (RF), 50Ω SMA (L-BAND)
- S7 - 50Ω SMA (RF), 75Ω BNC (L-BAND)
- SS - 50Ω SMA (RF), 50Ω SMA (L-BAND)

Contact Cross for other Options

*10°C to 40°C; Specifications subject to change without notice