

3116-2629# Block Downconverter, 2.60 - 2.90 GHz to 0.85 - 1.15 GHz

The 3116-2629# Downconverter converts 2.60 - 2.90 GHz to 0.85 - 1.15 GHz (inverted) with a 3.75 GHz local oscillator. The gain is +35 dB maximum and is adjustable in 0.5 ± 0.5 dB steps. Front panel LEDs provide indication of Remote operation, PLL Alarm and DC Power. Gain and internal/external/Auto reference frequency selection are controlled by front panel switches or remote selection (via RS-232C/485, standard; Ethernet Optional) and are viewable on the LCD Display. Connectors are Type N female for the RF and BNC female for the L-Band and external reference input and reference output. In AUTO, the 10 MHz reference stays in external if the external level is **+3 dBm, ± 3 dB**. The 3116 is powered by a 100-240 $\pm 10\%$ VAC power supply, and housed in a 1 3/4" X 19" X 14" rack mount chassis.

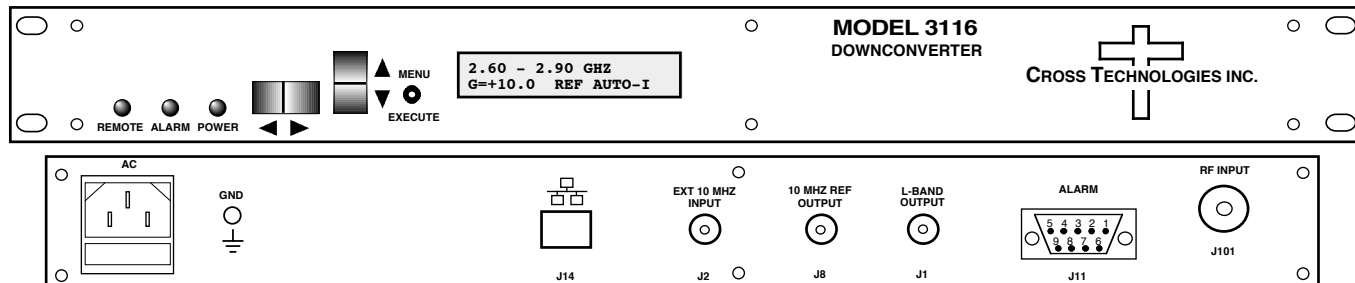

EQUIPMENT SPECIFICATIONS*

Input Characteristics (RF)

Impedance/Return Loss	50 Ω /14 dB
Frequency	2.60 to 2.90 GHz
Noise Figure, Max.	12 dB max gain
Input Level range	-55 to -35 dBm
Input 1 dB compression	-25 dBm

Output Characteristics (L-Band)

Impedance/Return Loss	50 Ω / 14 dB
Frequency	0.85 to 1.15 GHz
Output Level Range	-20 to 0 dBm
Output 1 dB compression	+10 dBm at max. gain

Channel Characteristics

Gain, max; adjustment	+35 dB ± 2 dB, max. gain at Fc; 30 dB adjustment in 0.5 ± 0.5 dB Steps
Image Rejection	> 60 dB, min
Spurious, In Band	<-55 dBc in band, 0 dBm out; (0.85-1.15 GHz Out) ; max. gain
Spurious, Out of Band	<-50 dBm (0.5-0.84 GHz and 1.16-2.5 GHz Out) ; max. gain
Intermodulation	<-55 dBc for two carriers spaced at Fc ± 2 MHz, each at -10 dBm out; max. gain
Frequency Response	± 1.5 dB, 0.85 - 1.15 GHz out; ± 0.5 dB, 40 MHz BW
Frequency Sense	Inverting

LO Characteristics

LO Frequency	3.75 GHz
Frequency Accuracy	± 0.01 ppm max over temp internal reference; ext. ref. input
10 MHz In/Out Level	3 dBm, ± 3 dB, w/ Auto-detect

Phase Noise @ F (Hz) >	100	1K	10K	100K	1M
Standard dBc/Hz	-60	-70	-80	-90	-110

Controls, Indicators

Gain; Ext Ref Selection	Direct readout LCD; pushbutton switches or remote
Pwr; Alarm; Rem; Mute	Green LED; Red LED; Yellow LED; Yellow LED
Remote	RS232C/RS485/422, 9600 baud (Ethernet Optional)

Other

RF Connector	Type N (female), 50 Ω
L-Band Connector	BNC (female), 50 Ω
10 MHz Connectors	BNC (female), 75Ω, works with 50 or 75 ohms
Alarm/Remote Conn.	DB9 - NO or NC contact closure on Alarm
Size	19 inch standard chassis 1.75" high X 14.0" deep
Power	100-240 $\pm 10\%$ VAC, 47 - 63 Hz, 30 watts max.

Front and Rear Panel (Shown with optional Ethernet)

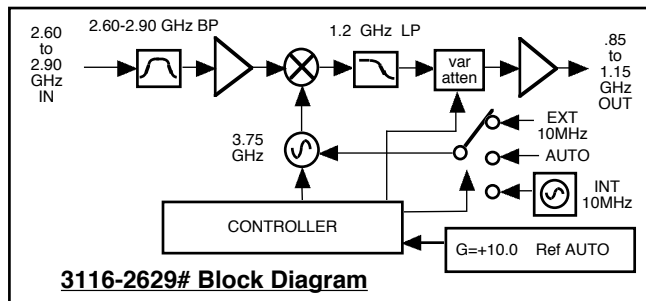

Available Options

W31 0 to +50 degrees C operation

Remote M&C Ethernet Options

- W8 - Ethernet w/web browser Interface
- W18 - Ethernet w/SNMP (and MIB) Interface
- W28 - Ethernet w/direct TCP/IP Interface
- W828 - W8 +W18 +W28**

Connector Options

- N - 50 Ω N-type (RF), 75 Ω BNC (L-BAND)
- NF - 50 Ω N-type (RF), 75 Ω F-type (L-BAND)
- NN - 50 Ω N-type (RF), 50 Ω N-type (L-BAND)
- S7 - 50 Ω SMA (RF), 75 Ω BNC (L-BAND)
- SF - 50 Ω SMA (RF), 75 Ω F-type (L-BAND)
- SN - 50 Ω SMA (RF), 50 Ω N-type (L-BAND)
- SS - 50 Ω SMA (RF), 50 Ω SMA (L-BAND)

Contact Cross for other options

*10°C to 40°C; Specifications subject to change without notice