

3115-277#-1200 Agile Block Upconverter, 1200 ± 400 MHz to 25.5 - 27.7 GHz

The 3115-277#-1200 Agile Block Upconverter converts 1200 ± 400 MHz to 25.5 to 27.7 GHz in 5 MHz steps. This unit converts 1200 MHz to 5.9 GHz and 5.9 GHz to 25.5 - 27.7 GHz. Synthesized local oscillators (LO) provide frequency selection. Multi-function switches select the RF frequency, gain, and other parameters. Front panel LEDs provide indication of DC power (green), PLL alarm (red), and remote operation (yellow). Variable attenuators for the 1200 MHz input provide a gain range of 0 to +20 dB as adjusted by the front panel multi-function switches. Remote operation allows selection of frequency and gain. Parameter selection and frequency and gain settings appear on the LCD display. Connectors are BNC (female) for 1200 MHz and external 10MHz reference input and output, and 2.92 mm (female) for the RF output. The unit is powered by a 100-240 ±10% VAC power supply, and housed in a 1 3/4" X 19" X 14" rack mount chassis.

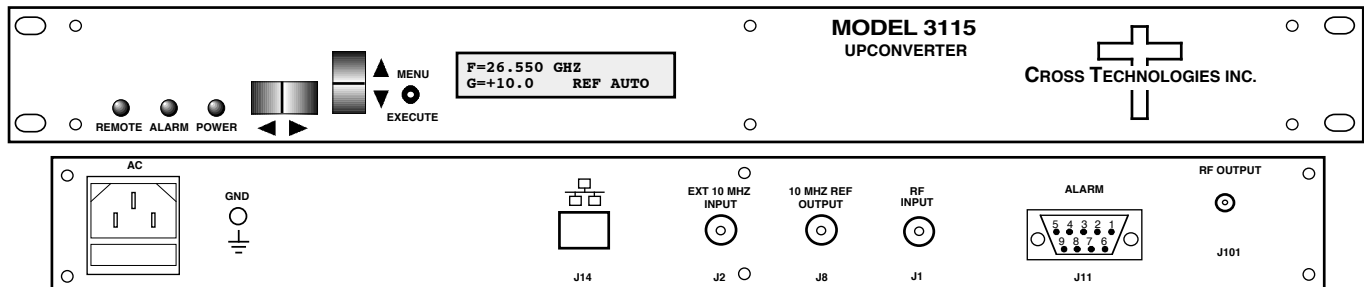

Front and Rear Panels (shown with optional Ethernet)

EQUIPMENT SPECIFICATIONS*

Input Characteristics

Impedance	75 Ω
Return Loss	14 dB
Frequency	1200 ± 400 MHz
Input Level	-30 to -10 dBm

Output Characteristics

Impedance	50 Ω
Return Loss	14dB
Frequency	25.5 to 27.7 GHz
Output level	-20 to -5 dBm
Output 1 dB compression	+5 dBm, at max. gain

Channel Characteristics

Gain Max. /range	+20.0 ± 3 dB; adjustable from 0 to +20.0 dB, 0.5 ±0.5 dB steps
Spurious, Inband	< -50 dBC, at max. gain
Spurious, Out of band	< -50 dBm, 24.0 - 25.4 and 27.8 - 29 GHz, at max. gain
Intermod	< -50 dBC for two carriers spaced 4 Mhz apart each at -5 dBm out, at max. gain
Frequency Response	±3.0 dB, 25.5-27.7 GHz; ±1.5 dB, any 800 MHz band
Frequency Sense	Non-inverting

Synthesizer Characteristics

Frequency Accuracy	± 0.01 ppm max. over temp internal ref.; ext ref. input
Frequency Step	5 MHz minimum
External 10 MHz level	+3 dBm ± 3 dB, 50Ω

Phase Noise @ Freq	100 Hz	1kHz	10kHz	100kHz	1 MHz
dBC/Hz	60	70	80	90	100

Controls, Indicators

Freq/Gain Selection	Direct readout LCD; manual or remote selection
Power; Alarm; Remote	Green LED; Red LED; Yellow LED
Remote	RS232C/RS485/422, 9600 baud (Ethernet/opt -W8,18, 28)

Other

RF Connector	2.92 mm (female)
1200 MHz, Connector	BNC (female), 75 Ω
10 MHz Connectors	BNC (female), 75Ω, works with 50 or 75 ohms
Alarm/Remote Connector	DB9 (female) - NO or NC contact closure on Alarm
Size	19 inch, 1RU standard chassis 1.75" high X 14.0" deep
Power	100-240 ±10% VAC, 47-63 Hz, 30 watts max.

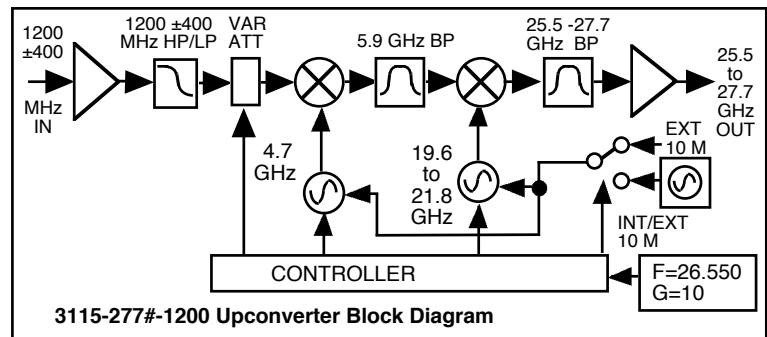

Available Options

- W8 - Ethernet; w/Web Browser (WB)
- W18 - Ethernet; w/WB & SNMP
- W28 - Ethernet; w/TCP/IP, Telnet

Connectors/Impedance

- S2 - 2.92mm (RF), 50Ω BNC (IF)
- SS2- 2.92mm (RF), SMA (IF)
- Contact Cross for other options

*10°C to 40°C; Specifications subject to change without notice