



DATA SHEET

12/14/11

REV. B

2582-282 Backup Switch, 1 for 8

The 2582-282 1 for 8 Switch with Backup Controller provides Auto or Manual backup protection for up to 8 converters by relay switching IF and RF signals from one backup unit to any of 8 on-line units. The controller in the 2582-282 monitors alarms and settings of the on-line units and sets the backup unit to the parameters of the unit being backed up prior to backing it up. The 2582-282 works with standard Cross Up or Downconverters by polling their monitor and control ports on a periodic basis. A defective unit's inputs and outputs are switched from the failed unit to the backup when a failure occurs either automatically or manually. "On-line", "Off-line" and "not used" modes can be programmed for each converter. Alarms are contact closures to ground. Status of the 2582-282 is reported via a serial data stream (Ethernet, Optional) and a contact closure to ground on alarm.

All user settings of the switch are stored in nonvolatile ROM and on power up the 2582-282 polls all units. Manual Select is controlled by the multi-function switches on the front panel. LEDs indicate alarm and switch conditions. The unit is powered by two 100-240 ±10% VAC redundant power supplies, and housed in a 2RU chassis.

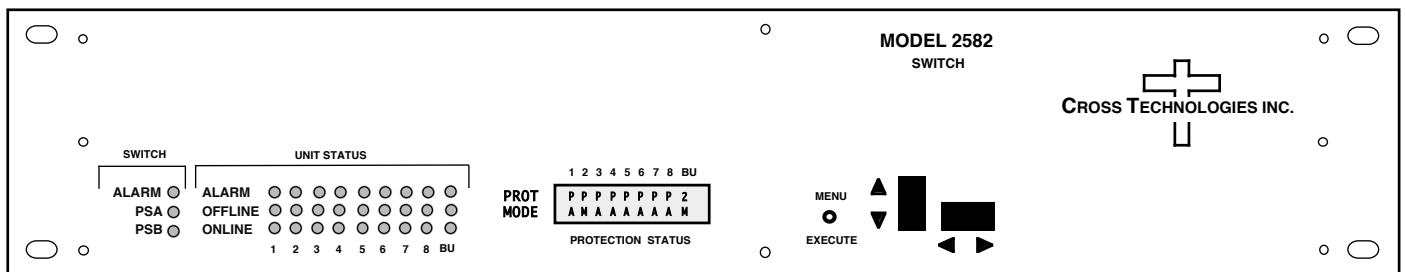

Front Panel

EQUIPMENT SPECIFICATIONS*

IF/L-Band Switch Characteristics

Impedance/Return Loss 50 Ω / > 12 dB Return Loss
 Type Relay
 Isolation > 55 dB, DC to 1.5 GHz
 > 50 dB, to 2.2 GHz;
 Switch time ≤ 100 milliseconds
 Insertion Loss ≤ 1.5 dB, to 1.5 GHz;
 ≤ 2.0 dB, to 2.2 GHz
 Configuration 1 for 8, no termination

RF/L-Band Switch Characteristics

Impedance/Return Loss 50 Ω / > 12 dB Return Loss
 Type Relay
 Isolation > 55 dB, DC to 1.5 GHz
 > 50 dB, to 2.2 GHz;
 Switch time ≤ 100 milliseconds
 Insertion Loss ≤ 1.5 dB, to 1.5 GHz;
 ≤ 2.0 dB, to 2.2 GHz
 Configuration 1 for 8, no termination

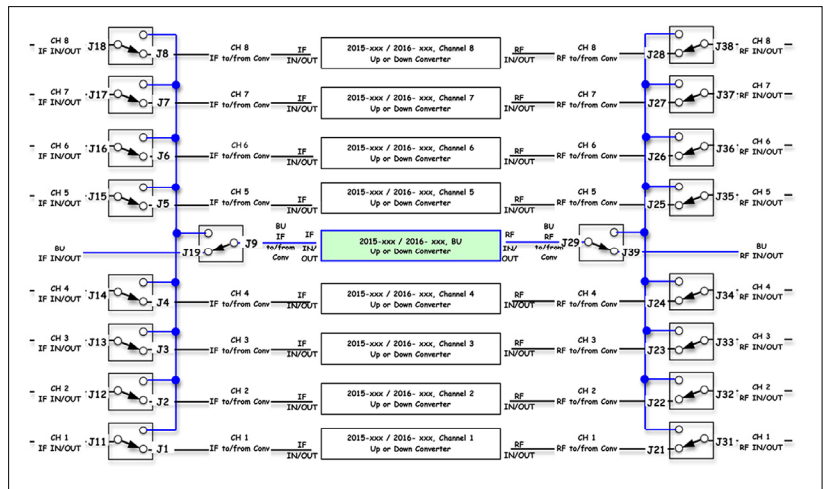

Block Diagram

Controls, Indicators

Manual Selection Push-button switches
 Remote Selection RS 232C (Optional RS 422/485 Option Q; Ethernet Option W8)
 Power Green LEDs
 Alarms Red LEDs
 Online/Offline Green LEDs / Yellow LEDs

Other

RF Connectors SMA (female)
 IF/L-Band Connectors BNC (female)
 Alarm/Remote Conn's DB9 (female)
 Size 19 inch, 2RU Standard Chassis X 16.0" D
 Power 100-240 VAC, Redundant power supplies

*+10°C to +40°C; Specifications subject to change without notice