

2117-7173 Up/Downconverter, 7.17-7.255 GHz Up, 7.17-7.255 GHz Down

The 2117-7173 Up/Downconverter converts **2.025 - 2.11 GHz to 7.17 - 7.255 GHz** and **7.17-7.255 GHz to 2.025 - 2.11 GHz**, with **non-inverting spectrums**. Front panel LEDs provide indication of DC Power, External 10 MHz, and PLL Alarm. The gain is **+20 dB for the upconverter and -20 dB for the downconverter**. Connectors are **Type N female for the RF2 OUT and RF1 IN, BNC female for the RF2 IN and RF1 OUT** and external reference input and reference output. A three-way switch controls which 10 MHz reference is being used. In the AUTO position, the internal reference is used unless a +3 dBm ± 3 dB, 10MHz reference signal is connected to the external reference input. The 2117 is powered by a 100-240 ± 10% VAC power supply, and in a 1 3/4" X 19" X 16" rack mount chassis.

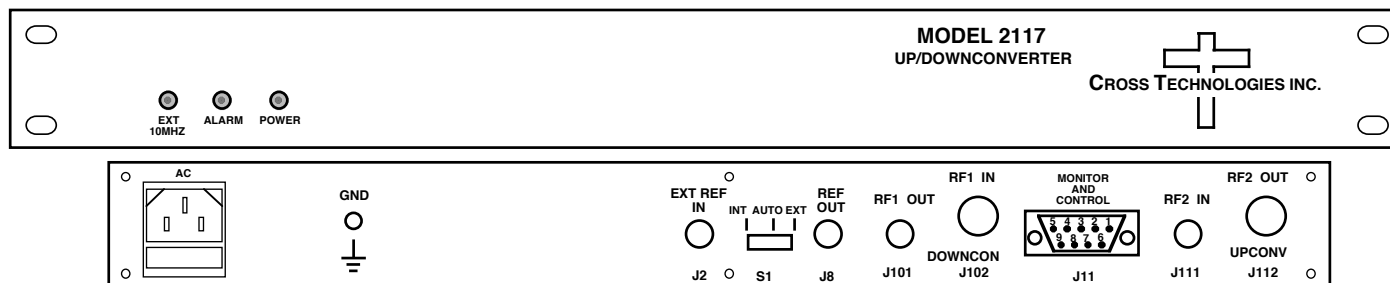

Front and Rear Panels

EQUIPMENT SPECIFICATIONS*		
Input Characteristics	UP	DOWN
Impedance/Return Loss	50Ω/14 dB	50Ω/14 dB
Frequency	2.025-2.11 GHz	7.17-7.255 GHz
Noise Figure, Max.	20 dB @ max gain	25 dB @ max gain
Input Level range	-40 to -20 dBm	-20 to 0 dBm
Output Characteristics		
Impedance/Return Loss	50 Ω /14 dB	50 Ω /14 dB
Frequency (GHz)	7.17-7.255 GHz	2.025-2.11 GHz
Output Level Range	-20 to 0 dBm	-40 to -20 dBm
1 dB comp, max gain	+10 dBm	-10 dBm
Mute @ 0 dBm out	>50 dB	N/A
Channel Characteristics		
Gain, max. at Fc, fixed	+20 ±2 dB	-20 ±2 dB
Image Rejection	>60 dBC	>60 dBC
Spurious, Inband, sig. rel.	<-50 dBC, 0dBm	<-50 dBC, -5dBm
Spurious, Inband, sig. ind.	<-50 dBC, Gmax	<-50 dBC, Gmax
Spurious, Out of band	<-50 dBm, Gmax	<-50 dBm, Gmax
2 tone 4MHz; Max -10 ea	<-50 dBC, Gmax	<-50 dBC, Gmax
Frequency Resp. band	±1.5 dB	±1.5 dB
Frequency Resp. 40 MHz	± 0.5 dB	± 0.5 dB
Frequency Sense	non-inverting	non-inverting

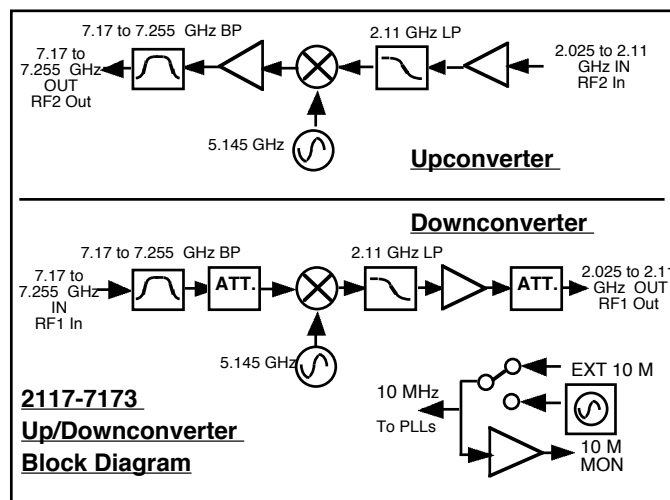

**2117-7173
Up/Downconverter
Block Diagram**

LO Characteristics

LO Frequency **Downconverter - 5.145 GHz; Upconverter - 5.145 GHz**
 Frequency Accuracy ± 0.01 ppm max over temp internal reference; ext. ref. input

Phase Noise @ F (Hz) >	100	1K	10K	100K	1M
dBC/Hz	-70	-80	-85	-100	-110

10 MHz level +3 dBm, ± 3 dB, 75 ohms, External In or Internal out

Controls, Indicators

INT/AUTO/EXT Switch Selects internal or external 10 MHz (rear panel DP3T switch)
 Ext 10 MHz Yellow LED, indicates external 10 MHz reference selected
 PLL Alarm Red LED, **External contact closure**
 Power Green LED

Other

RF1 In, RF2 Out N-type (female), 50Ω
RF1 Out, RF2 In BNC (female), 50Ω
 10 MHz connectors BNC (female), 75Ω connector; works with 50Ω or 75Ω
 Alarm Connector DB9 - NO or NC contact closure
 Size 19 inch standard chassis 1.75" high X 16" deep
 Power 100-240 ± 10% VAC, 47 - 63 Hz, 50 watts maximum

Available Options

P48 = 48V DC Power Supply
 R = Redundant AC Power Supply

Available Connector Options

NF = 50Ω N-type (RF), 75Ω F-type (L-Band)
 N = 50Ω N-type (RF), 75Ω BNC (L-Band)
 NN = 50Ω N-type (RF), 50Ω N-type (L-Band)
 SS = 50Ω SMA (RF), 50Ω SMA (L-Band)

*+10 to +40 degrees C; Specifications subject to change without notice