

2116-31T21 Block Translator, 30.0 - 31.0 GHz to 20.2 - 21.2 GHz

The 2116-31T21 Block Translator converts 30.0 - 31.0 GHz to 20.2 - 21.2 GHz with a local oscillator at 9.80 GHz. Front panel LEDs provide indication of DC Power, External 10 MHz, and PLL Alarm. The gain is -30 dB. Connectors are 2.92mm female for RF In, Super SMA female for RF Out and BNC female for the external reference input and reference output. A three-way switch controls which 10 MHz reference is being used. When in the AUTO position, the internal reference is used unless a +3 dBm ± 3 dB, 10MHz reference signal is connected to the external reference input. The 2116 is powered by a 100-240 ±10% VAC power supply, and mounted in a 1 3/4" X 19" X 14" rack mount chassis.

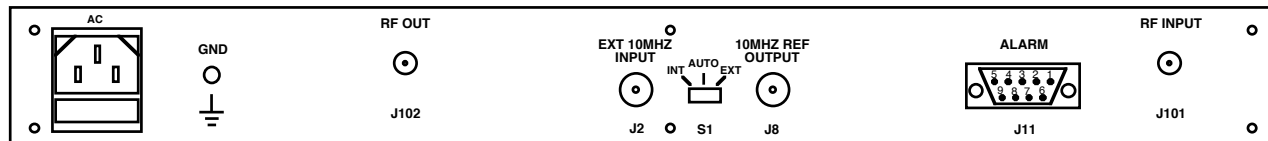

Front and Rear Panels

EQUIPMENT SPECIFICATIONS*

Input Characteristics

Impedance / Return Loss 50Ω / **14dB min.**
 Frequency 30.0 to 31.0 GHz
 Input Level range -30 to -10 dBm
 Input 1 dB compression **0 dBm**

Output Characteristics

Impedance/Return Loss 50Ω / **15 dB, typ., 14dB min.**
 Frequency 20.2 to 21.2 GHz
 Output Level Range -60 to -40 dBm
 Output 1 dB compression **-30 dBm**

Channel Characteristics

Gain -30 dB ±2 dB at Fc
 Input/Output Isolation >**40 dB**, min
 Intermodulation >50 dBC for two carriers **each at -15 dBm in**
 Spurious, Inband SIGNAL RELATED <-50 dBC, typ., **-40 dBC max**; SIGNAL INDEPENDENT <-80 dBm;
 Spurious, Out of band, 2XLO **<-45 dBm, at 19.6 GHz at the output**
 Frequency Response ±2.0 dB, over frequency band; ± 0.5 dB, 40 MHz BW
 Frequency Sense Non-inverting

LO Characteristics

LO Frequency 9.80 GHz
 Frequency Accuracy ± 0.01 ppm max over temp internal reference; ext. ref. input
 10 MHz In/Out Level +3 dBm ± 3 dB

Phase Noise @ F (Hz) >	100	1K	10K	100K	1M
dBC/Hz	-70	-80	-85	-95	-110

Controls, Indicators

Power Green LED
 PLL Alarm Red LED, External contact closure
 Ext 10 MHz Yellow LED, indicates external 10 MHz reference selected (rear panel DPDT switch)
 10 MHz Reference 3-way Switch (selects INTERNAL, EXTERNAL, or AUTO mode)

Other

RF In / RF Out Con. 2.92 mm / Super SMA
 10 MHz Connectors BNC (female), 50Ω/75Ω
 Alarm Connector DB9 - NO or NC contact closure on Alarm
 Size 19 inch standard chassis 1.75" high X 14" deep
 Power 100-240 ±10% VAC, 47 - 63 Hz, 45 watts max.

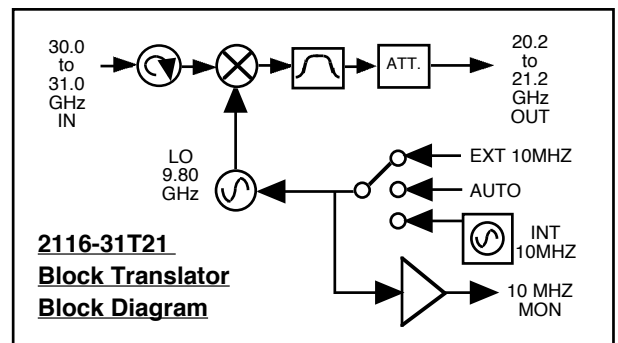

*10°C to 40°C; Specifications subject to change without notice