

2116-23#-1100 Block Downconverter, 2300 ± 200 MHz to 1100 ±200 MHz

The **2116-23#-1100** Block Downconverter converts **2300 ± 200 MHz** to **1100 ±200 MHz** (inverted) with a **3.40 GHz** local oscillator. Front panel LEDs provide indication of DC Power, External 10 MHz, and PLL Alarm. The gain is +35 dB. Connectors are Type N female for the RF and BNC female for the L-Band and external reference input and reference output. A three-way switch controls which 10 MHz reference is being used. In the INT position, the internal reference is used, in the EXT position, the external reference is used, and in the AUTO position, the internal reference is used unless a 3dBm ± 3dB, 10MHz signal is connected to the external reference input. The 2116-23#-1100 is powered by a 100-240 ±10% VAC power supply, and mounted in a 1 3/4" X 19" X 14" rack mount chassis.

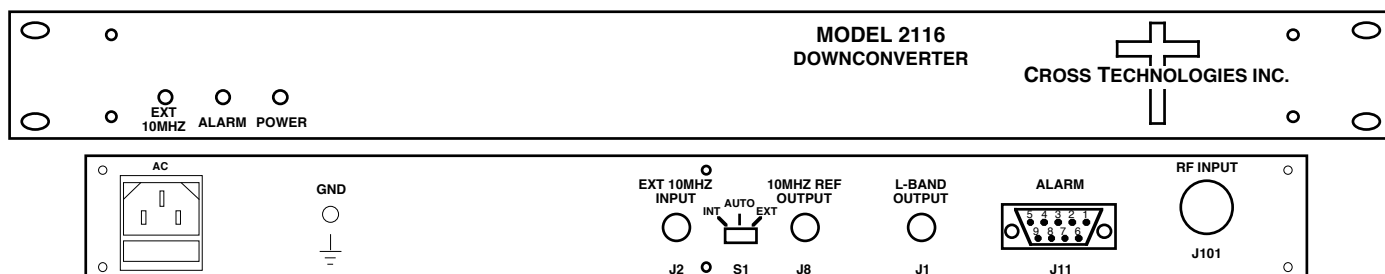

EQUIPMENT SPECIFICATIONS*

Input Characteristics (RF)

Impedance/Return Loss	50Ω/14 dB
Frequency	2300 ± 200 MHz
Noise Figure, Max.	15 dB max gain
Input Level range	-55 to -35 dBm
Input 1 dB compression	-25 dBm

Output Characteristics

Impedance/Return Loss	50Ω /14 dB
Frequency	1100 ±200 MHz
Output Level Range	-20 to 0 dBm
Output 1 dB compression	+10 dBm

Channel Characteristics

Gain @ Fc	+35 dB ±2 dB
Image Rejection	> 60 dB, min
Spurious, In Band	SIGNAL RELATED <-55 dBC, 0 dBm out; SIGNAL INDEPENDENT, <-60 dBm (1100 ±200 MHz Out)
Spurious, Out of Band	<-50 dBm (0.2-.89 and 1.31-2.0 GHz Out)
Intermodulation	<-55 dBC for two carriers at 4 MHz spacing , each at -10 dBm out
Frequency Response	±1.5 dB, 1100 ±200 MHz out ; ± 0.5 dB, 40 MHz BW; < -40 dB, 1100 ±350 MHz out
Frequency Sense	Inverting

LO Characteristics

LO Frequency	3.40 GHz
Frequency Accuracy	± 0.01 ppm max over temp internal reference; ext. ref. input
10 MHz In/Out Level	3 dBm, ± 3 dB

Phase Noise @ Freq	100 Hz	1kHz	10kHz	100kHz	1 MHz
dBC/Hz	-75	-85	-90	-100	-120

Controls, Indicators

Ext 10 MHz	Yellow LED, indicates external 10 MHz reference selected (rear panel DPDT switch)
Power	Green LED
PLL Alarm	Red LED, External contact closure

Other

RF, L-Band Connector	N-type (female), 50Ω, BNC (female), 50Ω
10 MHz Connectors	BNC (female), 50Ω/75Ω
Alarm Connector	DB9 - NO or NC contact closure on Alarm
Size	19 inch standard chassis 1.7" high X 14.0" deep
Power	100 - 240 ±10% VAC, 47 - 63 Hz, 25 watts max.

*10°C to 40°C; Specifications subject to change without notice

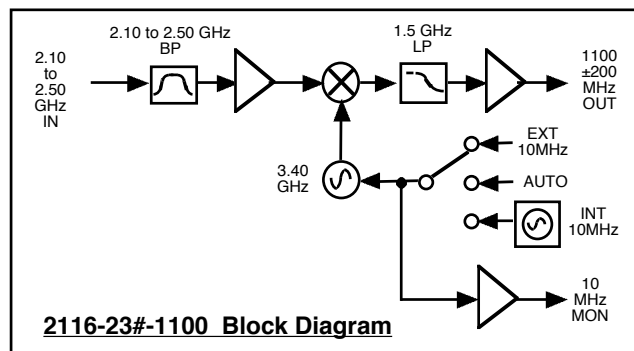

Available Connector Options-

N -	50Ω N-type (RF), 75Ω BNC (L-BAND)
NF -	50Ω N-type (RF), 75Ω F-type (L-BAND)
NN -	50Ω N-type (RF), 50Ω N-type (L-BAND)
S7 -	50Ω SMA (RF), 75Ω BNC (L-BAND)
SF -	50Ω SMA (RF), 75Ω F-type (L-BAND)
SN -	50Ω SMA (RF), 50Ω N-type (L-BAND)
SS -	50Ω SMA (RF), 50Ω SMA (L-BAND)