

2116-140 Block Downconverter, 14.0 - 14.5 GHz

The 2116-140 Block Downconverter converts 14.0 - 14.5 GHz to 0.95 - 1.45 GHz with a local oscillator at 13.05 GHz. Front panel LEDs provide indication of DC Power, External 10 MHz, and PLL Alarm. The gain is +35 dB. Connectors are SMA female for the RF and BNC female for the L-Band and external reference input and reference output. A three-way switch controls which 10 MHz reference is being used. In the INT position, the internal reference is used, in the EXT position, the external reference is used, and in the AUTO position, the internal reference is used unless a 3 dBm ± 3 dB, 10MHz reference signal is connected to the external reference input. The 2116 is powered by a 100-240 ±10% VAC power supply, and mounted in a 1 3/4" X 19" X 14" rack mount chassis.

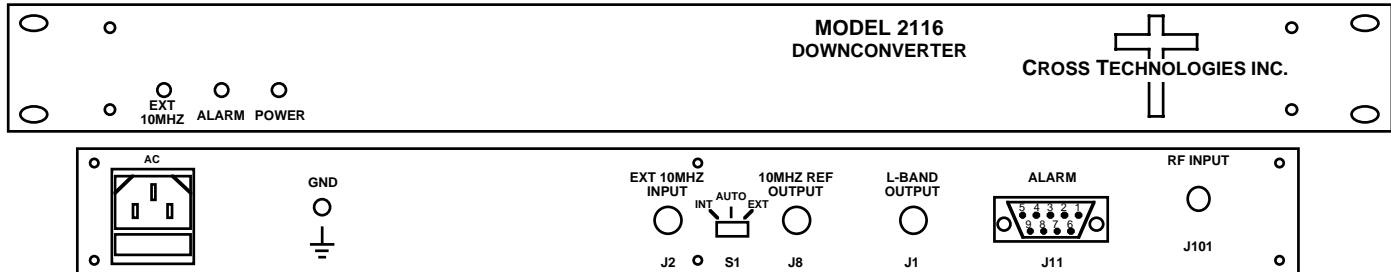

Front and Rear Panels

EQUIPMENT SPECIFICATIONS*

Input Characteristics

Impedance/Return Loss	50Ω/14 dB
Frequency	14.0 to 14.5 GHz
Noise Figure, Max.	12 dB max gain
Input Level range	-55 to -35 dBm
Input 1 dB compression	-25 dBm

Output Characteristics

Impedance/Return Loss	50Ω /14 dB
Frequency	0.95 to 1.45 GHz
Output Level Range	-20 to 0 dBm
Output 1 dB compression	+10 dBm

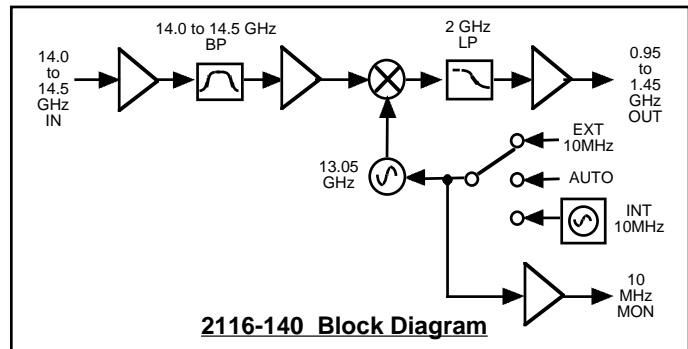

2116-140 Block Diagram

Channel Characteristics

Gain	+35 dB ±2 dB
Image Rejection	> 60 dB, min
Spurious, In Band	SIGNAL RELATED <-60 dBc in band, 0 dBm out; SIGNAL INDEPENDENT, <-60 dBm
Spurious, Out of Band	<-50 dBm
Intermodulation	<-55 dBc for two carriers each at -10 dBm out
Frequency Response	±1.5 dB, 0.95 - 1.7 GHz out; ± 0.5 dB, 40 MHz BW
Frequency Sense	Non-inverting

LO Characteristics

LO Frequency	13.05 GHz
Frequency Accuracy	± 0.01 ppm max over temp internal reference; ext. ref. input

Phase Noise @ F (Hz) >	100	1K	10K	100K	1M
dBC/Hz	-70	-80	-85	-100	-110

10 MHz level 3 dBm, ± 3 dB, 75 ohms, External In or Monitor out

Controls, Indicators

Ext 10 MHz	Yellow LED, indicates external 10 MHz reference selected (rear panel DPDT switch)
PLL Alarm	Red LED, External contact closure
Power	Green LED

Other

RF Connector	SMA (female), 50Ω
L-Band Connector	BNC (female), 50Ω
10 MHz connectors	BNC (female), 75Ω connector; Works for 50Ω/75Ω
Alarm Connector	DB9 - NO or NC contact closure on Alarm
Size	19 inch standard chassis 1.75" high X 14.0" deep
Power	100-240 ±10% VAC, 47 - 63 Hz, 25 watts max.

Available Connector Options

- M - 50Ω N-type (RF), 50Ω BNC (L-BAND)
- N - 50Ω N-type (RF), 75Ω BNC (L-BAND)
- NF - 50Ω N-type (RF), 75Ω F-type (L-BAND)
- NN - 50Ω N-type (RF), 50Ω N-type (L-BAND)
- S7 - 50Ω SMA (RF), 75Ω BNC (L-BAND)
- SF - 50Ω SMA (RF), 75Ω F-type (L-BAND)
- SN - 50Ω SMA (RF), 50Ω N-type (L-BAND)
- SS - 50Ω SMA (RF), 50Ω SMA (L-BAND)

*+10 to +40 degrees C; Specifications subject to change without notice