

**2083-1310 Block Translator, 1300-1700 to 950-1350 MHz**

**2083-1310 Block Translator** - The 2083-1310 Block Translator converts a 1300-1700 MHz block to 950-1350 MHz block with no spectrum inversion, low group delay and flat frequency response. The 1300-1700 MHz input is mixed with synthesized local oscillator (LO) signals, first to **3800 MHz** center frequency and finally to the **950-1350 MHz** block output. **The maximum input level (MAX IN) can be set for -20 to -40 dBm in 1±1 dB increments.** Multifunction switches select the **MAX IN** and internal or External (**Option E**) 10 MHz reference which appear on the LCD display and can be adjusted remotely. Front panel LEDs provide indication of DC power (green), PLL alarm (red), and remote operation (yellow). Connectors are **BNC female** for RF input and output. The unit is powered by a 100-240 ±10% VAC, 47-63 HZ input power supply and housed in a 1 3/4" X 19" X 16" rack mount chassis.

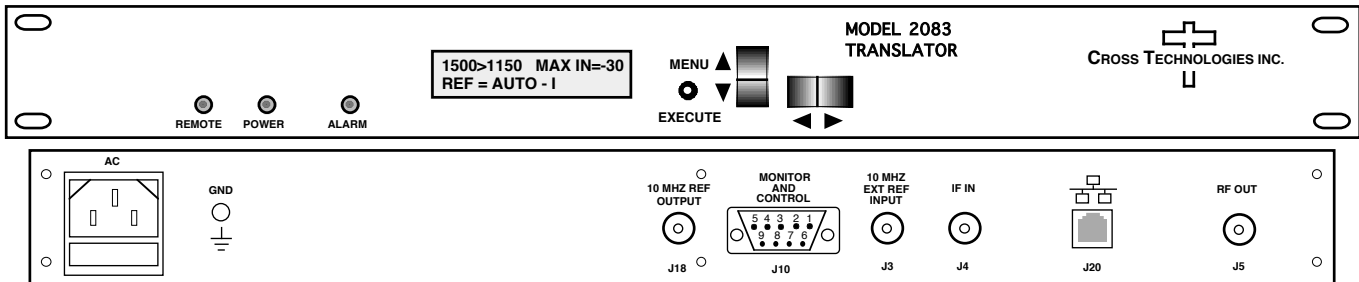

**2083-1310 Front and Rear Panels (Shown with optional Ethernet and option E)**

**EQUIPMENT SPECIFICATIONS\***

**Input Characteristics**

Input Impedance/RL **50Ω /12 dB**  
 Frequency **1300 - 1700 MHz**  
**Max Input Level setting -20 to -40 dBm, in 1±1dB steps**  
**Input Level Range 0 to -20 dB below MAX IN setting**  
**Noise Figure, max. 15 dB at -20 dBm MAX IN setting**

**Output Characteristics**

Impedance/RL **50Ω/12 dB**  
 Frequency **950 - 1350 MHz**  
 Output **Composite** Level **-20 to -60 dBm (MAX IN -20 to -40)**  
 Output 1 dB compression **-10 dBm, at max gain**

**Channel Characteristics**

Gain **0 ± 1 dB at Fc and MAX IN set to -20 dBm**  
 Frequency Response **± 1.5 dB, 400 MHz bandwidth; ± 0.5 dB, any 40 MHz increment**  
 Spurs-Inband (**NOTE 2**) **< -50 dBc in band, signal dependent and signal independent; -20 dBm out; (NOTE 1)**  
 Spurs-out of band(**NOTE 2**)**< -30 dBc, 0.5- 0.94 GHz and 1.36-2.1 GHz and 1.30-1.70 GHz feed through; -20 dBm out; (NOTE 1)**  
 Frequency Sense **Non-inverting**  
**Group Delay < 2ns, band; < 1 ns, any 65MHz**

**Synthesizer Characteristics**

Translation; Accuracy **1ppm; Option -H, ±0.01 ppm**  
 Reference **10 MHz Internal; Option -E, Internal/ External selection; external level 3±3 dBm**  
 Frequency Step **None, fixed frequency**

Phase Noise @ F (Hz) >	100	1K	10K	100K	1M
dBc/Hz	-70	-70	-80	-90	-100

**Controls, Indicators**

Fc Translation **Direct readout LCD; manual or remote selection**  
**MAX IN level** **Direct readout LCD; manual or remote selection**  
 Ext. ref. (Option -E) **Direct readout LCD; manual or remote selection**  
 Power; Alarm; Remote **Green LED; Red LED; Yellow LED**  
 Remote **RS232C, 9600 baud ; RS485, Ethernet Options**

**Other**

RF In/RF Out Connector **BNC (female)**  
 10 MHz Connector **BNC (female), 75Ω, works with 50 or 75 ohms**  
 Alarm/Remote Connector **DB9 (female) - NO or NC contact closure on Alarm**  
 Size **19 inch standard chassis 1.75" High X 16.0" Deep**  
 Power **100-240 (±10%) VAC, 47-63 Hz, 30 watts max.**

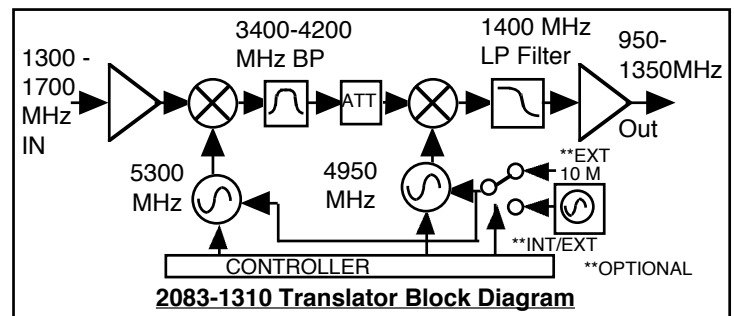

**NOTE 1:** dBc is relative to the COMPOSITE Output Level

**NOTE 2:** Spurs over MAX IN to MAX IN -20dB Range

**Available Options**

E - External 10 MHz Input & Output  
 H - High Stability (±0.01ppm) Internal Ref  
**Comm. Interface/Standard RS232**  
 Q - RS485 Remote Interface  
 W8 - Ethernet; w/Web Browser (WB)  
 W18 - Ethernet; w/WB & SNMP  
 W28 - Ethernet; w/TCP/IP, Telnet  
**W828 - Ethernet, W18 + W28**  
**Connectors/Impedance**  
 Std. - 50Ω BNC (RF IN), 50Ω BNC (RF OUT)  
 NN - 50Ω N (RF IN), 50Ω N (RF OUT)  
 SS - 50Ω SMA (RF IN), 50Ω SMA (RF OUT)  
**Contact Cross for other options**

\*+10 to +40 degrees C; Specifications subject to change without notice