

2083-0413 Block UHF to L Translator, Fixed Frequency

2083-0413 Block UHF to L Translator - The 2083-0413 Block UHF to L Translator converts a 220-400 MHz block to 1110-1290 MHz block with no spectrum inversion, low group delay and flat frequency response. The 220-400 MHz input is mixed with synthesized local oscillator (LO) signals, first to 2070 MHz center frequency and finally to the 1110-1290 MHz block output. Multi-function switches select the gain and internal or external 10 MHz. The input frequency band, output frequency band, internal or external reference, and gain (0 to +20 dB, selectable in 1 dB steps) settings appear on the LCD display. Front panel LEDs provide indication of DC power (green), PLL alarm (red), and remote operation (yellow). Remote operation allows setting the overall gain and 10 MHz reference. Connectors are BNC female for RF input and output and for the external 10 MHz reference (+3± 3 dBm in). It is powered by a 100-240 ±10% VAC, 47-63 HZ input power supply and in a 1 3/4" X 19" X 16" rack mount chassis.

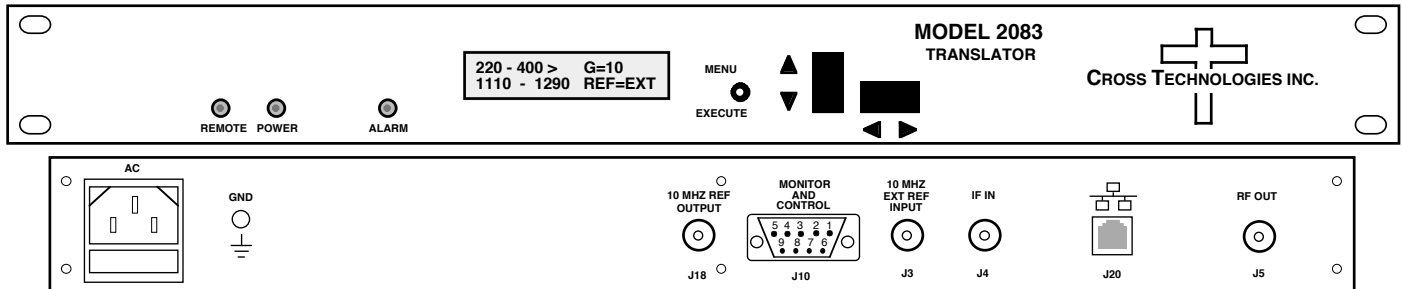

2083-0413 Front and Rear Panels (Shown with optional Ethernet)

EQUIPMENT SPECIFICATIONS*

Input Characteristics

Input Impedance/RL 50Ω/12 dB
 Frequency, 220 – 400 MHz
 Input Level -30 to -10 dBm
 Input, max. no damage +15 dBm

Output Characteristics

Impedance/RL 50Ω/12 dB
 Frequency 1110 – 1290 MHz
 Output Level, Range -30 to -10 dBm
 Output 1 dB compression 0 dBm

Channel Characteristics

Gain at F_C 0 to +20 ± 2 dB, selectable in 1 ± 1 dB steps
 Frequency Response ± 1.5dB, 180 MHz bandwidth; ± 0.5 dB, any 40 MHz increment
 Spurious, In band >45 dBC signal dependent or independent at -10 dBm out
 Spurious, Out of band <-50 dBm, 0.5 - 1.10 and 1.30 - 2.0 GHz
 Frequency Sense Non-inverting

Synthesizer Characteristics

Frequency Accuracy ± 1.0 ppm max over temp (±0.01 ppm, option-H)
 Reference 10 MHz Internal; Internal/External
 Frequency Step None, fixed frequency translation

Phase Noise @ F (Hz) >	100	1K	10K	100K	1M
dBC/Hz	-65	-70	-80	-95	-110

10 MHz Level (In or Out) 3 dBm, ± 3 dB, 75 ohms

Controls, Indicators

Gain Selection direct readout LCD; manual or remote selection
 Pwr; Alarm; Rem; Green LED; Red LED; Yellow LED
 Remote RS232C, 9600 baud (**RS485, Ethernet Optional**)

Other

RF In/RF Out Connector BNC (female), 50Ω
 10 MHz Conn. (In & Out) BNC (female), **75Ω, works with 50 or 75 ohms**
 Alarm/Remote Connector DB9 (female) - NO or NC contact closure on Alarm
 Size 19 inch standard chassis 1.75" high X 16.0" deep
 Power 100-240 (±10%) VAC, 47-63 Hz, 30 watts max.

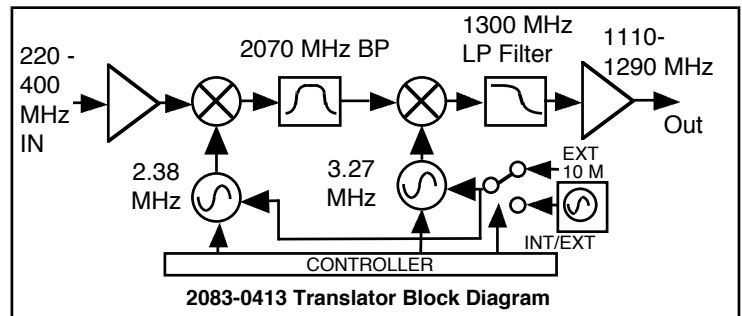

Available Options

H - High Stability (±0.01ppm) Internal Ref
Comm. Interface/Standard RS232
 Q - RS485 Remote Interface
 W8 - Ethernet; w/Web Browser (WB)
 W18 - Ethernet; w/WB & SNMP
 W28 - Ethernet; w/TCP/IP, Telnet
W828 - W8 +W18 +W28
Connectors/Impedance
 B - 75Ω BNC (RF), 75Ω BNC (IF)
 C - 50Ω BNC (RF), 75Ω BNC (IF)
Contact Cross for other options

*+10 to +40 degrees C; Specifications subject to change without notice