

2015-14 Upconverter, 950 - 2150 MHz, 140 MHz IF

The 2015-14 L-band Upconverter converts 140 ± 36 MHz to 950 to 2150 MHz in 1kHz, 10kHz, or 125kHz steps (user selectable) with low group delay and flat frequency response. Synthesized local oscillators (LO) provide very low phase noise and ±0.01 ppm stability frequency selection. Multi-function push button switches select the RF frequency, gain, and other parameters. Front panel LEDs provide indication of DC power (green), PLL alarm (red), remote operation (yellow) or the TX carrier is muted (yellow). Variable attenuators for the IF input and output provide a gain range of -10 to +30 dB as adjusted by the front panel multi-function push-button switches. Remote operation allows selection of frequency and gain. Parameter selection and frequency and gain settings appear on the LCD display. Connectors are BNC (female) for IF and the optional external reference input and output, and Type F (female) for the RF output. SSPB +24 VDC, 2.5 Amps and 10 MHz reference can be inserted on the RF line as added options. The 10 MHz option also includes a 10 MHz output connector, which contains either the internal or external 10 MHz reference signal. The unit is powered by a 100-240 ±10% VAC power supply, and housed in a 1 3/4" X 19" X 16" rack mount chassis.

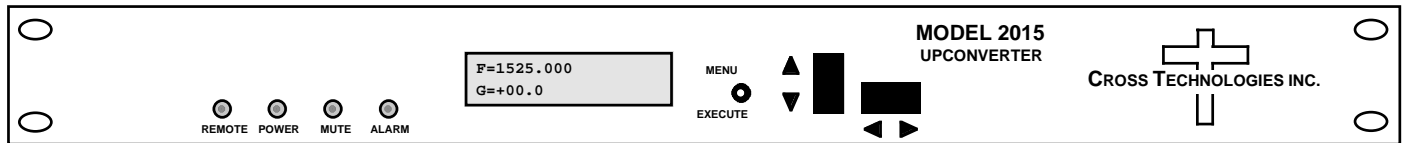

Front Panel

EQUIPMENT SPECIFICATIONS*

Input Characteristics (IF)

Impedance/Return Loss 75 Ω /18 dB
 Frequency 140 ± 36 MHz
 Input Level -40 to -10 dBm

Output Characteristics (RF)

Impedance/Return Loss 75 Ω/12 dB
 Frequency 950 to 2150 MHz
 Output level 0 to -20 dBm
 Output 1 dB comp. +5 dBm

Channel Characteristics

Gain range (adjustable) -10.0 to +30.0 dB
 Frequency Response ±1.5 dB, 950 - 2150 MHz ; ± 0.5 dB, 36 MHz BW
 Spurious Response < -50 dBc, in band
 Group Delay, max 0.01 ns/MHz² parabolic; 0.03 ns/MHz linear; 1 ns ripple
 Frequency Sense Non-inverting

Synthesizer Characteristics

Frequency Accuracy ± .01 ppm internal reference
 Frequency Step 1kHz, 10kHz, or 125kHz (user selectable)
 10 MHz In/Out Level 3 dBm ± 3 dB (option E)

Phase Noise @ Freq	100Hz	1kHz	10kHz	100kHz	1MHz
dBC/Hz	-75	-90	-97	-107	-117

Controls, Indicators

Freq/Gain Selection direct readout LCD; pushbutton switches or remote selection
 Pwr; Alarm; Rem; Mute Green LED; Red LED; Yellow LED; Yellow LED
 Remote RS232C, 9600 baud

Other

RF Connector Type F (female)
 IF Connector BNC (female)
 10 MHz Connectors BNC (female), 50Ω/75Ω (option E)
 Alarm/Remote Connector DB9 - NO or NC contact closure on Alarm
 Size 19 inch, 1RU standard chassis 1.75"high X 16.0" deep
 Power 100-240 ±10% VAC, 47-63 Hz, 45 watts max

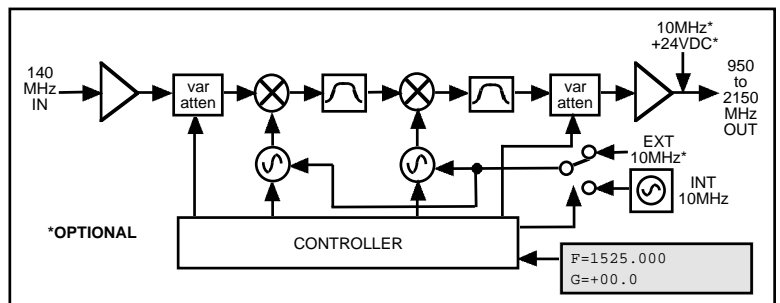

Block Diagram

Available Options

- E - External 10 MHz ref input & output w/ RF insertion
- V - SSPB Voltage, +24VDC, 2.5 amps
- Q - RS485 Remote Interface
- T - Temperature Sensor
- Z - Attenuator 0.1 dB on Upconverter Connectors/Impedance
- B - 75Ω BNC (RF), 75Ω BNC (IF)
- C - 50Ω BNC (RF), 75Ω BNC (IF)
- D - 50Ω BNC (RF), 50Ω BNC (IF)
- N - 50Ω N-type (RF), 75Ω BNC (IF)
- M - 50Ω N-type (RF), 50Ω BNC (IF)

*10°C to 40°C; Specifications subject to change without notice